



**ENGINEERING DATA**

**G71MPP**  
**DAVE LENNOX SIGNATURE® COLLECTION**  
**Multi-Position - Variable Capacity - Variable Speed Blower**

Bulletin No. 210507  
 March 2008  
 February 2008



**AFUE - 95.0%**  
**Input - 66,000 to 132,000 Btuh**  
**Nominal Add-on Cooling - 2 to 5 Tons**

**MODEL NUMBER IDENTIFICATION**

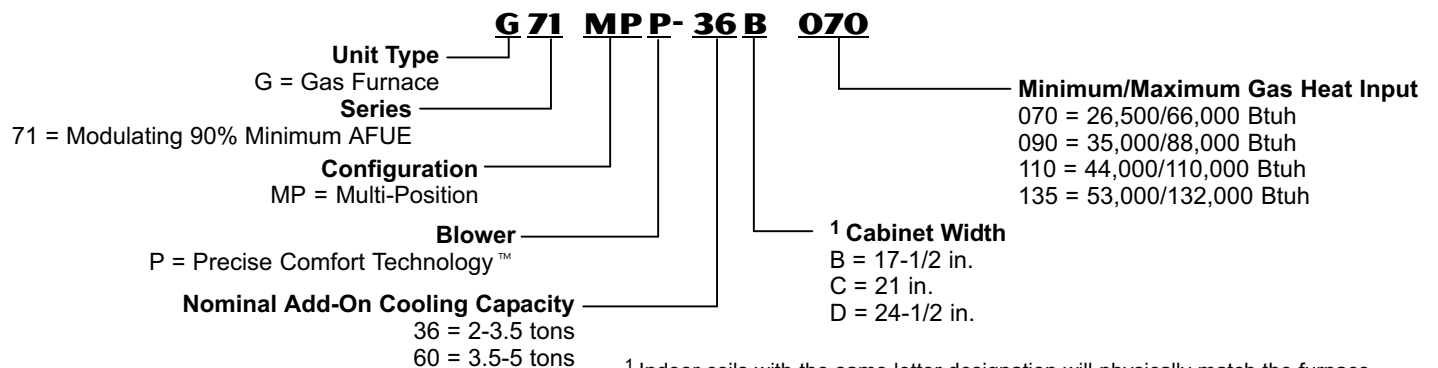

<sup>1</sup> Indoor coils with the same letter designation will physically match the furnace.

## FEATURES

### CONTENTS

Blower Data .....	Pages 16-26
Dimensions .....	Pages 10-15
Exhaust Pipe Venting Information .....	Page 8
Features and Options .....	Pages 2-6
Installation Clearances .....	Page 9
Model Number Identification .....	Page 1
Optional Accessories Selection Table .....	Page 7
Specifications .....	Page 6

### WARRANTY

Duralok Plus® Aluminized Steel **Heat Exchanger** - **Limited lifetime warranty** in residential applications (twenty year transferrable), ten years in non-residential applications.

**All Other Covered Components - Limited ten year warranty** in residential applications, one year in non-residential applications.

Refer to Lennox Equipment Limited Warranty certificate included with equipment for details.

### APPROVALS

Units certified by CSA International and ratings are certified by GAMA.

Units tested and rated according to US DOE test procedures and FTC labeling regulations.

Blower data from unit tests conducted in Lennox Laboratory air test chamber.

Approved by the California Energy Commission and meets California Nitrogen Oxides (NO<sub>x</sub>) Standards.

ENERGY STAR® certified units are designed to use less energy, help save money on utility bills, and help protect the environment.

ISO 9001 Registered Manufacturing Quality System.

### APPLICATIONS

Input capacities of 66,000, 88,000, 110,000, & 132,000 Btuh. Variable heat capacity in increments as low as 1% within minimum/maximum input range.

Energy efficiency (AFUE) 95% in all four installation configurations.

Compact cabinet for up-flow, down-flow, horizontal-left or horizontal-right applications without any internal modifications to the unit.

Variable speed blower ideal for zoning applications.

Lennox add-on indoor coils, high-efficiency air cleaners and humidifiers can easily be added to furnace.

Shipped factory assembled with controls installed and wired. Each unit factory test operated to ensure proper operation.

#### Zoning Applications

The G71MPP furnace is designed to work with the Lennox Harmony III™ zoning system. Zoning system provides direct feedback to the G71MPP, controlling both airflow and heat output to precisely match the comfort requirements for up to four zones.

### DIRECT VENT

Furnace can only be installed in Direct Vent (two pipe) applications. In Direct Vent applications, combustion air is supplied from outdoors and flue gases are discharged outdoors.

### OPTIONS

#### Termination Kits

Facilitates installation of combustion air intake pipe and flue exhaust pipe.

Refer to venting table in this bulletin to determine pipe size needed and proper termination kit required.

See Specifications table and dimension drawings.

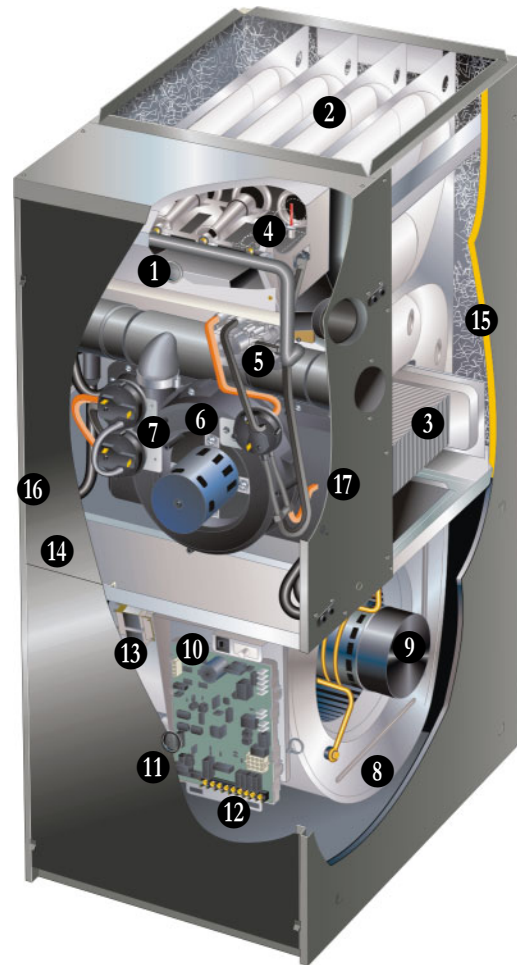

#### Termination Kit - Concentric

2 or 3 inch kit contains concentric termination assembly, reducer bushing and 45 degree elbow.

2 inch kit for -070 models contains an exhaust accelerator. Kit requires single hole penetration of roof or wall for installation.

Roof Termination Flashing Kit is available for use with 2 inch Kits.

CSA certified.

#### Termination Kits - Wall Assembly

##### Close Couple

2 or 3 inch kit consists of close-couple, side-by-side PVC piping with galvanized steel wall cover plate for sealing and isolating piping penetration of the wall.

Piping spacing and length is sized for proper wall installations. CSA certified.

##### Close Couple WTK

2 or 3 inch kit contains one insulated faceplate, one insulated exhaust pipe, elbow and fittings.

##### Wall Ring

2 inch kit contains 2 stainless steel outside seal caps, 2 galvanized steel inside seal caps, 4 seal rings for the caps and 18 inch insulation sleeve for sealing and isolating intake and exhaust piping penetration of wall.

Maintain a maximum of 6 inches between the inlet and outlet openings in the installation of the pipes.

#### Roof Termination Flashing Kit

2 or 3 inch kit contains two neoprene rubber roof flashings for vertical venting through a roof.

Vent pipe and insulation not furnished.

Also available for use with 2 inch (use 3 inch flashing)

Concentric Vent Termination Kits used in vertical venting rooftop applications.

## FEATURES

### HEATING SYSTEM

- 1 SilentComfort™ Technology**  
Patented burner sound enclosure and extra cabinet insulation reduces operating sound levels.
- 2 Lennox Duralok Plus® Heat Exchanger Assembly**  
Lennox developed heat exchanger assembly consists of primary heat exchanger and secondary condenser coil assembly.  
Main 3-pass crimped seam design clamshell type heat exchanger.  
Constructed of heavy-gauge, aluminized steel.  
Designed for normal expansion and contraction with maximum efficiency and minimum resistance to air flow.
- 3 Secondary heat exchanger condenser coil constructed of aluminum fins fitted to stainless steel tubes.**  
Coil is factory tested for leaks.  
Condensate drain header box assembly located on front of coil.  
Compact size of complete heat exchanger assembly permits low overall design of furnace cabinet.  
All components mounted in a heavy-gauge steel frame.  
Heat exchanger assembly has been laboratory life cycle tested.

#### Lennox Designed Header Box

Header box on end of condenser coil collects flue condensate for disposal through condensate collars. Hose connects the header box drains to the condensate collars.  
The condensate collars are located on each side of the cabinet for easy field installation of condensate drain trap. Only one collar is used, the remainder stay plugged.  
Condensate drain trap is included with the unit for field installation.

#### Lennox Designed Flue Condensate Trap Assembly

Condensate trap assembly is mounted outside the conditioned air stream.  
Assembly can be mounted on either side of cabinet in up-flow and down-flow applications. Assembly is mounted on the bottom of the cabinet in horizontal applications. See Installation Instructions.  
Connection can be made with field provided 1/2 in. PVC pipe, 3/4 in. PVC coupling, or 1-1/4 in. OD x 1 in. ID vinyl tubing with hose clamp.  
Optional Condensate Trap Alternate Location Kit allows condensate drain to be installed on the opposite side of the furnace from the exhaust venting (up-flow applications only).  
Easy to clean and winterize.

- 4 Inshot Burners**  
Aluminized steel inshot burners provide efficient, trouble-free operation.  
Burner venturi mixes air and gas in correct proportion for proper combustion.  
Burner assembly is removable from the unit as a single component for ease of service.
- 5 Variable Capacity Gas Control Valve**  
Variable capacity gas control valve adjusts capacity output in 1% increments. 24 volt redundant combination valve combines manual shut off valve (On-Off), automatic electric valve (dual) and gas pressure regulation into a compact combination control.

#### Flame Rollout Switch

Manual reset switches are factory installed on burner box. Switch provides protection from abnormal operating conditions.

#### SureLight® Hot Surface Ignitor

Tough, reliable, long-life, trouble-free performance. Tungsten heater element sandwiched between two plates of silicon nitride.  
Cemented to steatite block for protection against current leakage.  
Ignition leads constructed of nickel plated copper enclosed in high temperature Teflon insulation for dependable operation. No electrical noise.

- 6 Variable Speed Combustion Air Inducer**

Three-phase variable speed inducer motor is controlled by the SureLight® Integrated Variable Heating Capacity / Variable Speed Blower Control.  
Overload protected (auto-reset).  
Heavy-duty blower prepurges heat exchanger and safely vents flue products.

- 7 Pressure switches prove blower operation before allowing gas valve to open.**  
Operates only during heating cycle.

#### Limit Controls

Automatic reset, primary and secondary limits are accurately located.  
Primary limit factory installed on vestibule panel on all units, secondary limit factory installed on blower housing.

### OPTIONS

#### High Altitude Pressure Switch Kit

Required on certain units for proper unit operation on installations above 7,500 ft.

#### LPG/Propane Conversion Kit

Required for field changeover from natural gas to LPG/Propane. Includes gas valve and orifices.

#### Natural Gas Conversion Kit

Required for field changeover from LPG/Propane to natural gas.

### BLOWER

#### Variable Speed Direct Drive Blower

Each blower assembly statically and dynamically balanced.  
Change in blower speeds is easily accomplished by simple DIP switch changes on the SureLight® Integrated Variable Heating Capacity / Variable Speed Blower Control.  
See Blower Performance tables.  
Blower assembly easily removed for servicing.

- 8 Blower assembly easily removed for servicing.**
- 9 Variable Speed Blower Motor**

Variable speed motor maintains specified air volume from 0 though 0.80 in. w.g. static range.  
Variable speed operation is achieved by the use of an ECM (Electronically Commutated Motor) motor.  
Motor is controlled by the SureLight® Integrated Variable Heating Capacity / Variable Speed Blower Control.  
Motor is equipped with ball bearings and is resiliently mounted.  
When furnaces are used with Harmony Zone III™ Control System, blower motor operates from predetermined minimum - maximum air volumes to satisfy zone requirements.

## FEATURES

### CONTROLS

#### 10 SureLight® Integrated Variable Heating Capacity / Variable Speed Blower Control

Control board contains all necessary controls and relays to operate furnace.

Control is factory installed in the unit control box.

Innovative AirFlex™ technology allows custom blower settings based on the application.

Precise Comfort Technology™ automatically adjusts blower speed and heat input in increments as low as 1% for greater temperature control.

Designed to operate in a variable rate capacity mode using a two-stage thermostat. The unit will automatically adjust firing rate based on thermostat cycle times. For optimal performance, the use of a high-quality, digital thermostat with adjustable settings for first stage/second stage, on/off differentials and adjustable stage timers is recommended.

Provides variable capacity furnace input control with a conventional two-stage thermostat in increments as small as 1%. Furnace can also operate as a conventional two-stage unit with inputs of 70% and 100%.

Provides three-stage furnace input control (40%, 70%, 100%) with a conventional single-stage thermostat.

Variable-speed combustion air inducer is controlled by board. Prior to ignition, a pre-purge cycle for 15 seconds is initiated. After the main burners are turned off, a post-purge cycle for 20 seconds is run.

**Ignition Control** - Ignition control board continuously monitors line voltage and maintains the igniter power at a constant level to provide consistent lighting and maximum igniter life.

**Safety Controls** - Electronic flame sensor assures safe, reliable operation.

Should flame fail to ignite, flame sensor will initiate 4 re-attempts at ignition before locking out unit operation for 60 minutes.

Watchguard type circuit automatically resets ignition controls after one hour of continuous thermostat demand after unit lockout, eliminating nuisance calls for service.

#### 11 Display LED

- Seven segment LED displays alpha-numeric information related to diagnostics as well as system operation and status. Diagnostic codes are held in non-volatile memory, immune from power interruptions. Holds up to ten diagnostic codes in order of occurrence for recall on demand. Port on blower door allows for easy viewing.

#### DIP Switch Settings

Select Thermostat used - Single Stage or Two-Stage.

Select Operation Mode - Two-Stage, Three-Stage or Variable Capacity.

Two selectable second stage recognition times (7 and 12 minutes) are available on the board when the furnace is used with a single-stage thermostat. When used with a two-stage thermostat, furnace will only initiate second stage operation with a second stage thermostat demand.

**Heating Speeds** - A combination of DIP switch settings allow Normal, 7.5% increase, 15% increase, 7.5% decrease or 15% decrease motor speed selection within heating speed selected for fine tuning air volume. See Blower Performance tables.

**Cooling Speeds** - A combination of DIP switch settings allow Normal, 10% increase or 10% decrease motor speed selection within cooling speed selected for fine tuning air volume. See Blower Performance tables.

**Blower Speed Ramping (Cooling Mode)** - DIP switch settings allow one of four blower speed profiles during cooling operation.

**Profile A (factory setting)** - Motor runs at 50% for 30 seconds, then at 82% for 7-1/2 minutes, then at 100% (if needed) until demand is satisfied. Once demand is met, motor runs at 50% for 30 seconds, then ramps down to stop.

**Profile B** - Motor runs at 82% for 7-1/2 minutes and then at 100% (if needed) until demand is satisfied. Once demand is met, motor ramps down to stop.

**Profile C** - Motor runs at 100% until demand is satisfied. Once demand is met, motor runs at 100% for 60 seconds, then ramps down to stop.

**Profile D** - Motor runs at 100% until demand is satisfied. Once demand is met, motor ramps down to stop.

**Dehumidification (Active or Humiditrol® Option)** - A jumper on the control board must be clipped to enable active dehumidification and/or operation with a Humiditrol Whole-Home Dehumidification System. A humidity controlling thermostat or device is also required. During a call for cooling, air volume is automatically reduced, forcing humidity removal by the air conditioner or heat pump system. After the humidity has reached the desired set-point the cooling air volume returns to its designed rate. A dehumidification signal from the thermostat reduces the cooling cfm to 70% of the requested cooling cfm.

**Dual Fuel Operation** - A jumper on the control board must be clipped to enable operation with a single or two-stage heat pump. The indoor blower is started without delay when a call for heat is received.

**Two-Stage Cooling Operation** - A jumper on the control board must be clipped to enable operation with a two-stage air conditioner. The cooling blower speeds for first and second stage cooling will be dictated by the applicable DIP switch settings.

**Blower On Time (Heating)** - Blower on time is fixed at 45 seconds, blower off time is adjustable from 60, 90, 120 and 180 seconds (factory setting - 90 seconds).

**Blower Off Time (Cooling)** - For air-conditioning applications, blower on time is 2 seconds following thermostat demand for cooling.

Blower off delay is 30 seconds at 50% of high cool cfm. Board controls evaporator humidity by controlling blower and compressor speed on two stage outdoor units when used with Lennox ComfortSense™ thermostat.

**Continuous Blower Speed** - Adjustable continuous blower speed is a percentage of the high cooling speed selection. There are four selectable options (via DIP switch settings) of 28%, 38% (default setting), 70% and 100%.

#### 12 Accessory Terminals

- Two accessory terminals furnished for additional power supply requirements for 120 volt (less than 1 amp) power humidifiers and powered air cleaners.

One 24 volt humidifier output furnished for non-powered humidifiers.

#### 13 24 Volt Transformer

Furnished and factory installed in control box. 40VA transformer has circuit breaker wired in series.

#### 14 Field Wiring Make-up Box

Furnished for line voltage wiring. Factory installed internally on left side of furnace. Box may be installed internally or externally on either side of furnace.

## FEATURES

### CONTROLS - CONTINUED

#### OPTIONS

##### ComfortSense™ 7000 Touchscreen Thermostat (Recommended Thermostat for G71MPP Furnaces)

Electronic 7-day, universal, multi-stage, programmable, touchscreen thermostat.

4 Heat/2 Cool.

Auto-changeover.

Controls humidity during cooling mode.

Offers enhanced capabilities including humidification / dehumidification / dewpoint measurement and control, Humiditrol® control, and equipment maintenance reminders.

Easy-to-use, menu driven thermostat with a back-lit, LCD touchscreen.

Remote outdoor temperature sensor (optional) allows the thermostat to display outdoor temperature. Required in dual fuel and Humiditrol® applications.

See the ComfortSense™ 7000 Engineering Handbook bulletin in the Controls section for more information.



#### Thermostat

Lennox recommends the use of a high-quality, digital thermostat with adjustable settings for first stage/second stage on/off differentials (adjusted to lowest setting) and adjustable up-stage timers (turned off or adjusted to maximum setting. Minimum time - one hour).

See Thermostat bulletins in Controls section and Lennox Price Book for a complete list of thermostats.

#### CABINET

Low-profile, narrow width cabinet allows easy installation in up-flow, down-flow or horizontal applications.

Heavy-gauge, cold rolled steel construction.

Pre-painted cabinet finish.

Flanges provided on supply air opening for ease of plenum connection or alignment with indoor coil.

- 15 Fully insulated cabinet with foil faced insulation on sides and back of heating compartment and mat faced insulation in blower compartment.

Complete service access.

- 16 Tool-less latches on blower and burner doors assure positive lock.

Safety interlock switch automatically shuts off power to unit when blower compartment access door is removed.

- 17 Gas piping and electrical inlets are provided in both sides of cabinet.

#### Return Air Entry:

For bottom/end return-air entry for up-flow/horizontal applications, remove furnished bottom seal panel from cabinet.

For side return-air entry (up-flow applications only), corners are marked on either side of cabinet for return air cut-outs.

On furnaces with side return air and condensate trap on the same side of the cabinet, a field fabricated transition or RAB is required when using an IAQ product higher than 14-3/16 in. installed next to the unit and serviced from the front. IAQ products higher than 20 in. require a field fabricated transition. See dimension drawings.

**NOTE - 60C and 60D size units that require air volumes over 1800 cfm must have one of the following:**

1. Single side return air with transition, to accommodate 20 x 25 x 1 in. cleanable air filter, required to maintain proper air velocity.
2. Single side return air with optional RAB Return Air Base.
3. Bottom return air.
4. Return air from both sides.
5. Bottom and one side return air.

See Blower Performance Tables for additional information.

#### Coil Match-up

All furnaces exactly match C33 and CX34 cased up-flow indoor coils and CH33 horizontal indoor coils with same letter designation in model number. No adaptor required. Engaging holes furnished on cabinet for alignment.

C33 uncased coils match furnaces without any overhang but require an optional adaptor base or field fabricated transition to match furnace opening. See C33 coil bulletin for additional information.

All furnaces exactly match CR33 cased, down-flow indoor coils with adaptor rails, furnished with coil.

#### OPTIONS

##### Condensate Drain Heat Cable Kits

Self-limiting wattage heat cable prevents condensate drain from freezing in unconditioned areas.

Available in 6, 24 or 50 ft. lengths.

Heat Cable Tape:

66 ft. length, 1/2 in. wide fiberglass.

60 ft. length, 2 in. wide aluminum foil.

##### Condensate Trap Alternate Location Kit

Allows condensate drain to be installed on the opposite side of the furnace from the exhaust venting (up-flow applications only).

##### Down-Flow Additive Base

Required for heating only units installed on combustible floors.

Not required in add-on cooling applications.

See Dimension Drawing.

##### Horizontal Support Frame Kit

Provides support of unit in horizontal applications.

Consists of (2) 1 x 1-1/2 x 32-5/8 in. and (2) 1 x 3 x 53-7/8 in. painted, heavy-gauge cold rolled steel support channels with assembly and suspending holes. Bolts and nuts furnished for field assembly. Suspending rods must be field provided.

##### RAB Return Air Base

On furnaces with side return air and condensate trap on the same side of the cabinet, a field fabricated transition or RAB is required when using an IAQ product higher than 14-3/16 in. installed next to the unit and serviced from the front. IAQ products higher than 20 in. require a field fabricated transition.

Must be used for 60C and 60D models with air volumes over 1800 cfm in up-flow applications when only one side return is required.

Cabinet is pre-painted steel to match the furnace.

See Dimension Drawing.

## FEATURES

### INDOOR AIR QUALITY

See Indoor Air Quality section and Lennox Price Book for a complete list of indoor air quality products (air purification systems, high efficiency air filters and filter cabinets, UV lights, humidifiers, fresh air ventilation system and heat/energy recovery systems).

### FILTER (NOT FURNISHED)

Filter and provisions for external mounting must be field provided.

### OPTIONS

#### Air Filter and Rack Kit for Horizontal Return Air (End) Applications

Washable or vacuum cleanable 1 inch polyurethane frame type filter and external end return air rack available for field installation.

Rack has filter door for easy filter servicing.

Flanges on rack allow easy duct connection.

See dimension drawing.

#### Air Filter and Rack Kit for Side Return Air Applications (Not for use with RAB Return Air Base)

Washable or vacuum cleanable 1 inch polyurethane frame type filter and external side return air rack available for field installation.

Available in single and ten pack kits.

Rack has filter door for easy filter servicing.

Flanges on rack allow easy duct connection.

Field installs on either side of unit cabinet.

See dimension drawing.

#### EZ Filter Base for Bottom Return Air Applications

Hinged door with thumbscrew for easy filter access.

Uses standard size filters (field provided).

## SPECIFICATIONS

Gas Heating Performance		Model No.	G71MPP -36B-070	G71MPP -36C-090	G71MPP -60C-090	G71MPP -60C-110	G71MPP -60D-135
<b>Maximum</b>	Input - Btuh		66,000	88,000	88,000	110,000	132,000
	Output - Btuh		60,000	81,000	81,000	103,000	123,000
	Temperature rise range - °F		50 - 80	60 - 90	50 - 80	50 - 80	55 - 85
	Gas Manifold Pressure (in. w.g.) Natural Gas / LPG/Propane		3.5 / 10.0	3.5 / 10.0	3.5 / 10.0	3.5 / 10.0	3.5 / 10.0
<b>Minimum</b>	Input - Btuh		26,000	35,000	35,000	44,000	53,000
	Output - Btuh		25,000	34,000	34,000	42,000	51,000
	Temperature rise range - °F		40 - 70	40 - 70	40 - 70	40 - 70	40 - 70
	Gas Manifold Pressure (in. w.g.) Natural Gas / LPG/Propane		0.7 / 2.0	0.7 / 2.0	0.7 / 2.0	0.7 / 2.0	0.7 / 2.0
	<sup>1</sup> AFUE		95.0%	95.0%	95.0%	95.0%	95.0%
	High static (CSA) - in. w.g.		.80	.80	.80	.80	.80
<b>Connections in.</b>	Intake / Exhaust Pipe (PVC)		2 / 2	2 / 2	2 / 2	2 / 2	3 / 3
	Condensate Drain Trap (PVC pipe) - i.d.		1/2	1/2	1/2	1/2	1/2
	with field supplied (PVC coupling) - o.d.		3/4	3/4	3/4	3/4	3/4
	hose with hose clamp - i.d. x o.d.		1 x 1-1/4	1 x 1-1/4	1 x 1-1/4	1 x 1-1/4	1 x 1-1/4
	Gas pipe size IPS		1/2	1/2	1/2	1/2	1/2
<b>Indoor Blower</b>	Wheel nominal diameter x width - in.		10 x 8	10 x 10	11-1/2 x 10	11-1/2 x 10	11-1/2 x 10
	Motor output - hp		1/2	1/2	1	1	1
	Tons of add-on cooling		2 - 3.5	2 - 3.5	3.5 - 5	3.5 - 5	3.5 - 5
	Air volume range - cfm		250 - 1395	250 - 1395	450 - 2215	450 - 2210	450 - 2190
<b>Shipping Data</b>	lbs. - 1 package		149	160	171	184	206
<b>Electrical characteristics</b>			120 volts - 60 hertz - 1 phase (less than 12 amps)				

NOTE - Filters and provisions for mounting are not furnished and must be field provided.

<sup>1</sup> Annual Fuel Utilization Efficiency based on DOE test procedures and according to FTC labeling regulations. Isolated combustion system rating for non-weatherized furnaces.

**OPTIONAL ACCESSORIES - MUST BE ORDERED EXTRA**

			"B" Width Models	"C" Width Models	"D" Width Models
<b>FILTER KITS</b>					
<sup>1</sup> Air Filter and Rack Kit	Horizontal (end)	Size of filter - in.	87L96 - 18 x 25 x 1	87L97 - 20 x 25 x 1	87L98 - 25 x 25 x 1
	Side Return	Single	44J22	44J22	44J22
		Ten Pack	66K63	66K63	66K63
		Size of filter - in.	16 x 25 x 1	16 x 25 x 1	16 x 25 x 1
EZ Filter Base	Catalog No. - Ship. Wt. - lbs.	73P56 - 7	73P57 - 8	73P58 - 10	
	Size of field provided filter - in.	16 x 25 x 1	20 x 25 x 1	24 x 24 x 1	

<b>CABINET ACCESSORIES</b>					
Down-Flow Additive Base			11M60	11M61	11M62
Horizontal Support Frame Kit			56J18	56J18	56J18
Return Air Base			98M60	98M58	98M59

<b>CONDENSATE DRAIN KITS</b>					
Condensate Drain Heat Cable		6 ft.	26K68	26K68	26K68
		24 ft.	26K69	26K69	26K69
		50 ft.	26K70	26K70	26K70
Heat Cable Tape	Fiberglass - 1/2 in. x 66 ft.		36G53	36G53	36G53
	Aluminum foil - 2 in. x 60 ft.		16P89	16P89	16P89
Condensate Trap Alternate Location Kit - Up-Flow Only			76M20	76M20	76M20

<b>CONTROLS</b>					
ComfortSense™ 7000 Thermostat			Y0349	Y0349	Y0349
Remote Outdoor Temperature Sensor (for dual fuel and Humiditrol)			X2658	X2658	X2658

<b>TERMINATION KITS</b> - See Installation Instructions for specific venting information.						
Termination Kits	Concentric	2 in.	71M80	69M29	---	
		3 in.	---	60L46	60L46	
	Wall - Close Couple	2 in.	22G44	---	---	
		3 in.	44J40	44J40	44J40	
	Close Couple WTK	2 in.	30G28	---	---	
		3 in.	81J20	81J20	81J20	
	Wall - Wall Ring Kit	2 in.	15F74	15F74	---	
	Roof	2 in.	15F75	15F75	---	
	Roof Termination Flashing Kit - Contains two flashings.			44J41	44J41	44J41

<sup>1</sup> Cleanable polyurethane frame type filter.

<b>GAS HEAT ACCESSORIES</b>			
Input	High Altitude Pressure Switch Kit	LPG/Propane Kit	LPG/Propane to Natural Gas Kit
	7501-10,000 ft.	0-10,000 ft.	0-10,000 ft.
-070	36W77	33W41	33W42
-090	40W05	33W41	33W42
-110	40W06	33W41	33W42
-135	40W07	33W41	33W42

## EXHAUST PIPE VENTING TABLE

Vent Pipe Diameter	<sup>1</sup> Maximum Equivalent Vent Length - ft.							
	For Altitudes of 0 - 4500 feet				For Altitudes of 4501 - 10,000 feet			
	G71MPP -36B-070	G71MPP -36C-090 -60C-090	<sup>2</sup> G71MPP -60C-110	<sup>3</sup> G71MPP -60D-135	G71MPP -36B-070	G71MPP -36C-090 -60C-090	<sup>2</sup> G71MPP -60C-110	<sup>3</sup> G71MPP -60D-135
2 in.	75	50	20	not allowed	60	25	not allowed	not allowed
2-1/2 in.	135	100	60	not allowed	125	60	40	not allowed
3 in.	150	125	125	125	150	125	90	70
4 in.	225	225	200	180	250	225	200	180

NOTE - Minimum Equivalent Vent Pipe length is 15 feet.

<sup>1</sup> Maximum Equivalent Vent Length<sup>1</sup> permitted is defined as "Total Length (linear feet) of vent pipe, plus equivalent length (ft.) of fittings, plus equivalent length (ft.) of termination.

<sup>2</sup> 110 models installed in up-flow or down-flow applications must have the supplied 90° street ell installed directly into the unit flue collar. The street ell must be included in the elbow count.

<sup>3</sup> 135 models installed in up-flow or down-flow applications must have 3 in. to 2 in. reducing elbow (supplied) installed directly into the flue collar. Reducing ell must be included in elbow count.

VENTING NOTES — One 90° elbow is equivalent to 5 feet of straight vent pipe.

Two 45° elbows are equal to one 90° elbow.

One 45° elbow is equivalent to 2.5 feet of straight vent pipe.

Wall and roof termination (non-concentric) exhaust pipe must terminate with reducer to improve exhaust velocity away from intake piping.

070 - 2, 2-1/2, 3 or 4 in. - terminate with 1-1/2 in. pipe

090 - 2, 2-1/2, 3 or 4 in. - terminate with 2 in. pipe

110 - 2-1/2, 3 or 4 in. - terminate with 2 in. pipe

135 - 3 or 4 in. - terminate with 2 in. pipe

## TERMINATION KITS - EQUIVALENT VENT LENGTHS

Heat Size	Vent Pipe Diameter in.	Vent Pipe Equivalent Length - ft.							
		Concentric Kits			Close Couple Kits		Wall Ring Kit	Outdoor Exhaust Accelerator (Diameter X Length)	
		2 in.		3 in.	2 in.	3 in.	2 in.	1-1/2 x 12 in.	2 x 12 in.
	<sup>3</sup> 71M80	69M29	60L46	22G44 30G28 (WTK)	44J40 81J20 (WTK)	15F74	---	---	
-070	2	12	---	not allowed	4	<sup>1</sup> 4	4	4	not allowed
	2-1/2	15	---	not allowed	5	<sup>1</sup> 5	5	5	not allowed
	3	24	---	not allowed	8	<sup>1</sup> 8	8	8	not allowed
	4	42	---	not allowed	14	<sup>1</sup> 14	14	14	not allowed
-090	2	---	3	3	not allowed	1	<sup>2</sup> 1	not allowed	1
	2-1/2	---	6	6	not allowed	2	<sup>2</sup> 2	not allowed	2
	3	---	6	6	not allowed	2	<sup>2</sup> 2	not allowed	2
	4	---	12	12	not allowed	4	<sup>2</sup> 4	not allowed	4
-110	2	---	3	3	not allowed	1	<sup>2</sup> 1	not allowed	1
	2-1/2	---	6	6	not allowed	2	2	not allowed	2
	3	---	6	6	not allowed	2	2	not allowed	2
	4	---	12	12	not allowed	4	4	not allowed	4
-135	3	---	not allowed	15	not allowed	6	6	not allowed	6
	4	---	not allowed	25	not allowed	10	10	not allowed	10

<sup>1</sup> Requires field provided 1-1/2 in. outdoor exhaust accelerator.

<sup>2</sup> Requires field provided 2 in. outdoor exhaust accelerator.

<sup>3</sup> Outdoor exhaust accelerator is included with 71M80 kit and is required with -070 model.

## INSTALLATION CONFIGURATIONS

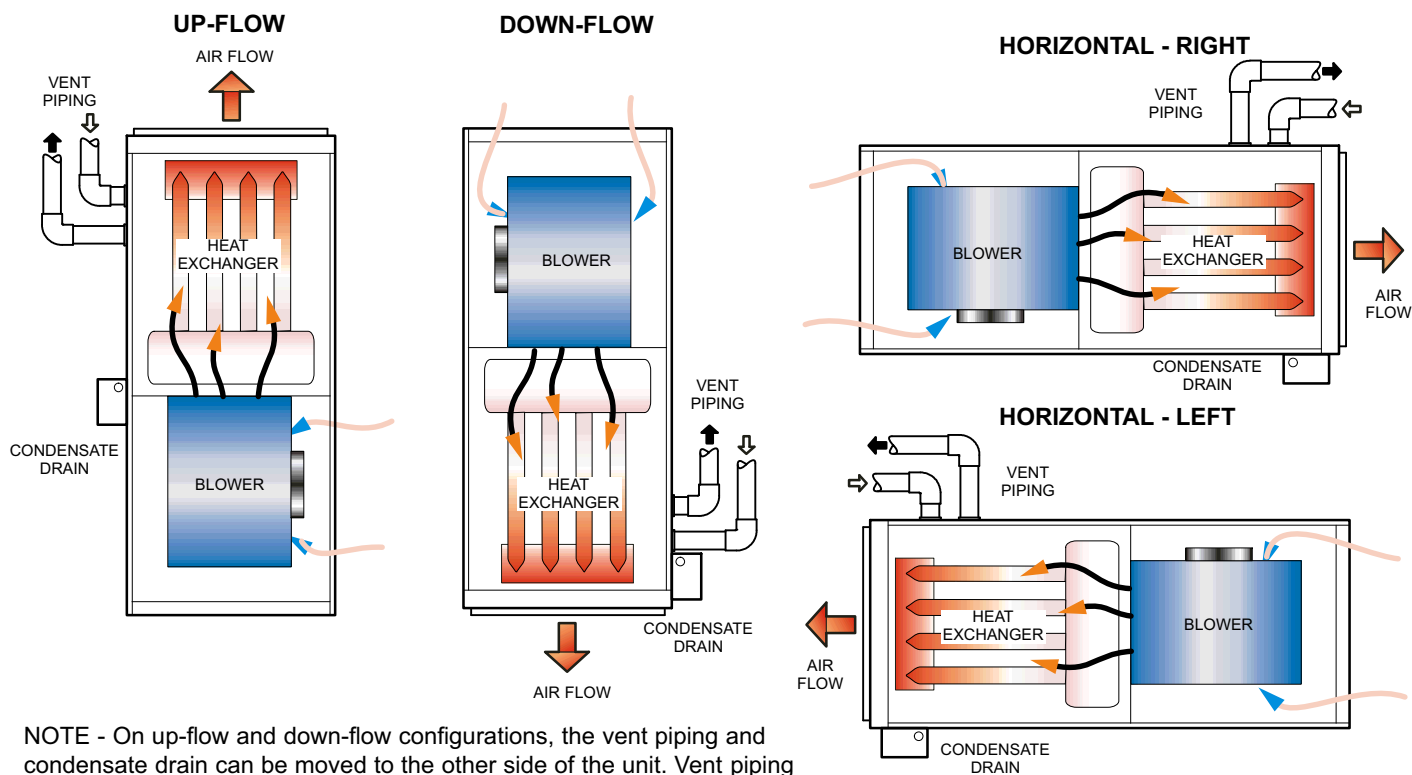

NOTE - On up-flow and down-flow configurations, the vent piping and condensate drain can be moved to the other side of the unit. Vent piping and drain must be installed on the same side of the unit with each other unless optional Condensate Trap Alternate Location Kit (up-flow only) is used. On horizontal installations the drain must be located at the bottom and the vent piping at the top.

### INSTALLATION CLEARANCES

Sides	1 0 inches (0 mm)
Rear	0 inches (0 mm)
Top/Plenum	1 inch (25 mm)
Front	0 inches (0 mm)
Front (service/alcove)	24 inches (610 mm)
Floor	2 Combustible

NOTE - Air for combustion and supply air ventilation must conform to the methods outlined in American National Standard (ANSI-Z223.1) National Fuel Gas Code or National Standard of Canada CAN/CGA-149.1, & CAN/CGA-149.2 "Installation Code for Gas Burning Appliances".

NOTE-In the U.S. flue sizing must conform to the methods outlined in current GAMA/A.G.A. venting tables, American National Standard (ANSI-Z223.1) National Fuel Gas Code or applicable provisions of local building codes. In Canada flue sizing must conform to the methods outlined in National Standard of Canada CAN/CGA-149.1 and .2.

<sup>1</sup> Allow proper clearances to accommodate condensate trap and vent pipe installation.

<sup>2</sup> Do not install the furnace directly on carpeting, tile, or other combustible materials other than wood flooring.

## DIMENSIONS - INCHES (MM) UP-FLOW POSITION SHOWN

**<sup>1</sup> NOTE - 60C and 60D size units that require air volumes over 1800 cfm (850 L/s) must have one of the following:**

- a. Single side return air with transition, to accommodate 20 x 25 x 1 in. (508 x 635 x 25 mm) air filter. Required to maintain proper air velocity.
- b. Single side return air with optional RAB Return Air Base
- c. Bottom return air.
- d. Return air from both sides.
- e. Bottom and one side return air.

**See Blower Performance Tables for additional information.**

<sup>2</sup> Optional External Side Return Air Filter Kit (Up-Flow Only) is not for use with the optional RAB Return Air Base.

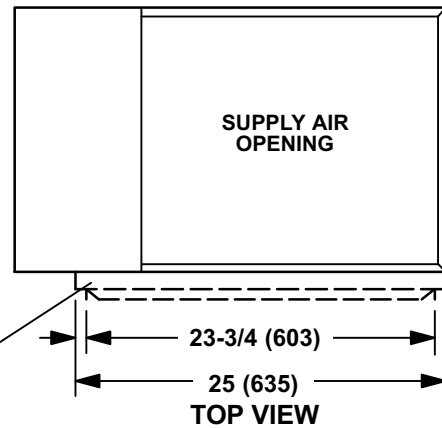

<sup>2</sup> OPTIONAL EXTERNAL SIDE RETURN AIR FILTER KIT (Either Side)

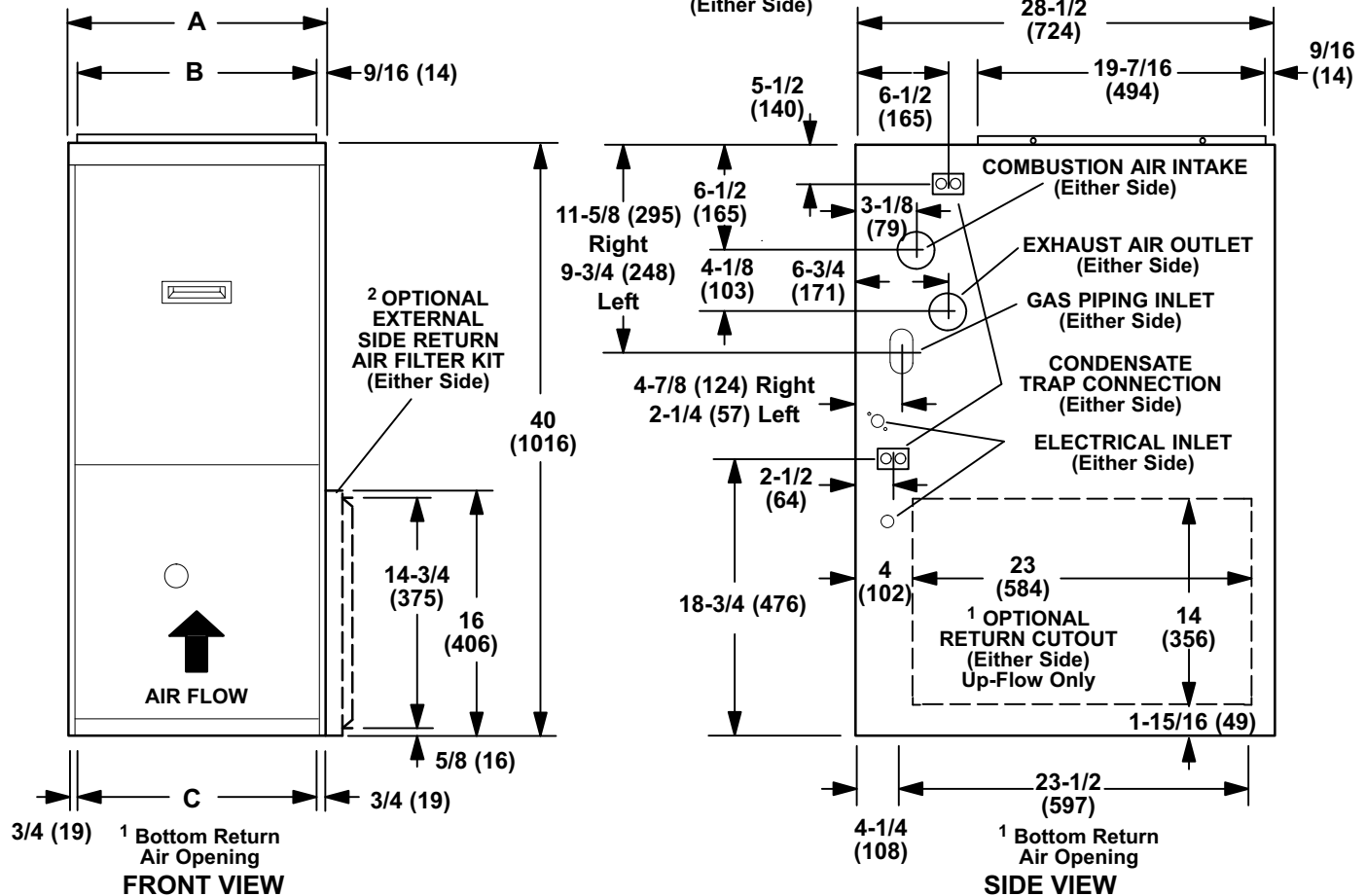

Model No.	A		B		C	
	in.	mm	in.	mm	in.	mm
G71MPP-36B-070	17-1/2	446	16-3/8	416	16	406
G71MPP-36C-090	21	533	19-7/8	454	19-1/2	495
G71MPP-60C-090						
G71MPP-60C-110						
G71MPP-60D-135	24-1/2	622	23-3/8	546	23	584

# DIMENSIONS - INCHES (MM) - FURNACE/COIL COMBINED DIMENSIONS

## UP-FLOW POSITION

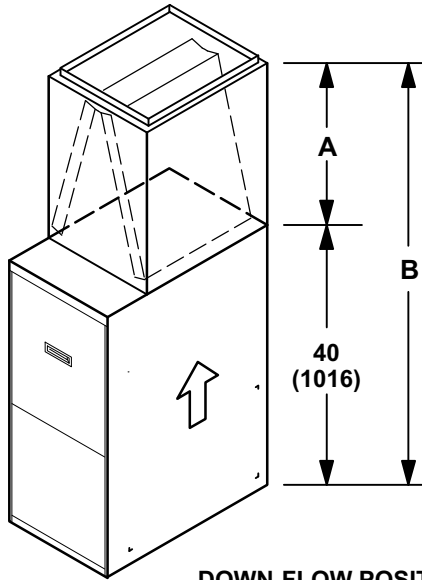

## DOWN-FLOW POSITION

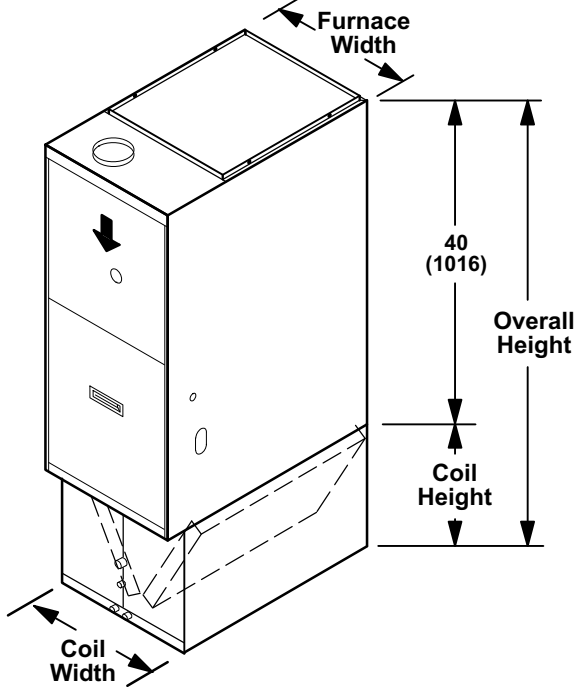

## HORIZONTAL

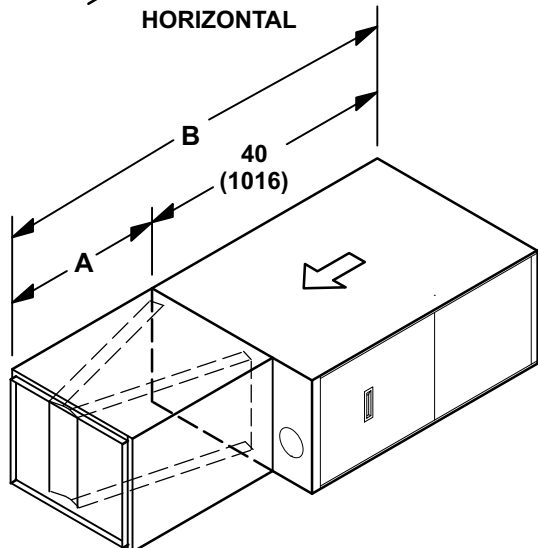

## UP-FLOW POSITION

Model No	Cased				Uncased (CX34 - cased only)			
	A		B		A		B	
	in.	mm	in.	mm	in.	mm	in.	mm
CX34-18/24B-6F C33-24B CX34-18/24C-6F C33-24C	16-1/2	419	56-1/2	1435	13-7/8	352	53-7/8	1368
CX34-25B-6F C33-25B	19-1/2	495	59-1/2	1511	15-7/8	403	55-7/8	1419
CX34-30B-6F C33-30B CX34-30C-6F C33-30C	20-1/2	521	60-1/2	1537	17-3/4	451	59-3/4	1467
CX34-31B-6F C33-31B	23-1/2	597	63-1/2	1613	20-1/4	514	60-1/4	1530
CX34-36B-6F C33-36B	24-1/2	622	64-1/2	1638	21-7/8	556	61-7/8	1572
CX34-36C-6F C33-36C	24-1/2	622	64-1/2	1638	21-1/4	540	61-1/4	1556
CX34-38B-6F C33-38B	24-1/2	622	64-1/2	1638	22	559	62	1575
CX34-42B-6F C33-42B	24-1/2	622	64-1/2	1638	21-7/8	556	61-7/8	1572
CX34-43B-6F C33-43B	28-1/2	724	68-1/2	1740	26-1/4	667	66-1/4	1683
CX34-43C-6F C33-43C	28-1/2	724	68-1/2	1740	25-3/4	654	65-3/4	1670
C33-44C	24-1/2	622	64-1/2	1638	21-1/2	546	61-1/2	1562
CX34-44/48B-6F C33-48B	24-1/2	622	64-1/2	1638	22-1/8	562	62-1/8	1578
CX34-44/48C-6F C33-48C	24-1/2	622	64-1/2	1638	21-1/2	546	61-1/2	1562
CX34-49C-6F C33-49C	29-1/2	749	70-1/2	1791	28-1/2	724	68-1/2	1740
CX34-50/60C-6F C33-50/60C	27-1/2	699	67-1/2	1715	24-3/4	629	64-3/4	1645
CX34-60D-6F C33-60D	25-1/2	648	65-1/2	1664	24-3/4	629	64-3/4	1645
CX34-62C-6F C33-62C	32-1/2	826	72-1/2	1842	30-5/8	778	70-5/8	1793
CX34-62D-6F C33-62D	29-1/2	749	69-1/2	1765	28-3/4	730	68-3/4	1746

## DOWN-FLOW POSITION

Model Number	Coil Width		Furnace Width		Coil Height		Overall Height	
	in.	mm	in.	mm	in.	mm	in.	mm
CR33-24B-F	17-1/2	446	17-1/2	446	13-1/4	337	53-1/4	1353
CR33-30/36B-F	17-1/2	446	17-1/2	446	16-1/8	410	56-1/8	1426
CR33-30/36C-F	21	533	21	533	16-1/8	410	56-1/8	1426
CR33-48B-F	21	533	17-1/2	446	20	508	60	1524
CR33-48C-F	21	533	21	533	20	508	60	1524
CR33-50/60C-F	24-1/2	622	21	533	23-5/8	600	53-5/8	1362
CR33-60D-F	24-1/2	622	24-1/2	622	23-5/8	600	53-5/8	1362

## HORIZONTAL POSITION

Model Number	A		B	
	in.	mm	in.	mm
CH33-36B-2F CH33-36C-2F CH33-42B-2F CH33-48C-2F CH33-60D-2F	26-1/2	673	66-1/2	1689
CH33-44/48B-2F CH33-50/60C-2F	31-1/2	800	71-1/2	1816
CH33-62D-2F				



# OPTIONAL ACCESSORY DIMENSIONS - INCHES (MM)

## HORIZONTAL FILTER KIT

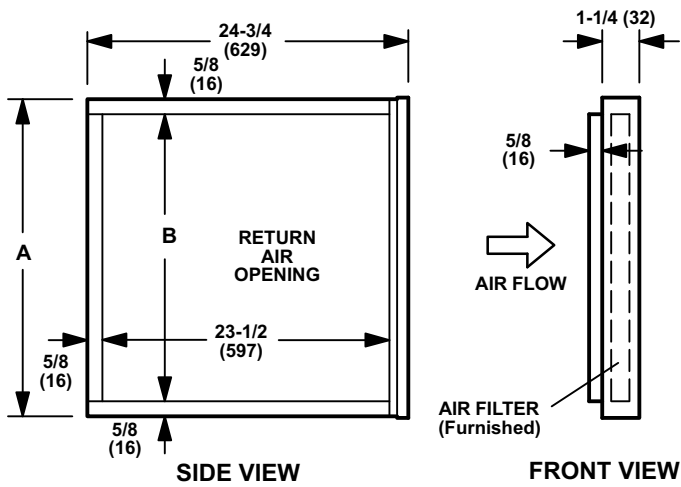

Catalog Number	A		B	
	inch	mm	inch	mm
87L96	18	457	16-3/4	425
87L97	21	533	18-3/4	476
87L98	25	635	23-3/4	603

### CONCENTRIC WALL TERMINATION APPLICATIONS

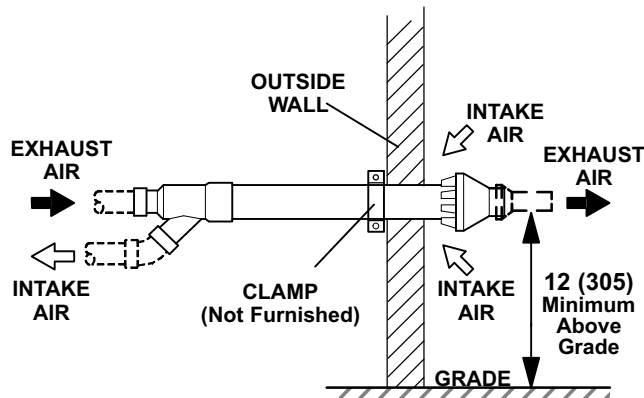

### CONCENTRIC ROOF TERMINATION APPLICATIONS

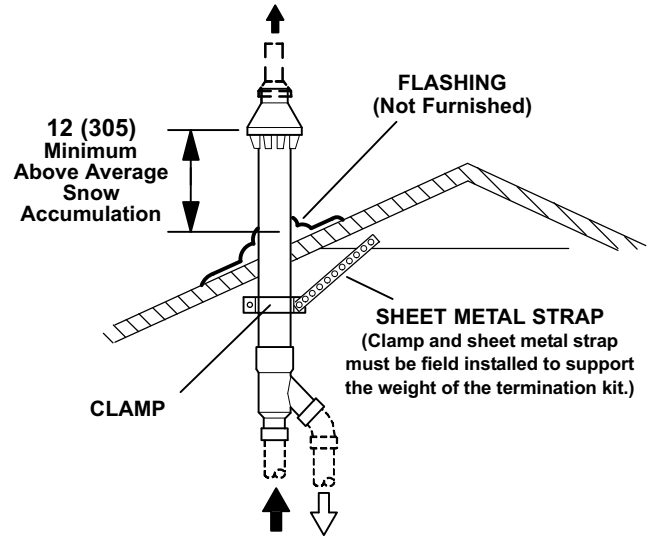

71M80/69M29 - 2 inch (51 mm)  
 60L46 — 3 inch (76 mm)  
 See Installation Instructions for specific usage.

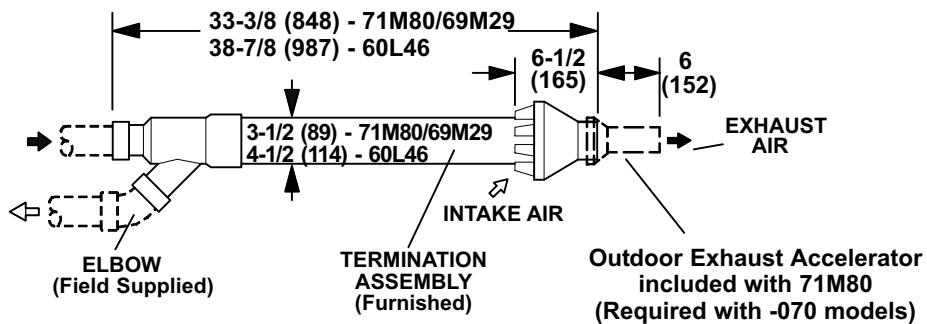

**OPTIONAL ACCESSORY DIMENSIONS - INCHES (MM)**

**WALL ASSEMBLY TERMINATION KIT - RING KIT**

15F74 - 2 inch (51 mm)

See Installation Instructions for specific usage.

**DIRECT VENT APPLICATION**

NOTE - 12 in. (305 mm) minimum height above average snow accumulation.

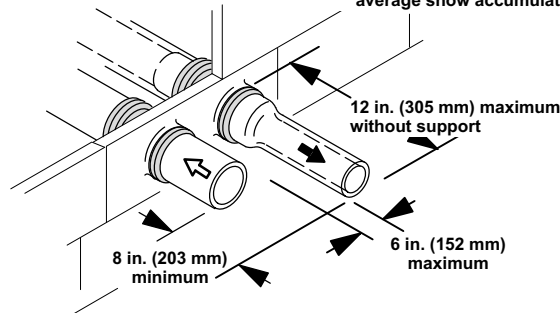

**DIRECT VENT APPLICATIONS**

**WALL TERMINATION KITS (CLOSE-COUPLE)**

22G44 - 2 inch (51 mm)

44J40 - 3 inch (76 mm)

See Installation Instructions for specific usage.

If Intake and Exhaust Pipe is less than 12 in. (305 mm) above snow accumulation or other obstructions, field fabricated piping must be installed.

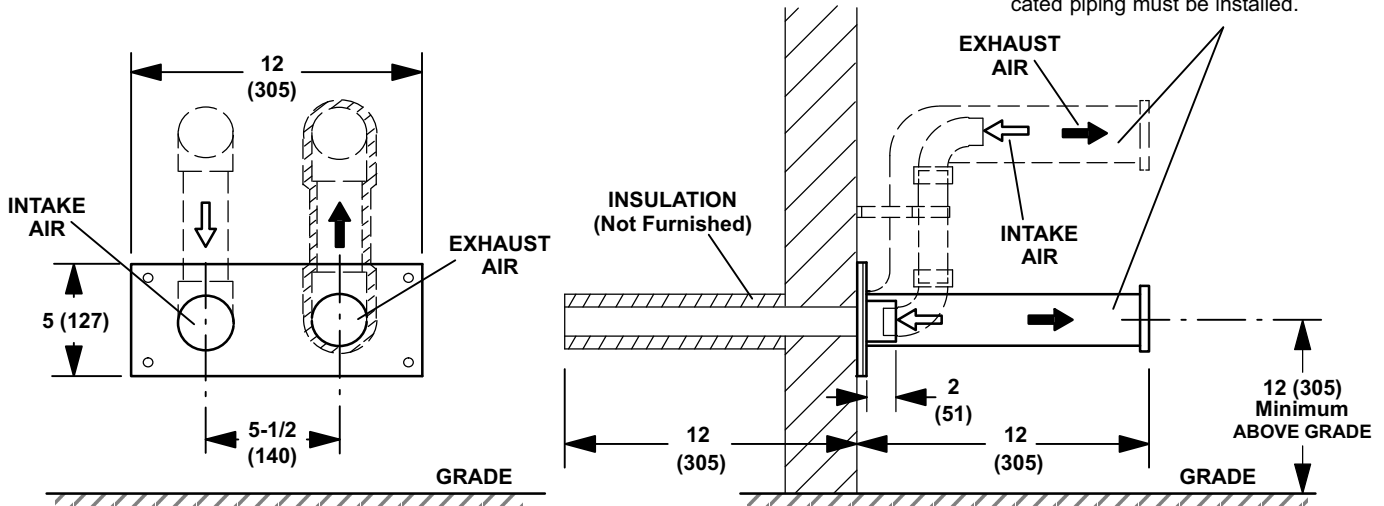

**OPTIONAL ACCESSORY DIMENSIONS - INCHES (MM)**

**DIRECT VENT APPLICATIONS  
WTK WALL ASSEMBLY TERMINATION KIT  
WITH FIELD FABRICATION ABOVE  
GRADE EXTENDED CLEARANCE**

30G28 - 2 inch (51 mm)

81J20 - 3 inch (76mm)

See Installation Instructions for specific usage.

If Intake and Exhaust Pipe is less than 12 in. (305 mm) above snow accumulation or other obstructions, field fabricated piping must be installed.

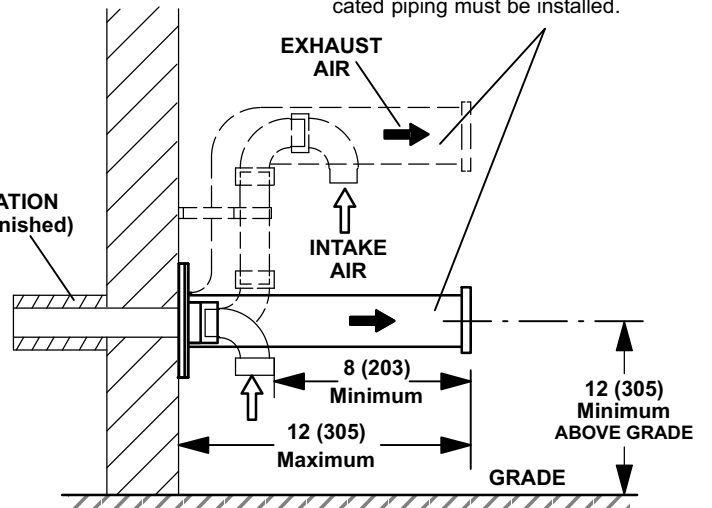
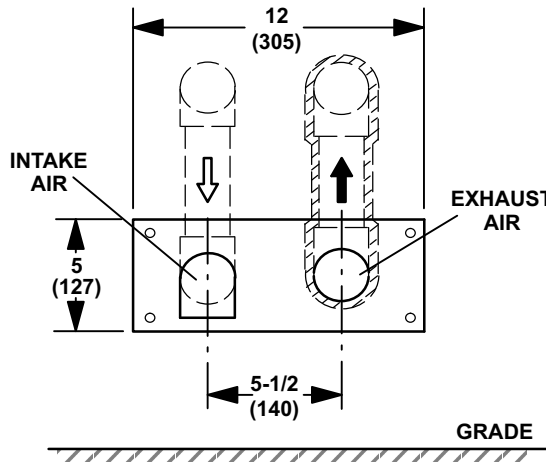

**G71MPP-36B-070 BLOWER PERFORMANCE** (less filter)  
0 through 0.80 in. w.g. External Static Pressure Range

**HEATING BLOWER PERFORMANCE**

Heating Adjust CFM Selections	Heating Input Range and Blower Volume - CFM						
	40%	50%	60%	70%	80%	90%	100%
Increase (+15%) Heat CFM	535	610	690	770	870	975	1075
Increase (+7.5%) Heat CFM	505	575	645	720	810	905	1000
Default Heat CFM	480	545	610	675	760	845	930
Decrease (-7.5%) Heat CFM	460	520	580	640	715	790	870
Decrease (-15%) Heat CFM	440	490	540	590	655	715	780

**COOLING BLOWER PERFORMANCE**

Cooling Adjust CFM Selections	Blower Speed Selections							
	First Stage Cool Speed - cfm				Second Stage Cool Speed - cfm			
	Low	Medium-Low	Medium High	High (Default)	Low	Medium-Low	Medium High	High (Default)
Increase (+10%) Cool CFM	730	815	865	935	1015	1190	1280	1395
Default Cool CFM	680	755	795	855	930	1065	1155	1270
Decrease (-10%) Cool CFM	625	695	730	775	830	950	1010	1105

The effect of static pressure is included in air volumes shown.

Lennox Harmony III™ Zone Control Applications - Minimum blower speed is 250 cfm.

The following control board configurations are available. See Installation Instructions for details and DIP switch settings.

**Heat Mode** (Heating Blower Performance Table):

With two-stage thermostats there are two modes available.

Variable Rate Capacity Mode - furnace automatically adjusts firing rate based on first- and second-stage cycle times. (all columns)

Traditional two-stage mode - W1 demand results in 70% firing rate. W2 results in 100% firing rate. No delay between stages. (values shown in 70% and 100% grey-shaded columns only).

With a single-stage thermostat, furnace will operate at three, staged rates (40/70/100%) with a time delay between each stage (values in grey-shaded columns).

**Cool Mode** (Cooling Blower Performance table):

First stage COOL (two-stage air conditioning units only) is approximately 70% of the same second stage COOL speed position.

Continuous Fan speeds are approximately 28%, 38%, 70% and 100% (DIP switch selectable) of the same second-stage COOL speed position minimum 250 cfm.

**G71MPP-36B-070 BLOWER MOTOR WATTS - COOLING**

Blower Speed Options	Motor Watts @ Various External Static Pressures - in. wg.																	
	First Stage									Second Stage								
	0	0.10	0.20	0.30	0.40	0.50	0.60	0.70	0.80	0	0.10	0.20	0.30	0.40	0.50	0.60	0.70	0.80
<b>Increase (+10%) Cool CFM</b>																		
Low	55	70	90	110	130	145	160	175	190	135	155	175	200	220	245	270	295	320
Medium-Low	75	90	110	130	150	170	190	205	220	185	215	250	285	315	345	370	395	420
Medium-High	85	100	120	145	165	185	205	225	250	235	265	300	335	370	400	425	455	480
High	105	125	150	170	190	210	235	255	280	315	340	370	395	440	480	510	540	570
<b>Default Cool CFM</b>																		
Low	45	60	80	95	115	130	145	160	175	100	120	140	165	190	215	235	255	275
Medium-Low	60	75	95	110	130	145	165	180	200	140	165	190	220	245	265	290	315	340
Medium-High	65	85	105	125	140	155	175	195	215	175	200	230	260	285	310	340	365	390
High	85	100	120	140	160	180	200	220	240	230	260	295	325	360	390	410	435	455
<b>Decrease (-10%) Cool CFM</b>																		
Low	40	55	70	85	100	120	130	145	160	75	90	110	125	150	175	190	210	225
Medium-Low	45	60	80	95	115	135	145	160	175	95	120	150	175	200	220	240	260	285
Medium-High	50	65	85	105	125	145	160	175	190	125	150	175	195	220	240	265	290	320
High	60	75	95	115	135	150	170	190	215	165	190	215	245	265	485	315	340	370

**G71MPP-36C-090 BLOWER PERFORMANCE (less filter)  
0 through 0.80 in. w.g. External Static Pressure Range**

**HEATING BLOWER PERFORMANCE**

Heating Adjust CFM Selections	Heating Input Range and Blower Volume - CFM						
	40%	50%	60%	70%	80%	90%	100%
Increase (+15%) Heat CFM	650	740	825	910	1005	1100	1200
Increase (+7.5%) Heat CFM	620	695	775	850	940	1025	1115
Default Heat CFM	590	655	725	790	870	950	1030
Decrease (-7.5%) Heat CFM	555	615	680	740	815	890	965
Decrease (-15%) Heat CFM	525	575	630	680	745	805	870

**COOLING BLOWER PERFORMANCE**

Cooling Adjust CFM Selections	Blower Speed Selections							
	First Stage Cool Speed - cfm				Second Stage Cool Speed - cfm			
	Low	Medium-Low	Medium High	High (Default)	Low	Medium-Low	Medium High	High (Default)
Increase (+10%) Cool CFM	705	790	845	920	1020	1185	1275	1395
Default Cool CFM	650	730	770	830	905	1060	1145	1270
Decrease (-10%) Cool CFM	600	670	705	750	800	925	1010	1100

The effect of static pressure is included in air volumes shown.

Lennox Harmony III™ Zone Control Applications - Minimum blower speed is 250 cfm.

The following control board configurations are available. See Installation Instructions for details and DIP switch settings.

**Heat Mode** (Heating Blower Performance Table):

With two-stage thermostats there are two modes available.

Variable Rate Capacity Mode - furnace automatically adjusts firing rate based on first- and second-stage cycle times. (all columns)

Traditional two-stage mode - W1 demand results in 70% firing rate. W2 results in 100% firing rate. No delay between stages. (values shown in 70% and 100% grey-shaded columns only).

With a single-stage thermostat, furnace will operate at three, staged rates (40/70/100%) with a time delay between each stage (values in grey-shaded columns).

**Cool Mode** (Cooling Blower Performance table):

First stage COOL (two-stage air conditioning units only) is approximately 70% of the same second stage COOL speed position.

Continuous Fan speeds are approximately 28%, 38%, 70% and 100% (DIP switch selectable) of the same second-stage COOL speed position minimum 250 cfm.

**G71MPP-36C-090 BLOWER MOTOR WATTS - COOLING**

Blower Speed Options	Motor Watts @ Various External Static Pressures - in. wg.																	
	First Stage									Second Stage								
	0	0.10	0.20	0.30	0.40	0.50	0.60	0.70	0.80	0	0.10	0.20	0.30	0.40	0.50	0.60	0.70	0.80
<b>Increase (+10%) Cool CFM</b>																		
Low	35	50	70	90	105	125	140	160	175	85	110	135	160	185	205	235	265	295
Medium-Low	45	60	80	100	125	150	170	185	205	125	155	185	220	245	275	305	330	360
Medium-High	60	75	95	110	135	160	180	200	220	165	195	230	265	300	330	355	380	410
High	65	85	110	135	160	180	205	225	245	210	245	285	325	360	390	425	460	495
<b>Default Cool CFM</b>																		
Low	35	45	60	75	95	115	130	145	160	60	80	110	135	155	175	195	215	235
Medium-Low	40	55	70	90	110	130	150	165	185	105	125	145	170	200	225	250	270	295
Medium-High	45	60	80	95	115	135	155	175	195	115	140	175	205	235	265	290	315	335
High	50	65	85	105	130	155	180	200	220	155	185	220	255	285	315	345	380	415
<b>Decrease (-10%) Cool CFM</b>																		
Low	30	40	55	75	90	105	120	135	150	55	65	85	105	125	150	170	190	210
Medium-Low	40	50	65	80	100	120	130	145	160	65	90	120	145	165	185	205	225	250
Medium-High	40	55	70	90	105	125	140	160	180	85	105	135	165	185	210	235	260	285
High	45	60	75	90	115	135	155	170	190	105	125	150	175	210	240	275	305	335

**G71MPP-60C-090 BLOWER PERFORMANCE** (less filter)  
**Bottom Return Air, Return Air from Both Sides or Return Air from Bottom and One Side**  
**0 through 0.80 in. w.g. External Static Pressure Range**

**HEATING BLOWER PERFORMANCE**

Heating Adjust CFM Selections	Heating Input Range and Blower Volume - CFM						
	40%	50%	60%	70%	80%	90%	100%
Increase (+15%) Heat CFM	665	800	935	1070	1205	1335	1470
Increase (+7.5%) Heat CFM	600	730	860	990	1110	1235	1355
Default Heat CFM	615	715	820	920	1035	1150	1265
Decrease (-7.5%) Heat CFM	520	630	740	850	960	1070	1180
Decrease (-15%) Heat CFM	465	565	665	765	870	970	1075

**COOLING BLOWER PERFORMANCE**

Cooling Adjust CFM Selections	Blower Speed Selections							
	First Stage Cool Speed - cfm				Second Stage Cool Speed - cfm			
	Low	Medium-Low	Medium High	High (Default)	Low	Medium-Low	Medium High	High (Default)
Increase (+10%) Cool CFM	1105	1185	1355	1545	1605	1710	1925	2165
Default Cool CFM	995	1080	1205	1345	1440	1560	1755	1960
Decrease (-10%) Cool CFM	890	960	1090	1215	1275	1380	1590	1755

The effect of static pressure is included in air volumes shown.

Lennox Harmony III™ Zone Control Applications - Minimum blower speed is 450 cfm.

The following control board configurations are available. See Installation Instructions for details and DIP switch settings.

**Heat Mode** (Heating Blower Performance Table):

With two-stage thermostats there are two modes available.

Variable Rate Capacity Mode - furnace automatically adjusts firing rate based on first- and second-stage cycle times. (all columns)

Traditional two-stage mode - W1 demand results in 70% firing rate. W2 results in 100% firing rate. No delay between stages. (values shown in 70% and 100% grey-shaded columns only).

With a single-stage thermostat, furnace will operate at three, staged rates (40/70/100%) with a time delay between each stage (values in grey-shaded columns).

**Cool Mode** (Cooling Blower Performance table):

First stage COOL (two-stage air conditioning units only) is approximately 70% of the same second stage COOL speed position.

Continuous Fan speeds are approximately 28%, 38%, 70% and 100% (DIP switch selectable) of the same second-stage COOL speed position minimum 450 cfm.

**G71MPP-60C-090 BLOWER MOTOR WATTS - COOLING**

**Bottom Return Air, Return Air from Both Sides or Return Air from Bottom and One Side**

Blower Speed Options	Motor Watts @ Various External Static Pressures - in. wg.																	
	First Stage									Second Stage								
	0	0.10	0.20	0.30	0.40	0.50	0.60	0.70	0.80	0	0.10	0.20	0.30	0.40	0.50	0.60	0.70	0.80
<b>Increase (+10%) Cool CFM</b>																		
Low	115	135	160	185	205	230	255	275	300	305	340	375	410	440	475	505	535	565
Medium-Low	145	165	190	215	240	265	285	305	325	355	390	430	470	510	550	580	610	635
Medium-High	170	200	240	275	305	335	370	400	430	510	555	600	645	690	730	765	795	830
High	265	295	330	365	400	435	465	500	535	725	780	835	895	935	975	1005	1035	1065
<b>Default Cool CFM</b>																		
Low	90	110	130	155	175	195	215	235	255	220	250	285	320	350	385	415	450	485
Medium-Low	110	130	155	180	200	220	245	265	285	270	305	345	385	420	455	485	515	545
Medium-High	145	165	190	215	245	270	295	320	340	390	425	465	500	540	580	610	640	670
High	180	205	240	270	300	330	365	395	430	540	580	625	670	710	755	795	830	870
<b>Decrease (-10%) Cool CFM</b>																		
Low	70	85	105	125	145	165	185	205	225	160	190	220	255	275	300	330	360	390
Medium-Low	80	100	120	140	165	190	210	225	245	195	225	260	295	325	350	385	415	450
Medium-High	110	130	160	185	205	225	250	275	300	295	330	365	400	430	460	495	535	570
High	155	175	195	220	245	270	295	315	340	400	435	470	510	545	585	610	640	665

**G71MPP-60C-090 BLOWER PERFORMANCE** (less filter)

**Single Side Return Air** - Air volumes in bold require field fabricated transition to accommodate 20 x 25 x 1 in. cleanable air filter in order to maintain proper air velocity across the filter.

**0 through 0.80 in. w.g. External Static Pressure Range**

**HEATING BLOWER PERFORMANCE**

Heating Adjust CFM Selections	Heating Input Range and Blower Volume - CFM						
	40%	50%	60%	70%	80%	90%	100%
Increase (+15%) Heat CFM	655	790	920	1050	1180	1310	1440
Increase (+7.5%) Heat CFM	605	725	850	970	1090	1205	1325
Default Heat CFM	555	675	790	905	1015	1125	1235
Decrease (-7.5%) Heat CFM	515	625	730	835	940	1045	1150
Decrease (-15%) Heat CFM	465	565	665	765	860	960	1055

**COOLING BLOWER PERFORMANCE**

Cooling Adjust CFM Selections	Blower Speed Selections							
	First Stage Cool Speed - cfm				Second Stage Cool Speed - cfm			
	Low	Medium-Low	Medium High	High (Default)	Low	Medium-Low	Medium High	High (Default)
Increase (+10%) Cool CFM	1080	1160	1315	1490	1575	1690	<b>1895</b>	<b>2135</b>
Default Cool CFM	985	1060	1185	1330	1405	1530	1735	<b>1935</b>
Decrease (-10%) Cool CFM	865	930	1065	1185	1250	1355	1560	1735

The effect of static pressure is included in air volumes shown.

Lennox Harmony III™ Zone Control Applications - Minimum blower speed is 450 cfm.

The following control board configurations are available. See Installation Instructions for details and DIP switch settings.

**Heat Mode** (Heating Blower Performance Table):

With two-stage thermostats there are two modes available.

Variable Rate Capacity Mode - furnace automatically adjusts firing rate based on first- and second-stage cycle times. (all columns)

Traditional two-stage mode - W1 demand results in 70% firing rate. W2 results in 100% firing rate. No delay between stages. (values shown in 70% and 100% grey-shaded columns only).

With a single-stage thermostat, furnace will operate at three, staged rates (40/70/100%) with a time delay between each stage (values in grey-shaded columns).

**Cool Mode** (Cooling Blower Performance table):

First stage COOL (two-stage air conditioning units only) is approximately 70% of the same second stage COOL speed position.

Continuous Fan speeds are approximately 28%, 38%, 70% and 100% (DIP switch selectable) of the same second-stage COOL speed position minimum 450 cfm.

**G71MPP-60C-090 BLOWER MOTOR WATTS - COOLING**

Blower Speed Options	Motor Watts @ Various External Static Pressures - in. wg.																	
	First Stage									Second Stage								
	0	0.10	0.20	0.30	0.40	0.50	0.60	0.70	0.80	0	0.10	0.20	0.30	0.40	0.50	0.60	0.70	0.80
<b>Increase (+10%) Cool CFM</b>																		
Low	110	130	155	180	205	225	245	270	290	285	320	355	390	430	465	500	535	565
Medium-Low	125	150	175	205	225	250	275	300	325	355	390	430	470	500	530	570	605	645
Medium-High	170	195	230	260	290	325	355	385	415	515	550	590	625	670	710	750	795	840
High	240	275	315	355	380	405	445	485	525	740	785	835	885	920	955	990	1020	1050
<b>Default Cool CFM</b>																		
Low	85	100	125	145	170	200	215	235	255	200	230	270	310	340	370	400	430	460
Medium-Low	105	125	150	170	195	220	240	260	280	260	295	330	365	400	440	470	500	530
Medium-High	135	160	185	215	240	270	290	315	335	410	440	470	500	540	580	610	640	670
High	170	200	235	265	305	340	365	390	415	550	585	620	655	695	740	780	825	865
<b>Decrease (-10%) Cool CFM</b>																		
Low	65	80	100	120	140	160	180	205	225	180	215	245	265	290	320	345	375	445
Medium-Low	75	90	110	130	155	180	200	220	245	220	250	275	305	335	370	400	430	510
Medium-High	100	120	150	175	200	220	245	265	290	320	350	385	415	445	485	520	560	635
High	135	160	185	215	240	265	290	315	335	435	465	495	540	585	610	640	665	765

**G71MPP-60C-090 BLOWER PERFORMANCE** (less filter)  
**Side Return Air with Optional RAB Return Air Base**  
**0 through 0.80 in. w.g. External Static Pressure Range**

**HEATING BLOWER PERFORMANCE**

Heating Adjust CFM Selections	Heating Input Range and Blower Volume - CFM						
	40%	50%	60%	70%	80%	90%	100%
Increase (+15%) Heat CFM	645	770	895	1020	1155	1290	1425
Increase (+7.5%) Heat CFM	595	710	825	945	1070	1195	1315
Default Heat CFM	545	660	775	890	1005	1115	1225
Decrease (-7.5%) Heat CFM	505	605	710	810	920	1030	1140
Decrease (-15%) Heat CFM	455	555	650	750	845	945	1045

**COOLING BLOWER PERFORMANCE**

Cooling Adjust CFM Selections	Blower Speed Selections							
	First Stage Cool Speed - cfm				Second Stage Cool Speed - cfm			
	Low	Medium-Low	Medium High	High (Default)	Low	Medium-Low	Medium High	High (Default)
Increase (+10%) Cool CFM	1060	1135	1285	1455	1525	1655	1860	2100
Default Cool CFM	960	1035	1165	1310	1385	1500	1695	1905
Decrease (-10%) Cool CFM	865	920	1050	1165	1240	1320	1510	1695

The effect of static pressure is included in air volumes shown.

Lennox Harmony III™ Zone Control Applications - Minimum blower speed is 450 cfm.

The following control board configurations are available. See Installation Instructions for details and DIP switch settings.

**Heat Mode** (Heating Blower Performance Table):

With two-stage thermostats there are two modes available.

Variable Rate Capacity Mode - furnace automatically adjusts firing rate based on first- and second-stage cycle times. (all columns)

Traditional two-stage mode - W1 demand results in 70% firing rate. W2 results in 100% firing rate. No delay between stages. (values shown in 70% and 100% grey-shaded columns only).

With a single-stage thermostat, furnace will operate at three, staged rates (40/70/100%) with a time delay between each stage (values in grey-shaded columns).

**Cool Mode** (Cooling Blower Performance table):

First stage COOL (two-stage air conditioning units only) is approximately 70% of the same second stage COOL speed position.

Continuous Fan speeds are approximately 28%, 38%, 70% and 100% (DIP switch selectable) of the same second-stage COOL speed position minimum 450 cfm.

**G71MPP-60C-090 BLOWER MOTOR WATTS - COOLING**

**Side Return Air with Optional RAB Return Air Base**

Blower Speed Options	Motor Watts @ Various External Static Pressures - in. wg.																	
	First Stage									Second Stage								
	0	0.10	0.20	0.30	0.40	0.50	0.60	0.70	0.80	0	0.10	0.20	0.30	0.40	0.50	0.60	0.70	0.80
<b>Increase (+10%) Cool CFM</b>																		
Low	110	130	150	175	195	215	240	265	290	275	305	340	380	410	440	470	505	540
Medium-Low	130	155	175	200	220	245	265	290	315	360	390	420	455	485	515	550	590	625
Medium-High	160	190	220	255	280	305	335	360	390	490	530	570	610	645	680	715	750	785
High	220	255	295	330	365	400	430	460	490	695	750	805	855	895	935	965	995	1025
<b>Default Cool CFM</b>																		
Low	80	95	120	140	165	190	210	235	255	190	225	265	305	330	355	390	420	455
Medium-Low	100	120	140	165	190	215	235	255	275	265	295	325	355	390	420	455	495	530
Medium-High	140	160	185	205	235	260	285	305	325	375	410	440	475	500	530	570	610	650
High	180	205	240	270	300	325	350	380	405	520	560	605	645	685	720	760	805	845
<b>Decrease (-10%) Cool CFM</b>																		
Low	70	85	105	125	140	160	180	200	220	155	175	200	225	255	290	315	340	365
Medium-Low	80	95	115	135	155	175	200	220	245	185	210	235	260	295	325	355	385	415
Medium-High	105	125	150	175	200	220	240	265	290	255	290	330	365	400	430	460	490	520
High	135	160	185	215	235	260	285	305	330	370	400	440	475	505	530	565	600	635

**G71MPP-60C-110 BLOWER PERFORMANCE** (less filter)  
**Bottom Return Air, Return Air from Both Sides or Return Air from Bottom and One Side**  
**0 through 0.80 in. w.g. External Static Pressure Range**

**HEATING BLOWER PERFORMANCE**

Heating Adjust CFM Selections	Heating Input Range and Blower Volume - CFM						
	40%	50%	60%	70%	80%	90%	100%
Increase (+15%) Heat CFM	890	1050	1215	1375	1535	1695	1855
Increase (+7.5%) Heat CFM	845	975	1125	1275	1430	1585	1740
Default Heat CFM	800	960	1075	1190	1335	1480	1625
Decrease (-7.5%) Heat CFM	735	860	990	1120	1250	1380	1510
Decrease (-15%) Heat CFM	670	790	910	1030	1145	1260	1375

**COOLING BLOWER PERFORMANCE**

Cooling Adjust CFM Selections	Blower Speed Selections							
	First Stage Cool Speed - cfm				Second Stage Cool Speed - cfm			
	Low	Medium-Low	Medium High	High (Default)	Low	Medium-Low	Medium High	High (Default)
Increase (+10%) Cool CFM	945	1020	1160	1300	1625	1745	1990	2210
Default Cool CFM	840	910	1055	1180	1465	1580	1790	1995
Decrease (-10%) Cool CFM	740	800	920	1045	1290	1405	1605	1790

The effect of static pressure is included in air volumes shown.

Lennox Harmony III™ Zone Control Applications - Minimum blower speed is 450 cfm.

The following control board configurations are available. See Installation Instructions for details and DIP switch settings.

**Heat Mode** (Heating Blower Performance Table):

With two-stage thermostats there are two modes available.

Variable Rate Capacity Mode - furnace automatically adjusts firing rate based on first- and second-stage cycle times. (all columns)

Traditional two-stage mode - W1 demand results in 70% firing rate. W2 results in 100% firing rate. No delay between stages. (values shown in 70% and 100% grey-shaded columns only).

With a single-stage thermostat, furnace will operate at three, staged rates (40/70/100%) with a time delay between each stage (values in grey-shaded columns).

**Cool Mode** (Cooling Blower Performance table):

First stage COOL (two-stage air conditioning units only) is approximately 70% of the same second stage COOL speed position.

Continuous Fan speeds are approximately 28%, 38%, 70% and 100% (DIP switch selectable) of the same second-stage COOL speed position minimum 450 cfm.

**G71MPP-60C-110 BLOWER MOTOR WATTS - COOLING**

**Bottom Return Air, Return Air from Both Sides or Return Air from Bottom and One Side**

Blower Speed Options	Motor Watts @ Various External Static Pressures - in. wg.																	
	First Stage									Second Stage								
	0	0.10	0.20	0.30	0.40	0.50	0.60	0.70	0.80	0	0.10	0.20	0.30	0.40	0.50	0.60	0.70	0.80
<b>Increase (+10%) Cool CFM</b>																		
Low	75	90	115	135	160	180	200	220	240	280	315	350	390	430	475	510	550	585
Medium-Low	90	105	130	150	175	200	220	245	270	340	380	425	465	505	545	575	610	645
Medium-High	120	140	170	195	225	250	275	300	330	510	545	585	620	675	735	770	805	840
High	160	185	210	235	265	290	325	360	395	710	755	805	855	905	950	980	1010	1035
<b>Default Cool CFM</b>																		
Low	55	70	90	110	135	155	175	195	215	205	235	275	310	345	380	415	450	485
Medium-Low	75	90	105	125	150	170	190	215	235	250	285	325	360	400	440	470	505	540
Medium-High	95	115	135	160	190	220	240	265	285	375	410	445	485	530	575	605	635	670
High	125	150	175	200	225	255	280	305	335	510	550	595	640	685	725	770	815	860
<b>Decrease (-10%) Cool CFM</b>																		
Low	45	60	80	100	115	125	145	160	180	155	180	210	240	270	295	325	355	385
Medium-Low	55	70	85	105	125	150	165	185	200	185	215	245	280	315	345	380	415	450
Medium-High	70	85	105	125	150	170	195	215	235	265	300	345	385	425	465	500	535	570
High	95	110	135	160	190	220	240	260	280	375	415	455	495	535	575	615	650	690

**G71MPP-60C-110 BLOWER PERFORMANCE** (less filter)

**Single Side Return Air** - Air volumes in bold require field fabricated transition to accommodate 20 x 25 x 1 in. cleanable air filter in order to maintain proper air velocity across the filter.

**0 through 0.80 in. w.g. External Static Pressure Range**

**HEATING BLOWER PERFORMANCE**

Heating Adjust CFM Selections	Heating Input Range and Blower Volume - CFM						
	40%	50%	60%	70%	80%	90%	100%
Increase (+15%) Heat CFM	870	1030	1185	1345	1490	1630	1775
Increase (+7.5%) Heat CFM	815	955	1095	1240	1380	1525	1670
Default Heat CFM	765	900	1035	1170	1305	1435	1570
Decrease (-7.5%) Heat CFM	715	840	965	1090	1210	1330	1450
Decrease (-15%) Heat CFM	650	765	880	995	1110	1225	1335

**COOLING BLOWER PERFORMANCE**

Cooling Adjust CFM Selections	Blower Speed Selections							
	First Stage Cool Speed - cfm				Second Stage Cool Speed - cfm			
	Low	Medium-Low	Medium High	High (Default)	Low	Medium-Low	Medium High	High (Default)
Increase (+10%) Cool CFM	935	1025	1155	1285	1585	1700	<b>1905</b>	<b>2135</b>
Default Cool CFM	840	915	1050	1175	1435	1535	1740	<b>1930</b>
Decrease (-10%) Cool CFM	750	800	925	1050	1280	1385	1570	1755

The effect of static pressure is included in air volumes shown.

Lennox Harmony III™ Zone Control Applications - Minimum blower speed is 450 cfm.

The following control board configurations are available. See Installation Instructions for details and DIP switch settings.

**Heat Mode** (Heating Blower Performance Table):

With two-stage thermostats there are two modes available.

Variable Rate Capacity Mode - furnace automatically adjusts firing rate based on first- and second-stage cycle times. (all columns)

Traditional two-stage mode - W1 demand results in 70% firing rate. W2 results in 100% firing rate. No delay between stages. (values shown in 70% and 100% grey-shaded columns only).

With a single-stage thermostat, furnace will operate at three, staged rates (40/70/100%) with a time delay between each stage (values in grey-shaded columns).

**Cool Mode** (Cooling Blower Performance table):

First stage COOL (two-stage air conditioning units only) is approximately 70% of the same second stage COOL speed position.

Continuous Fan speeds are approximately 28%, 38%, 70% and 100% (DIP switch selectable) of the same second-stage COOL speed position minimum 450 cfm.

**G71MPP-60C-110 BLOWER MOTOR WATTS - COOLING**

Blower Speed Options	Motor Watts @ Various External Static Pressures - in. wg.																	
	First Stage									Second Stage								
	0	0.10	0.20	0.30	0.40	0.50	0.60	0.70	0.80	0	0.10	0.20	0.30	0.40	0.50	0.60	0.70	0.80
<b>Increase (+10%) Cool CFM</b>																		
Low	70	90	110	130	150	165	185	210	230	255	295	345	390	430	470	510	545	585
Medium-Low	85	105	125	150	170	190	215	235	255	340	375	415	455	490	525	570	615	660
Medium-High	115	135	160	185	210	230	255	285	310	455	500	555	610	655	695	750	800	850
High	155	175	195	220	250	285	310	335	360	650	710	770	835	880	920	960	995	1035
<b>Default Cool CFM</b>																		
Low	60	75	90	110	125	145	165	185	205	195	230	270	305	345	380	415	455	490
Medium-Low	70	85	105	125	140	160	180	200	220	225	265	315	360	400	440	475	515	555
Medium-High	95	110	130	150	175	200	225	245	265	365	400	445	485	525	565	610	650	690
High	115	135	165	190	215	235	260	285	310	495	535	580	625	675	725	770	815	860
<b>Decrease (-10%) Cool CFM</b>																		
Low	45	60	80	100	110	125	140	155	170	155	180	205	235	270	305	340	370	400
Medium-Low	50	65	85	100	120	135	155	175	195	170	200	240	275	315	355	390	420	455
Medium-High	75	90	105	120	140	160	185	210	235	250	290	330	375	410	445	485	525	570
High	95	110	135	155	175	200	225	250	270	365	405	450	490	535	575	615	655	690

**G71MPP-60C-110 BLOWER PERFORMANCE** (less filter)  
**Side Return Air with Optional RAB Return Air Base**  
**0 through 0.80 in. w.g. External Static Pressure Range**

**HEATING BLOWER PERFORMANCE**

Heating Adjust CFM Selections	Heating Input Range and Blower Volume - CFM						
	40%	50%	60%	70%	80%	90%	100%
Increase (+15%) Heat CFM	865	1020	1175	1330	1485	1635	1785
Increase (+7.5%) Heat CFM	805	950	1095	1240	1385	1535	1680
Default Heat CFM	760	895	1030	1165	1300	1435	1570
Decrease (-7.5%) Heat CFM	710	835	960	1090	1210	1335	1460
Decrease (-15%) Heat CFM	645	765	880	1000	1110	1220	1335

**COOLING BLOWER PERFORMANCE**

Cooling Adjust CFM Selections	Blower Speed Selections							
	First Stage Cool Speed - cfm				Second Stage Cool Speed - cfm			
	Low	Medium-Low	Medium High	High (Default)	Low	Medium-Low	Medium High	High (Default)
Increase (+10%) Cool CFM	1085	1155	1310	1475	1555	1685	1895	2130
Default Cool CFM	955	1050	1185	1335	1415	1540	1735	1930
Decrease (-10%) Cool CFM	850	920	1070	1195	1245	1350	1545	1725

The effect of static pressure is included in air volumes shown.

Lennox Harmony III™ Zone Control Applications - Minimum blower speed is 450 cfm.

The following control board configurations are available. See Installation Instructions for details and DIP switch settings.

**Heat Mode** (Heating Blower Performance Table):

With two-stage thermostats there are two modes available.

Variable Rate Capacity Mode - furnace automatically adjusts firing rate based on first- and second-stage cycle times. (all columns)

Traditional two-stage mode - W1 demand results in 70% firing rate. W2 results in 100% firing rate. No delay between stages. (values shown in 70% and 100% grey-shaded columns only).

With a single-stage thermostat, furnace will operate at three, staged rates (40/70/100%) with a time delay between each stage (values in grey-shaded columns).

**Cool Mode** (Cooling Blower Performance table):

First stage COOL (two-stage air conditioning units only) is approximately 70% of the same second stage COOL speed position.

Continuous Fan speeds are approximately 28%, 38%, 70% and 100% (DIP switch selectable) of the same second-stage COOL speed position minimum 450 cfm.

**G71MPP-60C-110 BLOWER MOTOR WATTS - COOLING - Side Return Air with Optional RAB Return Air Base**

Blower Speed Options	Motor Watts @ Various External Static Pressures - in. wg.																	
	First Stage									Second Stage								
	0	0.10	0.20	0.30	0.40	0.50	0.60	0.70	0.80	0	0.10	0.20	0.30	0.40	0.50	0.60	0.70	0.80
<b>Increase (+10%) Cool CFM</b>																		
Low	105	125	150	175	200	220	245	265	290	250	285	320	360	395	435	470	500	535
Medium-Low	130	150	175	200	220	240	270	295	320	335	365	405	445	480	515	550	590	630
Medium-High	165	190	220	250	275	305	335	370	400	470	505	545	585	630	670	710	755	800
High	205	240	285	330	360	390	420	450	485	655	695	745	790	840	885	925	965	1005
<b>Default Cool CFM</b>																		
Low	75	90	115	135	160	185	205	225	250	190	220	255	290	325	360	395	430	460
Medium-Low	100	120	145	165	185	205	230	255	280	250	285	325	360	390	420	455	485	520
Medium-High	135	155	175	200	230	260	280	305	330	355	395	435	475	510	545	580	620	660
High	170	195	225	255	290	320	350	375	405	475	515	565	610	655	705	745	785	825
<b>Decrease (-10%) Cool CFM</b>																		
Low	55	70	90	110	135	155	175	195	220	150	170	200	225	255	285	315	340	370
Medium-Low	65	80	105	130	150	170	195	215	240	165	195	230	265	300	330	360	390	420
Medium-High	100	125	150	180	200	220	240	260	280	240	280	320	360	400	435	470	505	540
High	140	160	180	200	230	260	285	305	330	350	385	420	455	500	540	575	610	645

**G71MPP-60D-135 BLOWER PERFORMANCE** (less filter)  
**Bottom Return Air, Return Air from Both Sides or Return Air from Bottom and One Side**  
**0 through 0.80 in. w.g. External Static Pressure Range**

**HEATING BLOWER PERFORMANCE**

Heating Adjust CFM Selections	Heating Input Range and Blower Volume - CFM						
	40%	50%	60%	70%	80%	90%	100%
Increase (+15%) Heat CFM	1045	1220	1390	1565	1725	1885	2045
Increase (+7.5%) Heat CFM	975	1130	1290	1450	1600	1750	1900
Default Heat CFM	900	1045	1195	1340	1495	1650	1805
Decrease (-7.5%) Heat CFM	840	975	1110	1250	1390	1535	1675
Decrease (-15%) Heat CFM	760	890	1020	1145	1275	1405	1535

**COOLING BLOWER PERFORMANCE**

Cooling Adjust CFM Selections	Blower Speed Selections							
	First Stage Cool Speed - cfm				Second Stage Cool Speed - cfm			
	Low	Medium-Low	Medium High	High (Default)	Low	Medium-Low	Medium High	High (Default)
Increase (+10%) Cool CFM	1135	1205	1365	1540	1615	1730	1945	2190
Default Cool CFM	1025	1105	1235	1390	1455	1580	1780	1985
Decrease (-10%) Cool CFM	915	985	1115	1235	1305	1400	1600	1780

The effect of static pressure is included in air volumes shown.

Lennox Harmony III™ Zone Control Applications - Minimum blower speed is 450 cfm.

The following control board configurations are available. See Installation Instructions for details and DIP switch settings.

**Heat Mode** (Heating Blower Performance Table):

With two-stage thermostats there are two modes available.

Variable Rate Capacity Mode - furnace automatically adjusts firing rate based on first- and second-stage cycle times. (all columns)

Traditional two-stage mode - W1 demand results in 70% firing rate. W2 results in 100% firing rate. No delay between stages. (values shown in 70% and 100% grey-shaded columns only).

With a single-stage thermostat, furnace will operate at three, staged rates (40/70/100%) with a time delay between each stage (values in grey-shaded columns).

**Cool Mode** (Cooling Blower Performance table):

First stage COOL (two-stage air conditioning units only) is approximately 70% of the same second stage COOL speed position.

Continuous Fan speeds are approximately 28%, 38%, 70% and 100% (DIP switch selectable) of the same second-stage COOL speed position minimum 450 cfm.

**G71MPP-60D-135 BLOWER MOTOR WATTS - COOLING**

**Bottom Return Air, Return Air from Both Sides or Return Air from Bottom and One Side**

Blower Speed Options	Motor Watts @ Various External Static Pressures - in. wg.																	
	First Stage									Second Stage								
	0	0.10	0.20	0.30	0.40	0.50	0.60	0.70	0.80	0	0.10	0.20	0.30	0.40	0.50	0.60	0.70	0.80
<b>Increase (+10%) Cool CFM</b>																		
Low	95	120	145	170	190	215	240	265	290	250	285	320	360	390	420	450	485	515
Medium-Low	115	135	160	185	210	235	260	290	315	290	330	375	420	455	490	525	565	605
Medium-High	145	175	215	250	275	300	330	355	385	425	465	505	550	590	635	670	710	750
High	205	240	280	320	350	380	410	445	480	615	655	700	745	800	855	900	940	980
<b>Default Cool CFM</b>																		
Low	80	95	115	135	160	190	210	230	255	185	215	245	280	310	335	370	400	430
Medium-Low	90	115	140	165	190	215	230	250	265	230	260	295	335	370	405	435	470	500
Medium-High	130	150	170	195	225	255	275	300	320	315	355	400	445	480	515	555	590	625
High	150	180	220	255	285	315	345	375	405	445	485	530	580	625	670	705	740	775
<b>Decrease (-10%) Cool CFM</b>																		
Low	65	80	100	120	140	160	180	195	215	145	170	195	225	250	280	305	330	355
Medium-Low	70	90	110	130	155	175	200	220	240	160	190	225	255	285	315	345	380	415
Medium-High	95	120	145	170	190	215	235	250	270	245	280	315	355	385	415	445	480	515
High	135	155	175	200	220	245	270	300	325	325	365	405	445	485	520	550	580	610

**G71MPP-60D-135 BLOWER PERFORMANCE** (less filter)

**Single Side Return Air** - Air volumes in bold require field fabricated transition to accommodate 20 x 25 x 1 in. cleanable air filter in order to maintain proper air velocity across the filter.

**0 through 0.80 in. w.g. External Static Pressure Range**

**HEATING BLOWER PERFORMANCE**

Heating Adjust CFM Selections	Heating Input Range and Blower Volume - CFM						
	40%	50%	60%	70%	80%	90%	100%
Increase (+15%) Heat CFM	995	1160	1325	1490	1640	1790	<b>1940</b>
Increase (+7.5%) Heat CFM	930	1075	1225	1370	1520	1670	<b>1825</b>
Default Heat CFM	865	1005	1145	1280	1425	1570	1715
Decrease (-7.5%) Heat CFM	805	930	1060	1185	1325	1470	1610
Decrease (-15%) Heat CFM	735	850	970	1090	1215	1345	1470

**COOLING BLOWER PERFORMANCE**

Cooling Adjust CFM Selections	Blower Speed Selections							
	First Stage Cool Speed - cfm				Second Stage Cool Speed - cfm			
	Low	Medium-Low	Medium High	High (Default)	Low	Medium-Low	Medium High	High (Default)
Increase (+10%) Cool CFM	1105	1180	1330	1500	1585	1705	<b>1905</b>	<b>2130</b>
Default Cool CFM	990	1075	1210	1355	1430	1545	1765	<b>1975</b>
Decrease (-10%) Cool CFM	890	950	1085	1210	1275	1370	1565	1755

The effect of static pressure is included in air volumes shown.

Lennox Harmony III™ Zone Control Applications - Minimum blower speed is 450 cfm.

The following control board configurations are available. See Installation Instructions for details and DIP switch settings.

**Heat Mode** (Heating Blower Performance Table):

With two-stage thermostats there are two modes available.

Variable Rate Capacity Mode - furnace automatically adjusts firing rate based on first- and second-stage cycle times. (all columns)

Traditional two-stage mode - W1 demand results in 70% firing rate. W2 results in 100% firing rate. No delay between stages. (values shown in 70% and 100% grey-shaded columns only).

With a single-stage thermostat, furnace will operate at three, staged rates (40/70/100%) with a time delay between each stage (values in grey-shaded columns).

**Cool Mode** (Cooling Blower Performance table):

First stage COOL (two-stage air conditioning units only) is approximately 70% of the same second stage COOL speed position.

Continuous Fan speeds are approximately 28%, 38%, 70% and 100% (DIP switch selectable) of the same second-stage COOL speed position minimum 450 cfm.

**G71MPP-60D-135 BLOWER MOTOR WATTS - COOLING**

Blower Speed Options	Motor Watts @ Various External Static Pressures - in. wg.																	
	First Stage									Second Stage								
	0	0.10	0.20	0.30	0.40	0.50	0.60	0.70	0.80	0	0.10	0.20	0.30	0.40	0.50	0.60	0.70	0.80
<b>Increase (+10%) Cool CFM</b>																		
Low	90	110	140	170	195	220	240	265	290	230	265	310	355	390	425	460	490	525
Medium-Low	105	130	165	195	215	235	260	290	315	285	330	380	430	455	485	525	565	605
Medium-High	150	175	205	235	270	300	330	360	385	425	465	515	560	605	645	685	730	770
High	195	230	270	305	340	375	410	445	480	605	650	695	740	800	855	900	945	985
<b>Default Cool CFM</b>																		
Low	70	90	115	135	165	190	210	230	245	170	200	235	265	305	345	380	420	455
Medium-Low	80	100	130	160	185	210	230	255	275	245	270	305	335	370	410	440	470	505
Medium-High	120	140	170	195	225	255	280	305	330	350	385	420	455	495	530	570	610	645
High	145	175	215	250	280	315	345	375	410	455	500	555	605	645	680	725	770	810
<b>Decrease (-10%) Cool CFM</b>																		
Low	60	75	95	115	135	150	175	195	220	140	160	185	205	240	280	305	335	360
Medium-Low	60	75	100	125	150	175	195	215	235	145	180	215	250	290	325	355	385	420
Medium-High	90	110	140	165	190	215	235	255	270	230	265	305	345	380	420	450	480	510
High	120	140	170	195	225	255	275	300	325	330	365	405	445	485	525	560	595	635

**G71MPP-60D-135 BLOWER PERFORMANCE (less filter)**  
**Side Return Air with Optional RAB Return Air Base**  
**0 through 0.80 in. w.g. External Static Pressure Range**

**HEATING BLOWER PERFORMANCE**

Heating Adjust CFM Selections	Heating Input Range and Blower Volume - CFM						
	40%	50%	60%	70%	80%	90%	100%
Increase (+15%) Heat CFM	1020	1180	1340	1500	1650	1800	1955
Increase (+7.5%) Heat CFM	950	1095	1245	1395	1535	1680	1825
Default Heat CFM	885	1020	1160	1300	1435	1575	1715
Decrease (-7.5%) Heat CFM	820	945	1075	1200	1335	1475	1610
Decrease (-15%) Heat CFM	745	870	990	1110	1230	1350	1470

**COOLING BLOWER PERFORMANCE**

Cooling Adjust CFM Selections	Blower Speed Selections							
	First Stage Cool Speed - cfm				Second Stage Cool Speed - cfm			
	Low	Medium-Low	Medium High	High (Default)	Low	Medium-Low	Medium High	High (Default)
Increase (+10%) Cool CFM	1080	1155	1310	1480	1550	1660	1875	2105
Default Cool CFM	985	1055	1190	1325	1400	1510	1720	1920
Decrease (-10%) Cool CFM	875	945	1060	1190	1250	1345	1530	1715

The effect of static pressure is included in air volumes shown.

Lennox Harmony III™ Zone Control Applications - Minimum blower speed is 450 cfm.

The following control board configurations are available. See Installation Instructions for details and DIP switch settings.

**Heat Mode** (Heating Blower Performance Table):

With two-stage thermostats there are two modes available.

Variable Rate Capacity Mode - furnace automatically adjusts firing rate based on first- and second-stage cycle times. (all columns)

Traditional two-stage mode - W1 demand results in 70% firing rate. W2 results in 100% firing rate. No delay between stages. (values shown in 70% and 100% grey-shaded columns only).

With a single-stage thermostat, furnace will operate at three, staged rates (40/70/100%) with a time delay between each stage (values in grey-shaded columns).

**Cool Mode** (Cooling Blower Performance table):

First stage COOL (two-stage air conditioning units only) is approximately 70% of the same second stage COOL speed position.

Continuous Fan speeds are approximately 28%, 38%, 70% and 100% (DIP switch selectable) of the same second-stage COOL speed position minimum 450 cfm.

**G71MPP-60D-135 BLOWER MOTOR WATTS - COOLING - Side Return Air with Optional RAB Return Air Base**

Blower Speed Options	Motor Watts @ Various External Static Pressures - in. wg.																	
	First Stage									Second Stage								
	0	0.10	0.20	0.30	0.40	0.50	0.60	0.70	0.80	0	0.10	0.20	0.30	0.40	0.50	0.60	0.70	0.80
<b>Increase (+10%) Cool CFM</b>																		
Low	90	110	140	165	190	210	235	260	285	235	265	305	340	380	415	450	480	515
Medium-Low	105	130	160	190	210	230	255	285	310	290	325	370	410	450	490	515	545	575
Medium-High	145	170	205	235	265	290	325	355	390	420	460	510	555	595	640	680	715	755
High	200	230	270	305	345	385	415	445	480	580	630	690	745	800	850	895	935	975
<b>Default Cool CFM</b>																		
Low	70	90	115	140	165	190	210	230	250	170	200	235	270	305	335	370	400	430
Medium-Low	90	105	125	150	175	200	225	250	270	200	230	270	310	355	400	435	465	495
Medium-High	115	140	170	195	225	250	275	300	325	330	365	400	440	485	525	555	585	615
High	145	175	205	240	270	295	330	365	395	435	480	530	580	625	675	715	750	790
<b>Decrease (-10%) Cool CFM</b>																		
Low	60	75	95	115	135	155	175	195	215	135	155	180	205	240	280	305	330	355
Medium-Low	70	90	110	130	150	170	195	215	235	160	185	215	240	275	310	345	375	410
Medium-High	85	105	130	155	180	205	230	250	270	220	255	295	335	370	410	440	475	510
High	120	140	170	195	220	240	270	295	325	330	365	400	440	480	525	555	585	615

## REVISIONS

Sections	Description of Change
Specifications	Updated heating outputs.
Termination Kits - Equivalent Vent Lengths table	Placed the 2 in. Concentric Kits (71M80 used with -070 model, 69M29 used with -090-110 models) in separate columns for clarity.



**LENNOX**

Visit us at [www.lennox.com](http://www.lennox.com)

For the latest technical information, [www.lennoxdavenet.com](http://www.lennoxdavenet.com)

Contact us at 1-800-4-LENNOX

NOTE - Due to Lennox' ongoing commitment to quality, Specifications, Ratings and Dimensions subject to change without notice and without incurring liability. Improper installation, adjustment, alteration, service or maintenance can cause property damage or personal injury. Installation and service must be performed by a qualified installer and servicing agency.

©2008 Lennox Industries Inc.