



ENGINEERING DATA

GAS FURNACES

G61MP

ELITE® SERIES

Multi-Position - Two-Stage Heat

Bulletin No. 210382

September 2006

Supersedes August 2006



AFUE - 94.1%

Input - 44,000 to 132,000 Btuh

Nominal Add-on Cooling - 2.5 to 5 Tons

MODEL NUMBER IDENTIFICATION

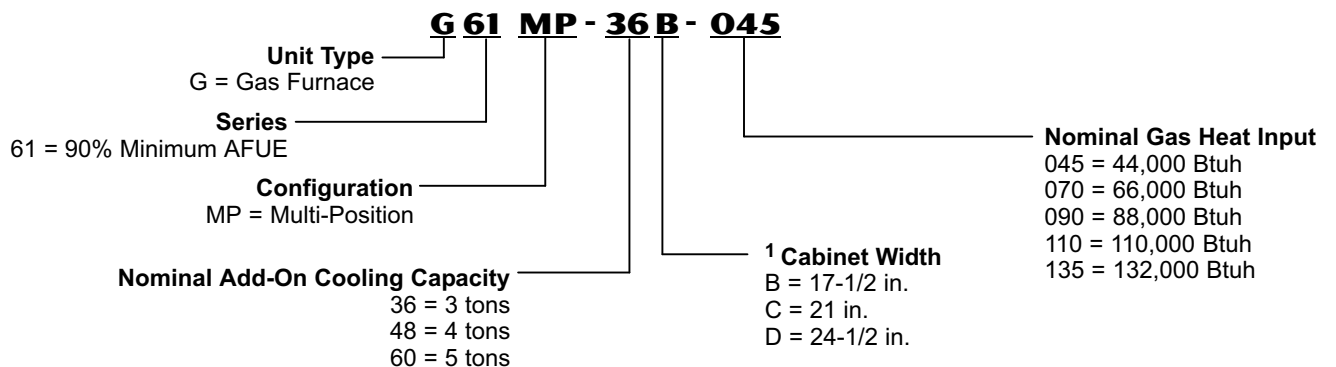

¹ Indoor coils with the same letter designation will physically match the furnace.

FEATURES

CONTENTS

Blower Data	Pages 15-16
Dimensions	Pages 9-14
Exhaust Pipe Venting Information	Page 7
Features and Options	Pages 2-5
Filter Air Resistance	Page 8
Installation Clearances	Page 8
Model Number Identification	Page 1
Optional Accessories Selection Table	Page 6
Specifications	Pages 5

WARRANTY

Duralok Plus® Aluminized Steel **Heat Exchanger** - **Limited lifetime** warranty in residential applications (twenty year transferrable), twenty year limited warranty in non-residential applications.

All other covered components - **Five years** limited warranty in residential applications, one year limited warranty in non-residential applications.

Refer to Lennox Equipment Limited Warranty certificate included with equipment for details.

APPROVALS

Units certified by CSA International and ratings are certified by GAMA.

Units tested and rated according to US DOE test procedures and FTC labeling regulations.

Blower data from unit tests conducted in Lennox Laboratory air test chamber.

Approved by the California Energy Commission and meet California Seasonal Efficiency requirements and California Nitrogen Oxides (NOx) Standards.

ENERGY STAR® certified units are designed to use less energy, help save money on utility bills, and help protect the environment.

ISO 9001 Registered Manufacturing Quality System.

APPLICATIONS

Input capacities of 44,000, 66,000, 88,000, 110,000, and 132,000 Btuh.

Energy efficiency (AFUE) of 94.1% in all four installation configurations.

Compact cabinet for up-flow, down-flow, horizontal-left or horizontal-right applications without any internal modifications to the unit.

Lennox add-on indoor coils, high-efficiency air cleaners and humidifiers can easily be added to furnace.

Shipped factory assembled with all controls installed and wired.

Each unit factory test operated to ensure proper operation.

DIRECT VENT / NON-DIRECT VENT

Furnace can be installed in either Direct Vent or Non-Direct applications. In Direct Vent applications, combustion air is supplied from outdoors and flue gases are discharged outdoors. In Non-Direct Vent applications, combustion air is supplied from indoors and flue gases are discharged outdoors.

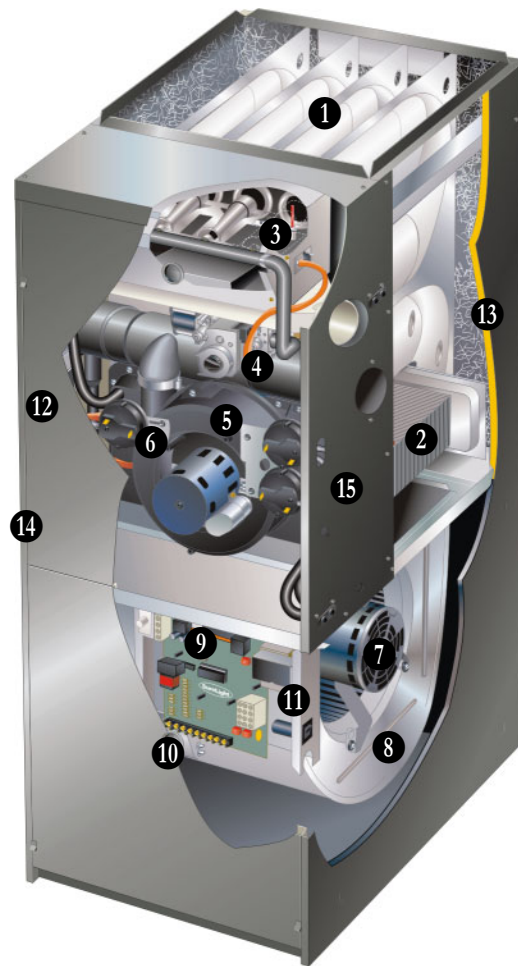

OPTIONS

Termination Kits

Facilitates installation of combustion air intake pipe and flue exhaust pipe.

Refer to venting table in this bulletin to determine pipe size needed and proper termination kit required.

See Specifications table and dimension drawings.

Termination Kit - Concentric - Direct Vent Applications Only

2 or 3 inch kit contains concentric termination assembly, reducer bushing and 45 degree elbow.

2 inch kit for -045-070 models contains an exhaust accelerator.

Kit requires single hole penetration of roof or wall for installation.

Roof Termination Flashing Kit is available for use with 2 inch Kits.

CSA certified.

Termination Kits - Wall Assembly

Close Couple - Direct Vent Applications Only

2 or 3 inch kit consists of close-couple, side-by-side PVC piping with galvanized steel wall cover plate for sealing and isolating piping penetration of the wall.

Piping spacing and length is sized for proper wall installations. CSA certified.

Close Couple WTK - Direct Vent Applications Only

2 or 3 inch kit contains one insulated faceplate, one insulated exhaust pipe, elbow and fittings.

FEATURES

DIRECT VENT / NON-DIRECT VENT - CONTINUED

Wall Ring - Direct or Non-Direct Vent

2 inch kit contains 2 stainless steel outside seal caps, 2 galvanized steel inside seal caps, 4 seal rings for the caps and 18 inch insulation sleeve for sealing and isolating intake and exhaust piping penetration of wall.

Maintain a maximum of 6 inches between the inlet and outlet openings in the installation of the pipes.

Roof Termination Flashing Kit - Direct or Non-Direct Vent

2 or 3 inch (51 or 76 mm) kit contains two neoprene rubber roof flashings for vertical venting through a roof.

Vent pipe and insulation not furnished. Each kit contains enough parts for two non-direct vent installations.

Also available for use with 2 inch (use 3 inch flashing) Concentric Vent Termination Kits used in vertical venting rooftop applications.

HEATING SYSTEM

1 Lennox Duralok Plus® Heat Exchanger Assembly

Lennox developed heat exchanger assembly consists of primary heat exchanger and secondary condenser coil assembly.

Main 3-pass clamshell type heat exchanger constructed of heavy-gauge, aluminized steel.

Designed for normal expansion and contraction.

Crimped seam design and construction provides maximum efficiency and minimum resistance to airflow.

2 Secondary heat exchanger condenser coil constructed of aluminum fins fitted to stainless steel tubes.

Coil is factory tested for leaks.

Condensate drain header box assembly located on front of coil.

Compact size of complete heat exchanger assembly permits low overall design of furnace cabinet.

All components mounted in a heavy-gauge steel frame.

Heat exchanger assembly has been laboratory life cycle tested.

Lennox Designed Header Box

Header box on end of condenser coil collects flue condensate for disposal through condensate collars.

Hose connects the header box drains to the condensate collars.

The condensate collars are located on each side of the cabinet for easy field installation of condensate drain trap.

Only one collar is used, the remainder stay plugged.

Condensate drain trap is included with the unit for field installation.

Lennox Designed Flue Condensate Trap Assembly

Condensate trap assembly is mounted outside the conditioned air stream.

Assembly can be mounted on either side of cabinet in up-flow and down-flow applications. Assembly is mounted on the bottom of the cabinet in horizontal applications. See Installation Instructions.

Connection can be made with field provided 1/2 in. PVC pipe, 3/4 in. PVC coupling, or 1-1/4 in. OD x 1 in. ID tubing with hose clamp.

Easy to clean and winterize.

3 Inshot Burners

Aluminized steel inshot burners provide efficient, trouble-free operation.

Burner venturi mixes air and gas in correct proportion for proper combustion.

Burner assembly is removable from the unit as a single component for ease of service.

4 Two-Stage Gas Control Valve

24 volt redundant combination two stage gas control valve combines manual shut off valve (On-Off), automatic electric valve (dual) and gas pressure regulation into a compact combination control.

Flame Rollout Switch

Manual reset switches are factory installed on burner box. Switch provides protection from abnormal operating conditions.

SureLight® Hot Surface Ignitor

Tough, reliable, long-life, trouble-free performance.

Tungsten heater element sandwiched between two plates of silicon nitride.

Cemented to steatite block for protection against current leakage.

Ignition leads constructed of nickel plated copper enclosed in high temperature Teflon insulation for dependable operation. No electrical noise.

5 Combustion Air Inducer

PSC, heavy-duty blower prepurges heat exchanger and safely vents flue products.

6 Pressure switches prove blower operation before allowing gas valve to open.

Operates only during heating cycle.

Limit Control

Automatic reset, primary and secondary limits are accurately located.

Primary limit factory installed on vestibule panel on all units, secondary limit factory installed on blower housing.

OPTIONS

High Altitude Orifice Kit - Natural Gas Only

Required for all natural gas models for proper unit operation at altitudes of 7501 to 10,000 feet.

Proper orifice for LPG/Propane models is included with LPG/Propane Conversion Kit.

High Altitude Pressure Switch Kit

Required on certain units for proper unit operation on installations above 4,500 ft.

Order two per unit.

LPG/Propane Conversion Kit

Required for field changeover from natural gas to LPG/Propane.

Natural Gas Conversion Kit

Required for field changeover from LPG/Propane to natural gas.

BLOWER

7 Multi-speed, direct drive blower.

Statically and dynamically balanced.

Resiliently mounted.

8 Blower assembly slides out of unit for servicing.

Blower speeds are easily changed on the integrated furnace control board. See blower performance tables.

FEATURES

FILTER (NOT FURNISHED)

Filter and provisions for external mounting must be field provided.

OPTIONS

Air Filter and Rack Kit for Horizontal Return Air (End) Applications

Washable or vacuum cleanable polyurethane frame type filter and external end return air rack available for field installation.

Rack has filter door for easy filter servicing.
Flanges on rack allow easy duct connection.
See dimension drawing.

Air Filter and Rack Kit for Side Return Air Applications (Not for use with RAB Return Air Base)

Washable or vacuum cleanable polyurethane frame type filter and external side return air rack available for field installation.

Available in single and ten pack kits.
Rack has filter door for easy filter servicing.
Flanges on rack allow easy duct connection.
Field installs on either side of unit cabinet.
See dimension drawing.

EZ Filter Base for Bottom Return Air Applications

Hinged door with thumbscrew for easy filter access.
Uses standard size filters (field provided).

CONTROLS

9 SureLight® Integrated Two-Stage Furnace Control Board

Solid-state board contains all necessary controls and relays to operate furnace.

Combustion air inducer is controlled by board. Prior to ignition, a pre-purge cycle for 15 seconds is initiated. After the main burners are turned off, a post-purge cycle for 5 seconds is run.

Adaptive technology of ignition control board continuously monitors and adjusts the ignitor power to operate at minimum ignitor temperature required for ignition, prolonging ignitor life.

Electronic flame sensor control assures safe, reliable operation.

Should loss of flame occur, flame sensor controls will initiate 5 attempts at re-ignition before locking out unit operation for 60 minutes.

Watchguard type circuit automatically resets ignition controls after one hour of continuous thermostat demand after unit lockout, eliminating nuisance calls for service.

Jumper settings for single or two stage thermostat operation.

Two selectable second stage recognition times (10 and 15 minutes) are available on the board when the furnace is used with a single-stage thermostat. When used with a two-stage thermostat, furnace will only initiate second stage operation with a second stage thermostat demand. Fan control consists of adjustable blower timed-off delay (60, 90, 120, 180 seconds - factory setting 90 seconds) and fixed blower timed-on delay (45 seconds).

For air-conditioning applications, blower is automatically energized on thermostat demand for cooling. Adjustable blower timed-off delay in cooling mode (2 or 45 seconds - factory setting 45 seconds).

Terminal for continuous low speed blower operation.

10 Two accessory terminals furnished for additional power supply requirements for 120 volt (less than 1 amp) power humidifiers and powered air cleaners.

Ignition control has two LED's to indicate status and as an aid in troubleshooting.

11 24 Volt Transformer

Furnished and factory installed in control box.
40VA transformer has circuit breaker wired in series.

12 Field Wiring Make-up Box

Furnished for line voltage wiring.
Factory installed internally on left side of furnace.
Box may be installed internally or externally on either side of furnace.

OPTIONS

Thermostat

See Thermostat bulletins in Controls section and Lennox Price Book for a complete list of thermostats.

CABINET

Low-profile, narrow width cabinet allows easy installation in up-flow, down-flow or horizontal applications.

Heavy-gauge, cold rolled steel construction.
Pre-painted cabinet finish.

Flanges provided on supply air opening for ease of plenum connection or alignment with indoor coil.

13 Fully insulated cabinet with foil faced insulation on sides and back of heating compartment and mat faced insulation in blower compartment.

14 Tool-less latches on blower and burner doors assure positive lock.

Complete service access.

Safety interlock switch automatically shuts off power to unit when blower compartment access door is removed.

15 Gas piping and electrical inlets are provided in both sides of cabinet.

Return Air Entry:

For bottom/end return-air entry for up-flow/horizontal applications, remove furnished bottom seal panel from cabinet.

For side return-air entry (up-flow applications only), corners are marked on either side of cabinet for return air cut-outs.

On furnaces with side return air and condensate trap on the same side of the cabinet, a field fabricated transition or RAB is required when using an IAQ product higher than 14-3/16 in. installed next to the unit and serviced from the front. IAQ products higher than 20 in. require a field fabricated transition. See dimension drawings.

NOTE - 60C and 60D size units that require air volumes over 1800 cfm must have one of the following:

1. Single side return air with transition, to accommodate 20 x 25 x 1 in. cleanable air filter, required to maintain proper air velocity.
2. Single side return air with optional RAB Return Air Base.
3. Bottom return air.
4. Return air from both sides.
5. Bottom and one side return air.

See Blower Performance Tables for additional information.

FEATURES

CABINET - CONTINUED

Coil Match-up

All furnaces exactly match C33 and CX34 cased up-flow indoor coils and CH33 horizontal indoor coils with same letter designation in model number. No adaptor required. Engaging holes furnished on cabinet for alignment. C33 uncased coils match furnaces without any overhang but require an optional adaptor base or field fabricated transition to match furnace opening. See C33 coil bulletin for additional information.

All furnaces exactly match CR33 cased, down-flow indoor coils with adaptor rails, furnished with coil.

OPTIONS

Condensate Drain Heat Cable Kits

Self-limiting wattage heat cable prevents condensate drain from freezing in unconditioned areas.

Available in 6, 24 or 50 ft. lengths.

Heat Cable Tape:

66 ft. length, 1/2 in. wide fiberglass.

60 ft. length, 2 in. wide aluminum foil.

Condensate Trap Alternate Location Kit

Allows condensate drain to be installed on the opposite side of the furnace from the exhaust venting (up-flow applications only).

Down-Flow Additive Base

Required for heating only units installed on combustible floors.

Not required in add-on cooling applications.

See Dimension Drawing.

Horizontal Support Frame Kit

Provides support of unit in horizontal applications.

Consists of (2) 1 x 1-1/2 x 32-5/8 in. and (2) 1 x 3 x 53-7/8 in. painted, heavy-gauge cold rolled steel support channels with assembly and suspending holes.

Bolts and nuts furnished for field assembly.

Suspending rods must be field provided.

RAB Return Air Base

On furnaces with side return air and condensate trap on the same side of the cabinet, a field fabricated transition or RAB is required when using an IAQ product higher than 14-3/16 in. installed next to the unit and serviced from the front. IAQ products higher than 20 in. require a field fabricated transition.

Must be used for 60C and 60D models with air volumes over 1800 cfm in up-flow applications when only one side return is required.

Cabinet is pre-painted steel to match the furnace.

See Dimension Drawing.

SPECIFICATIONS

Gas Heating Performance	Model No.	G61MP -36B-045	G61MP -36B-070	G61MP -48C-090	G61MP -60C-090	G61MP -48C-110	G61MP -60C-110	G61MP -60D-135
High Fire	Input - Btuh	44,000	66,000	88,000	88,000	110,000	110,000	132,000
	Output - Btuh	41,000	62,000	83,000	84,000	104,000	104,000	124,000
	Temperature rise range - °F	25 - 55	35 - 65	35 - 65	25 - 55	45 - 75	35 - 65	40 - 70
	Gas Manifold Pressure (in. w.g.) - Nat. Gas / LPG/Propane	3.5 / 10.0	3.5 / 10.0	3.5 / 10.0	3.5 / 10.0	3.5 / 10.0	3.5 / 10.0	3.5 / 10.0
Low Fire	Input - Btuh	30,000	45,000	60,000	60,000	75,000	75,000	90,000
	Output - Btuh	28,000	43,000	57,000	58,000	72,000	72,000	86,000
	Temperature rise range - °F	10 - 40	20 - 50	25 - 55	15 - 45	30 - 60	25 - 55	30 - 60
	Gas Manifold Pressure (in. w.g.) - Nat. Gas / LPG/Propane	1.7 / 4.9	1.7 / 4.9	1.7 / 4.9	1.7 / 4.9	1.7 / 4.9	1.7 / 4.9	1.7 / 4.9
	¹ AFUE	94.1%	94.1%	94.1%	94.1%	94.1%	94.1%	94.1%
	High static (CSA) - in. w.g.	.50	.50	.50	.50	.50	.50	.50
Connections in.	Intake / Exhaust Pipe (PVC)	2 / 2	2 / 2	2 / 2	2 / 2	2 / 2	2 / 2	3 / 3
	Condensate Drain Trap (PVC pipe) - i.d.	1/2	1/2	1/2	1/2	1/2	1/2	1/2
	with field supplied (PVC cplg.) - o.d.	3/4	3/4	3/4	3/4	3/4	3/4	3/4
	hose with hose clamp - i.d. x o.d.	1-1/4 x 1	1-1/4 x 1	1-1/4 x 1	1-1/4 x 1	1-1/4 x 1	1-1/4 x 1	1-1/4 x 1
	Gas pipe size IPS	1/2	1/2	1/2	1/2	1/2	1/2	1/2
Indoor Blower	Wheel nom. dia. x width - in.	10 x 8	10 x 8	10 x 10	11-1/2 x 10	10 x 10	11-1/2 x 10	11-1/2 x 10
	Motor output - hp	1/3	1/3	1/2	1	1/2	1	1
	Tons of add-on cooling	2.5 - 3	2.5 - 3.5	3 - 4	4 - 5	3 - 4	4 - 5	4 - 5
	Air Volume Range - cfm	730 - 1555	710 - 1640	950 - 2180	1440 - 2840	885 - 2160	1470 - 2720	1440 - 2730
Shipping Data	lbs. - 1 package	136	146	168	176	178	186	206
Electrical characteristics		120 volts - 60 hertz - 1 phase (less than 12 amps)						

NOTE - Filters and provisions for mounting are not furnished and must be field provided.

¹ Annual Fuel Utilization Efficiency based on DOE test procedures and according to FTC labeling regulations. Isolated combustion system rating for non-weatherized furnaces.

OPTIONAL ACCESSORIES - MUST BE ORDERED EXTRA

			"B" Width Models	"C" Width Models	"D" Width Models
FILTER KITS					
¹ Air Filter and Rack Kit	Horizontal (end)	Size of filter - in.	87L96 - 18 x 25 x 1	87L97 - 20 x 25 x 1	87L98 - 25 x 25 x 1
	Side Return	Single	44J22	44J22	44J22
		Ten Pack	66K63	66K63	66K63
		Size of filter - in.	16 x 25 x 1	16 x 25 x 1	16 x 25 x 1
EZ Filter Base	Catalog No. - Ship. Wt. - lbs.		73P56 - 7 (3)	73P57 - 8 (4)	73P58 - 10 (5)
	Size of field provided filter - in.		16 x 25 x 1	20 x 25 x 1	24 x 24 x 1

CABINET ACCESSORIES

Down-Flow Additive Base	11M60	11M61	11M62
Horizontal Support Frame Kit	56J18	56J18	56J18
Return Air Base	98M60	98M58	98M59

CONDENSATE DRAIN KITS

Condensate Drain Heat Cable	6 ft.	26K68	26K68	26K68
	24 ft.	26K69	26K69	26K69
	50 ft.	26K70	26K70	26K70
Heat Cable Tape	Fiberglass - 1/2 in. x 66 ft.	39G04	39G04	39G04
	Aluminum foil - 2 in. x 60 ft.	39G03	39G03	39G03
Condensate Trap Alternate Location Kit - Up-Flow Only		76M20	76M20	76M20

CONTROLS

TERMINATION KITS - See Installation Instructions for specific venting information.

² Termination Kits Direct Vent Applications Only	Concentric	2 in.	71M80	69M29	---
		3 in.	---	60L46	60L46
	Wall - Close Couple	2 in.	22G44	---	---
		3 in.	44J40	44J40	44J40
		Close Couple WTK -	2 in.	30G28	---
3 in.	81J20		81J20	81J20	
² Termination Kits - Direct or Non-Direct Vent	Roof	2 in.	15F75	15F75	---
	Wall - Wall Ring Kit	2 in.	15F74	15F74	³ 15F74
² Roof Termination Flashing Kit - Direct or Non-Direct Vent - Contains two flashings.			44J41	44J41	44J41

¹ Cleanable polyurethane frame type filter.

² Kit contains enough parts for two, non-direct vent installations.

³ Non-direct vent only.

GAS HEAT ACCESSORIES

Input	High Altitude Orifice Kit Natural Gas	High Altitude Pressure Switch Kit - Order two each		LPG/Propane Kit		LPG/Propane to Natural Gas Kit	
	7501-10,000 ft.	4501-7500 ft.	7501-10,000 ft.	0-7500 ft.	7501-10,000 ft.	0-7500 ft.	7501-10,000 ft.
-045	59M17	---	---	59M13	59M14	59M87	59M87 + 59M17
-070	59M17	---	56M06	59M13	59M14	59M87	59M87 + 59M17
-090	59M17	75M22	56M21	59M13	59M14	59M87	59M87 + 59M17
-110	59M17	---	75M22	59M13	59M14	59M87	59M87 + 59M17
-135	59M17	56M93	56M93	59M13	59M14	59M87	59M87 + 59M17

EXHAUST PIPE VENTING TABLE

Altitude	Vent Pipe Diameter	¹ Maximum Equivalent Vent Length (feet)				
		G61MP-36B-045	G61MP-36B-070	G61MP-48C-090 G61MP-60C-090	² G61MP-48C-110 ² G61MP-60C-110	³ G61MP-60D-135
0 - 4500 ft.	2 in.	59	59	26	not allowed	not allowed
	2-1/2 in.	65	65	42	32	not allowed
	3 in.	77	78	72	72	⁴ 61
	4 in.	234	214	204	179	160
4501 - 10,000 ft.	2 in.	59	59	26	not allowed	not allowed
	2-1/2 in.	65	65	42	32	not allowed
	3 in.	77	78	72	72	⁴ 46
	4 in.	234	214	204	179	160

NOTE - Minimum Equivalent Vent Pipe length is 15 feet.

¹ "Maximum Equivalent Vent Length" permitted is defined as "Total Length (linear feet) of vent pipe, plus equivalent length (feet) of fittings, plus equivalent length (feet) of termination".

² 110 models installed in up-flow or down-flow applications must have the supplied 90° street ell installed directly into the unit flue collar. The street ell must be included in the elbow count.

³ 135 models installed in up-flow or down-flow applications must have 3 in. to 2 in. reducing elbow (supplied) installed directly into the flue collar. Reducing ell must be included in elbow count.

⁴ 90° elbows must be limited to sweep-type elbows.

VENTING NOTES — One 90° elbow is equivalent to 5 feet of straight vent pipe.

Two 45° elbows are equal to one 90° elbow.

One 45° elbow is equivalent to 2.5 feet of straight vent pipe.

Wall and roof termination (non-concentric) exhaust pipe must terminate with reducer to improve exhaust velocity away from intake piping.

045 and 070 - 2, 2-1/2, 3 or 4 in. - terminate with 1-1/2 in. pipe

090 - 2, 2-1/2, 3 or 4 in. - terminate with 2 in. pipe

110 - 2-1/2, 3 or 4 in. - terminate with 2 in. pipe

135 - 3 or 4 in. - terminate with 2 in. pipe

TERMINATION KITS - EQUIVALENT VENT LENGTHS

Heat Size	Vent Pipe Diameter - in.	Vent Pipe Equivalent Length - feet						
		Concentric Kits		Close Couple Kits		Wall Ring Kit	Outdoor Exhaust Accelerator (Diameter X Length)	
		2 in. ⁴ 71M80 69M29	3 in. 60L46	2 in. 22G44 30G28 (WTK)	3 in. 44J40 81J20 (WTK)	2 in. 15F74	For use with Close Couple and Wall Ring Kits	
						1-1/2 x 12 in.	2 x 12 in.	
-045	2	12	not allowed	4	¹ 4	4	4	not allowed
	2-1/2	15	not allowed	5	¹ 5	5	5	not allowed
	3	41	not allowed	7	¹ 7	7	7	not allowed
	4	42	not allowed	14	¹ 14	14	14	not allowed
-070	2	12	not allowed	4	¹ 4	4	4	not allowed
	2-1/2	15	not allowed	5	¹ 5	5	5	not allowed
	3	24	not allowed	8	¹ 8	8	8	not allowed
	4	42	not allowed	14	¹ 14	14	14	not allowed
-090	2	3	3	not allowed	1	² 1	not allowed	1
	2-1/2	6	6	not allowed	2	² 2	not allowed	2
	3	6	6	not allowed	2	² 2	not allowed	2
	4	12	12	not allowed	4	² 4	not allowed	4
-110	2	3	3	not allowed	1	² 1	not allowed	1
	2-1/2	6	6	not allowed	2	³ 2	not allowed	2
	3	6	6	not allowed	2	³ 2	not allowed	2
	4	12	12	not allowed	4	³ 4	not allowed	4
-135	3	not allowed	15	not allowed	6	³ 6	not allowed	6
	4	not allowed	25	not allowed	10	³ 10	not allowed	10

¹ Requires field provided 1-1/2 in. outdoor exhaust accelerator.

² Requires field provided 2 in. outdoor exhaust accelerator.

³ For use only in non-direct vent applications, when snow riser is not required. Requires field provided 2 in. (51 mm) outdoor exhaust accelerator.

⁴ Outdoor exhaust accelerator included in 71M80 kit; for use with -045-070 models.

INSTALLATION CONFIGURATIONS

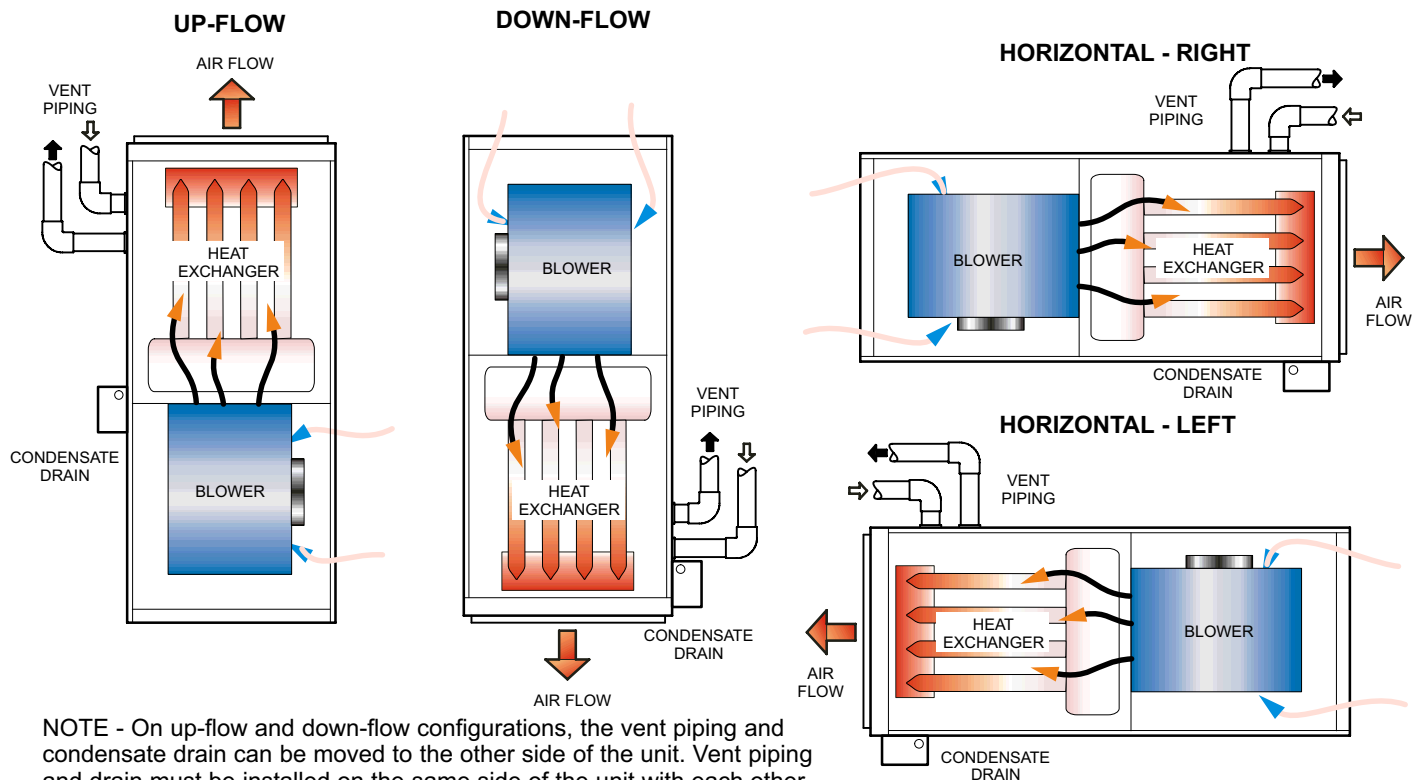

NOTE - On up-flow and down-flow configurations, the vent piping and condensate drain can be moved to the other side of the unit. Vent piping and drain must be installed on the same side of the unit with each other unless optional Condensate Trap Alternate Location Kit (up-flow only) is used. On horizontal installations the drain must be located at the bottom and the vent piping at the top.

FILTER AIR RESISTANCE

For 1 Inch Cleanable Filter (Field Provided)

cfm	in. w.g.
0	0.00
200	0.01
400	0.03
600	0.04
800	0.06
1000	0.09
1200	0.12
1400	0.15
1600	0.19
1800	0.23
2000	0.27
2200	0.33
2400	0.38
2600	0.44

INSTALLATION CLEARANCES

Sides	1 0 inches (0 mm)
Rear	0 inches (0 mm)
Top/Plenum	1 inch (25 mm)
Front	0 inches (0 mm)
Front (service/alcove)	24 inches (610 mm)
Floor	² Combustible

NOTE - Air for combustion and supply air ventilation must conform to the methods outlined in American National Standard (ANSI-Z223.1) National Fuel Gas Code or National Standard of Canada CAN/CGA-149.1, & CAN/CGA-149.2 "Installation Code for Gas Burning Appliances".

NOTE-In the U.S. flue sizing must conform to the methods outlined in current GAMA/A.G.A. venting tables, American National Standard (ANSI-Z223.1) National Fuel Gas Code or applicable provisions of local building codes. In Canada flue sizing must conform to the methods outlined in National Standard of Canada CAN/CGA-149.1 and .2.

¹ Allow proper clearances to accommodate condensate trap and vent pipe installation.

² Clearance for installation on combustible floor if optional additive base is installed between furnace and combustible floor. Not required in add-on cooling applications if installed in accordance with local codes or National Fuel Gas Code ANSI-Z223.1 or CAN/CGA-149.1,.2. Do not install the furnace directly on carpeting, tile, or other combustible materials other than wood flooring.

DIMENSIONS - INCHES (MM) UP-FLOW POSITION SHOWN

¹ NOTE - 60C and 60D size units that require air volumes over 1800 cfm (850 L/s) must have one of the following:

- a. Single side return air with transition, to accommodate 20 x 25 x 1 in. (508 x 635 x 25 mm) air filter. Required to maintain proper air velocity.
- b. Single side return air with optional RAB Return Air Base
- c. Bottom return air.
- d. Return air from both sides.
- e. Bottom and one side return air.

See Blower Performance Tables for additional information.

² Optional External Side Return Air Filter Kit (Up-Flow Only) is not for use with the optional RAB Return Air Base.

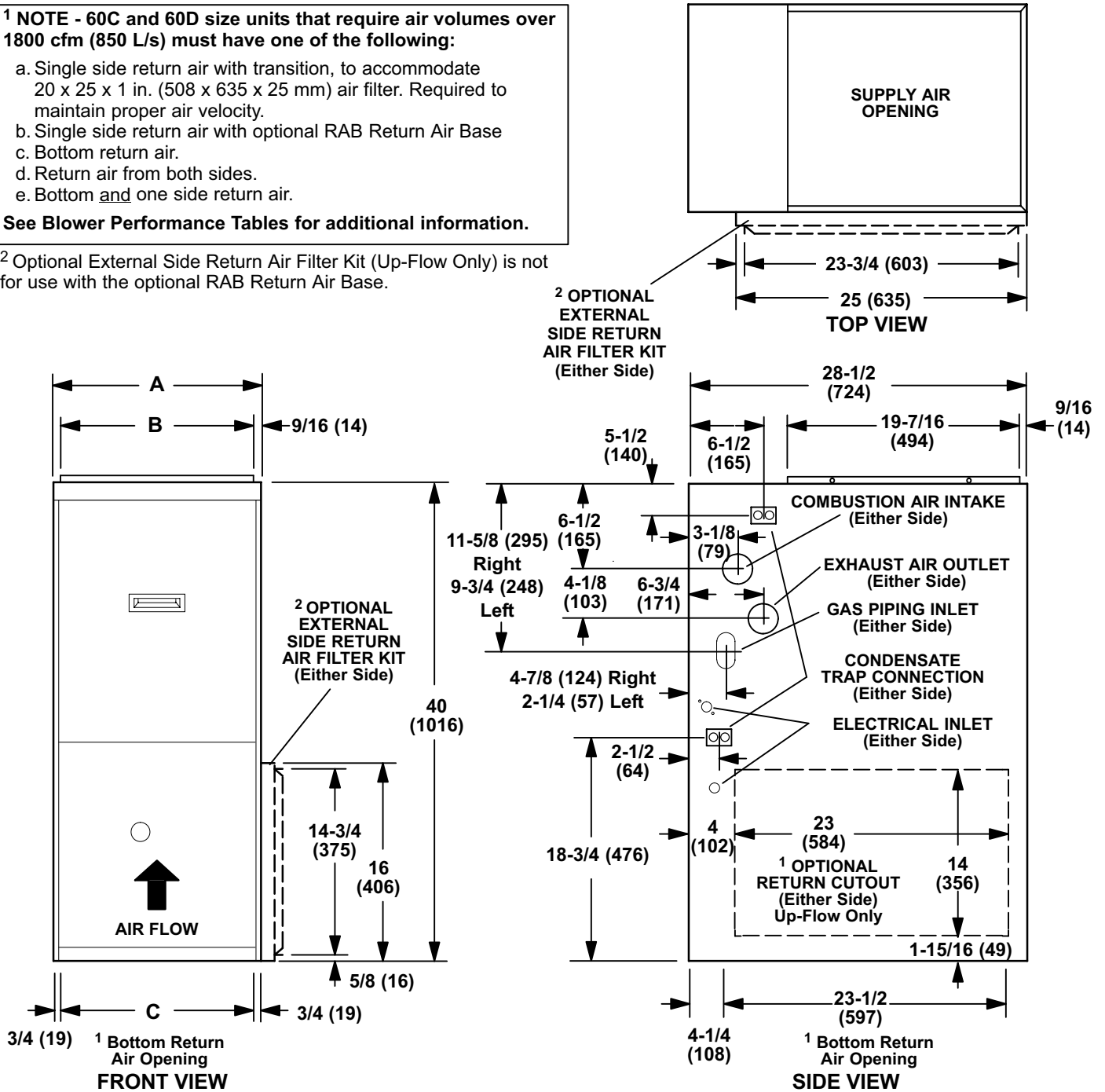

Model No.	A		B		C	
	in.	mm	in.	mm	in.	mm
G61MP-36B-045 G61MP-36B-070	17-1/2	446	16-3/8	416	16	406
G61MP-48C-090 G61MP-60C-090 G61MP-48C-110 G61MP-60C-110	21	533	19-7/8	454	19-1/2	495
G61MP-60D-135	24-1/2	622	23-3/8	546	23	584

DIMENSIONS - INCHES (MM) - FURNACE/COIL COMBINED DIMENSIONS

UP-FLOW POSITION

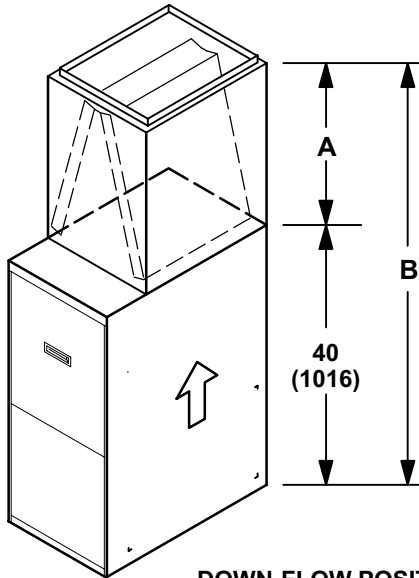

UP-FLOW POSITION

Model No	Cased				Uncased (CX34 - cased only)				
	A		B		A		B		
	in.	mm	in.	mm	in.	mm	in.	mm	
C33-18A	12-1/2	318	52-1/2	1334	9-3/4	248	49-3/4	1264	
CX34-19A-6F	17-1/2	445	57-1/2	1461	9-3/4	248	49-3/4	1264	
C33-24A	16-1/2	419	56-1/2	1435	14	356	54	1372	
CX34-18/24A-6F									
CX34-18/24B-6F	C33-24B				13-7/8	352	53-7/8	1368	
CX34-18/24C-6F	C33-24C								
CX34-25A-6F	C33-25A	19-1/2	495	59-1/2	1511	16-1/4	413	56-1/4	1429
CX34-25B-6F	C33-25B	19-1/2	495	59-1/2	1511	15-7/8	403	55-7/8	1419
CX34-30B-6F	C33-30B	20-1/2	521	60-1/2	1537	17-3/4	451	59-3/4	1467
CX34-30C-6F	C33-30C								
CX34-30A-6F	C33-30A	20-1/2	521	60-1/2	1537	18	457	58	1473
CX34-31A-6F	C33-31A	23-1/2	597	63-1/2	1613	21-1/4	540	61-1/4	1556
CX34-31B-6F	C33-31B	23-1/2	597	63-1/2	1613	20-1/4	514	60-1/4	1530
CX34-36A-6F	C33-36A	24-1/2	622	64-1/2	1638	22-1/8	562	62-1/8	1578
CX34-36B-6F	C33-36B	24-1/2	622	64-1/2	1638	21-7/8	556	61-7/8	1572
CX34-36C-6F	C33-36C	24-1/2	622	64-1/2	1638	21-1/4	540	61-1/4	1556
CX34-38A-6F	C33-38A	24-1/2	622	64-1/2	1638	22-1/4	565	62-1/4	1581
CX34-38B-6F	C33-38B	24-1/2	622	64-1/2	1638	22	559	62	1575
CX34-42B-6F	C33-42B	24-1/2	622	64-1/2	1638	21-7/8	556	61-7/8	1572
CX34-43B-6F	C33-43B	28-1/2	724	68-1/2	1740	26-1/4	667	66-1/4	1683
CX34-43C-6F	C33-43C	28-1/2	724	68-1/2	1740	25-3/4	654	65-3/4	1670
	C33-44C	24-1/2	622	64-1/2	1638	21-1/2	546	61-1/2	1562
CX34-44/48B-6F	C33-48B	24-1/2	622	64-1/2	1638	22-1/8	562	62-1/8	1578
CX34-44/48C-6F	C33-48C	24-1/2	622	64-1/2	1638	21-1/2	546	61-1/2	1562
CX34-49C-6F	C33-49C	29-1/2	749	69-1/2	1765	28-1/2	724	68-1/2	1740
CX34-50/60C-6F	C33-50/60C	27-1/2	699	67-1/2	1715	24-3/4	629	64-3/4	1645
CX34-60D-6F	C33-60D	25-1/2	648	65-1/2	1664	24-3/4	629	64-3/4	1645
CX34-62C-6F	C33-62C	29-1/2	749	69-1/2	1765	30-5/8	778	70-5/8	1793
CX34-62D-6F	C33-62D	29-1/2	749	69-1/2	1765	28-3/4	730	68-3/4	1746

DOWN-FLOW POSITION

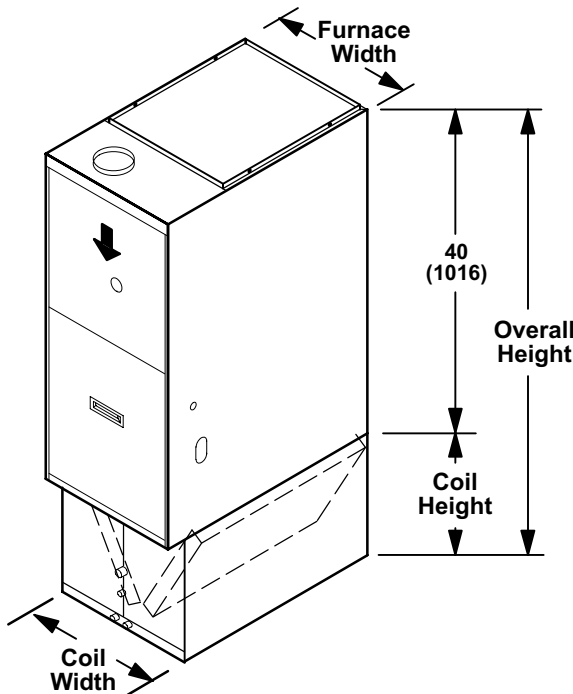

DOWN-FLOW POSITION

Model Number	Coil Width		Furnace Width		Coil Height		Overall Height	
	in.	mm	in.	mm	in.	mm	in.	mm
CR33-18A-F	17-1/2	446	14-1/2	368	14-1/8	359	54-1/8	1375
CR33-24A-F	17-1/2	446	14-1/2	368	13-1/4	337	53-1/4	1353
CR33-24B-F	17-1/2	446	17-1/2	446	13-1/4	337	53-1/4	1353
CR33-30/36A-F	17-1/2	446	14-1/2	368	16-1/8	410	56-1/8	1426
CR33-30/36B-F	17-1/2	446	17-1/2	446	16-1/8	410	56-1/8	1426
CR33-30/36C-F	21	533	21	533	16-1/8	410	56-1/8	1426
CR33-48B-F	21	533	17-1/2	446	20	508	60	1524
CR33-48C-F	21	533	21	533	20	508	60	1524
CR33-50/60C-F	24-1/2	622	21	533	23-5/8	600	53-5/8	1362
CR33-60D-F	24-1/2	622	24-1/2	622	23-5/8	600	53-5/8	1362

HORIZONTAL

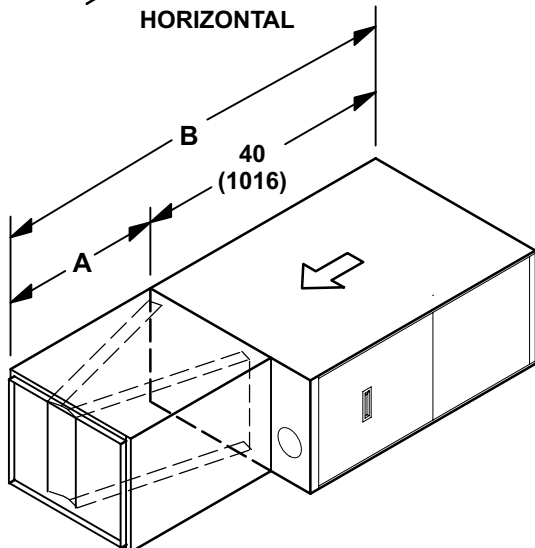

HORIZONTAL POSITION

Model Number	A		B	
	in.	mm	in.	mm
CH33-18A-2F	21-1/2	546	61-1/2	1562
CH33-24/30A-2F				
CH33-36A-2F	26-1/2	673	66-1/2	1689
CH33-36B-2F				
CH33-36C-2F				
CH33-44/48B-2F				
CH33-50/60C-2F	31-1/2	800	71-1/2	1816

OPTIONAL ACCESSORY DIMENSIONS - INCHES (MM)

RAB RETURN AIR BASE (Up-Flow Applications Only)
For use with B, C, and D size furnaces only

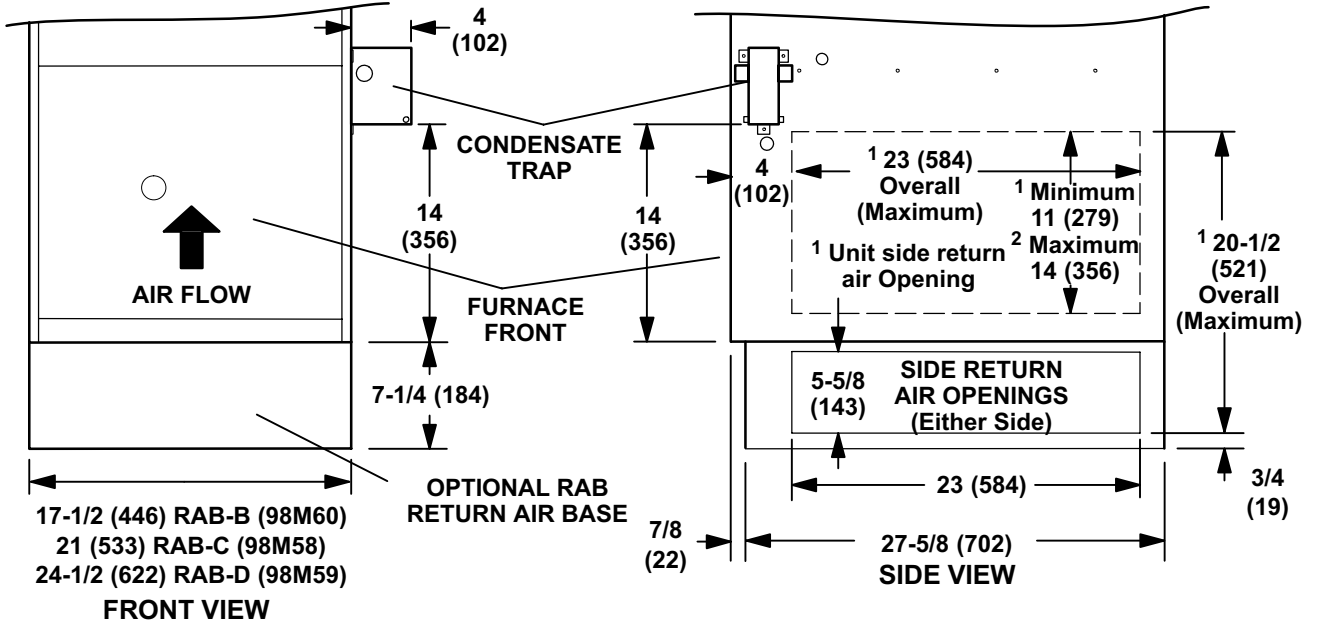

- FRONT VIEW**
- 17-1/2 (446) RAB-B (98M60)
21 (533) RAB-C (98M58)
24-1/2 (622) RAB-D (98M59)
- SIDE VIEW**
- ¹ Both the unit return air opening and the base return air opening must be covered by a single plenum or IAQ cabinet. Minimum unit side return air opening dimensions for units requiring 1800 cfm or more of air (W x H): 23 x 11 in. (584 x 279 mm). The opening can be cut as needed to accommodate plenum or IAQ cabinet while maintaining dimensions shown. Side return air openings must be cut in the field. There are cutting guides stenciled on the cabinet for the side return air opening. The size of the opening must not extend beyond the markings on the furnace cabinet.
- ² 14 inches (356 mm) is the maximum size the height of the unit opening can be cut. This may interfere with the condensate drain (if located on the same side of the unit as the opening). To minimize pressure drop, the largest opening height possible (up to 14 inches) is preferred.
- NOTE- Optional Side Return Air Filter Kits are not for use with RAB Return Air Base.

DOWN-FLOW ADDITIVE FLOOR BASE

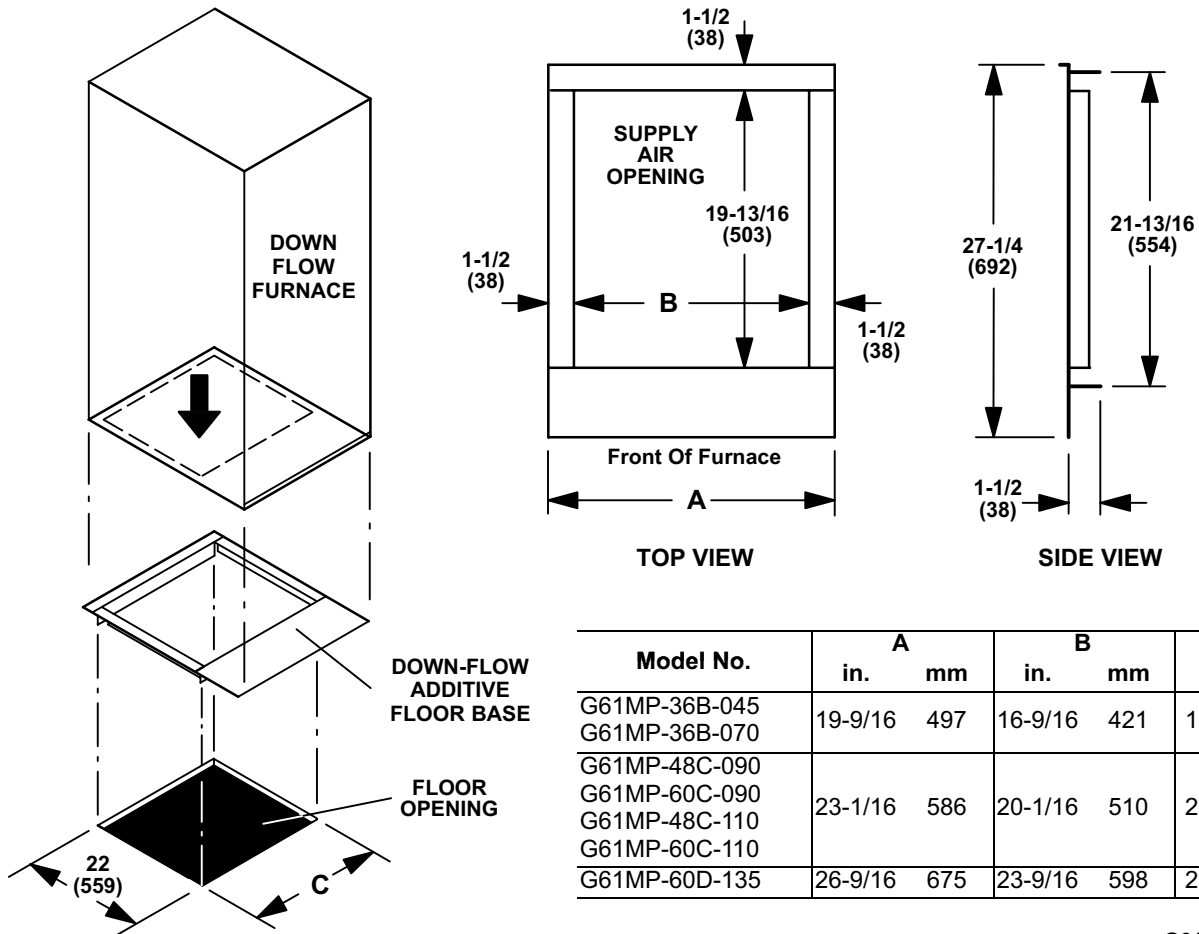

Model No.	A		B		C	
	in.	mm	in.	mm	in.	mm
G61MP-36B-045	19-9/16	497	16-9/16	421	18-3/4	476
G61MP-36B-070						
G61MP-48C-090						
G61MP-60C-090	23-1/16	586	20-1/16	510	22-1/4	565
G61MP-48C-110						
G61MP-60C-110						
G61MP-60D-135	26-9/16	675	23-9/16	598	25-3/4	654

OPTIONAL ACCESSORY DIMENSIONS - INCHES (MM)

HORIZONTAL FILTER KIT

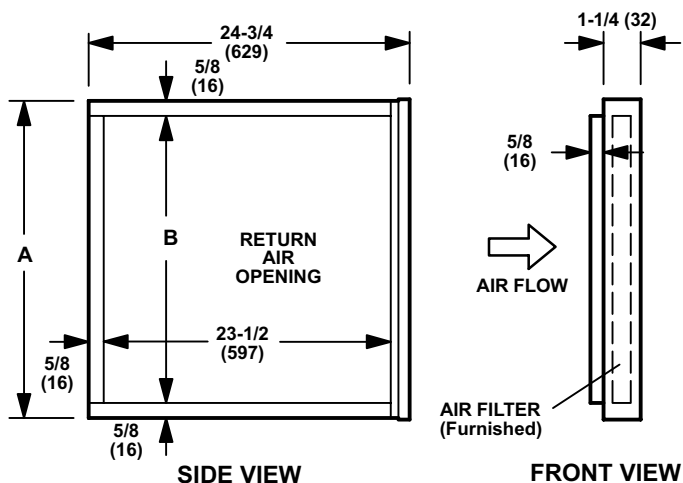

Catalog Number	A		B	
	inch	mm	inch	mm
87L96	18	457	16-3/4	425
87L97	21	533	18-3/4	476
87L98	25	635	23-3/4	603

CONCENTRIC WALL TERMINATION APPLICATIONS

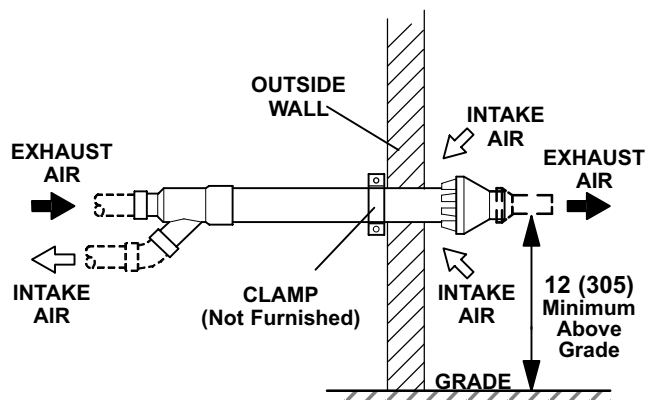

CONCENTRIC ROOF TERMINATION APPLICATIONS

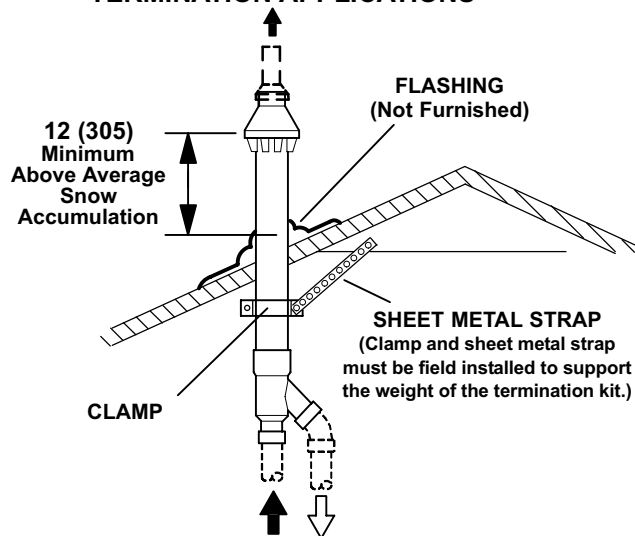

71M80/69M29 - 2 inch (51 mm)
60L46 — 3 inch (76 mm)
 See Installation Instructions for specific usage.

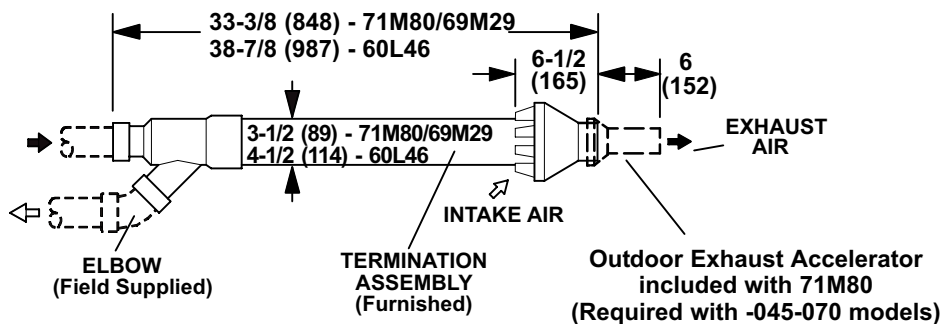

OPTIONAL ACCESSORY DIMENSIONS - INCHES (MM)

WALL ASSEMBLY TERMINATION KIT - RING KIT 15F74 - 2 inch (51 mm)

See Installation Instructions for specific usage.

DIRECT VENT APPLICATION

NOTE - 12 in. (305 mm) minimum height above average snow accumulation.

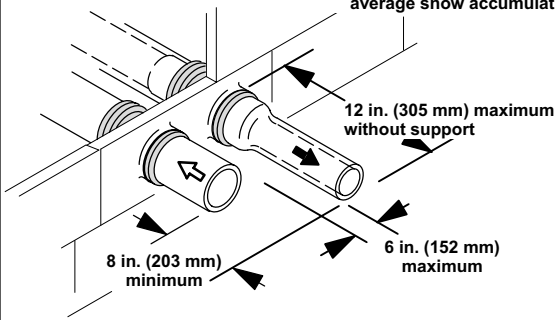

NON-DIRECT VENT APPLICATION

NOTE — EXHAUST PIPE SHOWN
Kit Contains Enough Parts For Two Installations

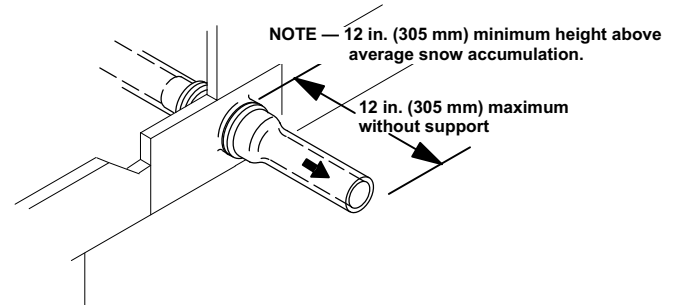

DIRECT VENT APPLICATIONS

WALL TERMINATION KITS (CLOSE-COUPLE)

22G44 - 2 inch (51 mm)

44J40 - 3 inch (76 mm)

See Installation Instructions for specific usage.

If Intake and Exhaust Pipe is less than 12 in. (305 mm) above snow accumulation or other obstructions, field fabricated piping must be installed.

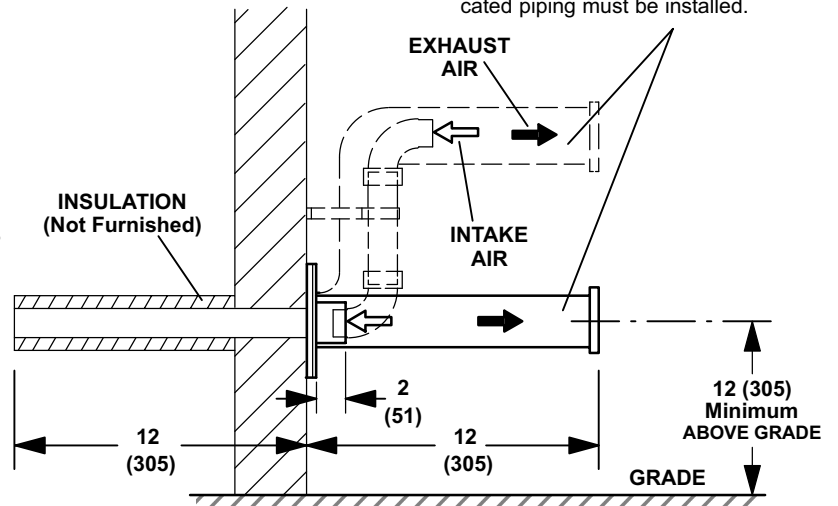
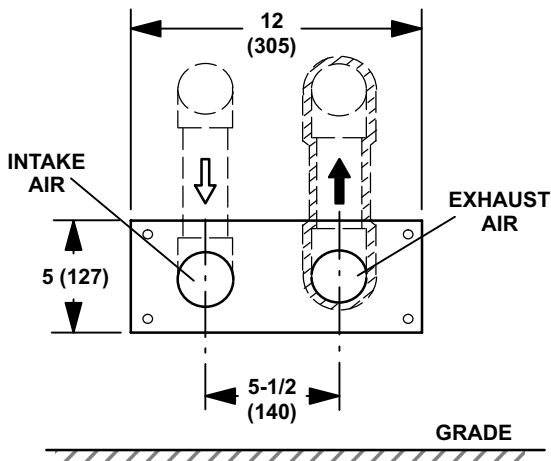

OPTIONAL ACCESSORY DIMENSIONS - INCHES (MM)

**DIRECT VENT APPLICATIONS
WTK WALL ASSEMBLY TERMINATION KIT
WITH FIELD FABRICATION ABOVE
GRADE EXTENDED CLEARANCE**

30G28 - 2 inch (51 mm)

81J20 - 3 inch (76 mm)

See Installation Instructions for specific usage.

If Intake and Exhaust Pipe is less than 12 in. (305 mm) above snow accumulation or other obstructions, field fabricated piping must be installed.

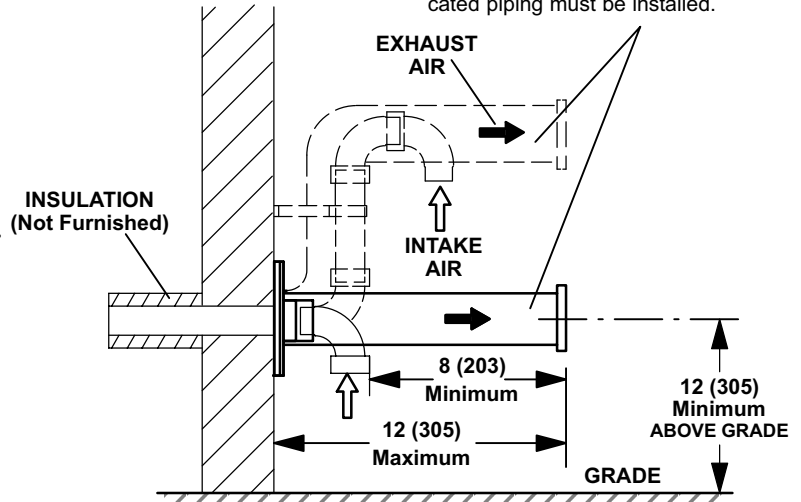
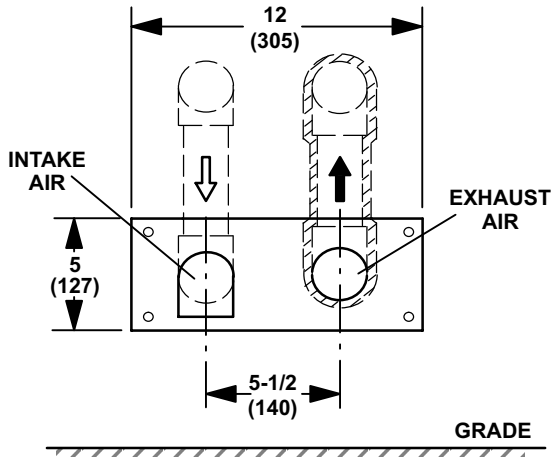

BLOWER/WATTS DATA

G61MP-36B-045 PERFORMANCE (Less Filter)

External Static Pressure in. w.g.	Air Volume / Watts at Different Blower Speeds							
	High		Medium-High		Medium-Low		Low	
	cfm	Watts	cfm	Watts	cfm	Watts	cfm	Watts
0.00	1555	630	1410	585	1190	520	1030	435
0.10	1515	605	1385	555	1190	485	1020	415
0.20	1470	580	1345	520	1170	455	1010	400
0.30	1410	555	1310	495	1155	440	1000	385
0.40	1350	535	1250	465	1120	410	980	360
0.50	1290	505	1205	450	1080	390	950	345
0.60	1220	485	1145	420	1020	365	905	320
0.70	1145	460	1080	400	975	345	860	300
0.80	1050	425	985	365	870	320	785	285
0.90	945	410	900	345	825	305	730	270

NOTES - All air data is measured external to unit without filter (not furnished - field provided).
Air volume based on bottom air return air. Actual air volume may vary on side return air applications.

G61MP-48C-090 PERFORMANCE (Less Filter)

External Static Pressure in. w.g.	Air Volume / Watts at Different Blower Speeds							
	High		Medium-High		Medium-Low		Low	
	cfm	Watts	cfm	Watts	cfm	Watts	cfm	Watts
0.00	2180	930	1835	790	1520	630	1280	510
0.10	2135	885	1825	750	1510	610	1275	495
0.20	2085	840	1810	720	1505	580	1270	475
0.30	2030	800	1775	685	1500	565	1265	460
0.40	1940	760	1735	650	1480	535	1250	440
0.50	1865	725	1660	600	1430	505	1215	425
0.60	1740	670	1590	575	1380	475	1175	410
0.70	1645	640	1475	520	1290	450	1105	375
0.80	1540	600	1340	465	1175	405	1020	355
0.90	1335	540	1170	440	1070	375	950	330

NOTES - All air data is measured external to unit without filter (not furnished - field provided).
Air volume based on bottom air return air. Actual air volume may vary on side return air applications.

G61MP-60C-090 PERFORMANCE (Less Filter)

External Static Pressure in. w.g.	Air Volume / Watts at Different Blower Speeds															
	Bottom Return Air, Side Return Air with Optional RAB Return Air Base, Return Air from Both Sides or Return Air from Bottom and One Side.						Single Side Return Air - Air volumes in bold require field fabricated transition to accommodate 20 x 25 x 1 in. air filter in order to maintain proper air velocity.									
	High		Medium-High		Medium-Low		Low		High		Medium-High		Medium-Low		Low	
cfm	Watts	cfm	Watts	cfm	Watts	cfm	Watts	cfm	Watts	cfm	Watts	cfm	Watts	cfm	Watts	
0.00	2840	1450	2345	1105	1895	900	1515	700	2835	1495	2340	1155	1800	895	1440	695
0.10	2765	1415	2365	1080	1950	885	1580	700	2785	1475	2345	1135	1805	865	1515	690
0.20	2695	1385	2345	1050	1985	870	1620	695	2715	1435	2275	1080	1825	845	1560	685
0.30	2605	1335	2315	1030	1990	850	1645	690	2620	1380	2260	1035	1840	825	1600	680
0.40	2530	1300	2265	990	1990	825	1665	675	2550	1350	2230	1015	1845	815	1620	670
0.50	2420	1260	2210	955	1970	800	1675	665	2450	1305	2175	990	1850	790	1615	655
0.60	2330	1220	2145	925	1930	775	1665	650	2365	1270	2130	940	1830	775	1615	640
0.70	2250	1190	2050	885	1875	745	1645	630	2240	1205	2070	915	1815	760	1595	620
0.80	2135	1140	2000	865	1810	715	1620	615	2185	1190	1965	865	1775	745	1555	605
0.90	2030	1090	1885	830	1720	685	1560	590	2015	1150	1820	820	1690	715	1440	580

NOTES - All air data is measured external to unit without filter (not furnished - field provided).

G61MP-36B-070 PERFORMANCE (Less Filter)

External Static Pressure in. w.g.	Air Volume / Watts at Different Blower Speeds							
	High		Medium-High		Medium-Low		Low	
	cfm	Watts	cfm	Watts	cfm	Watts	cfm	Watts
0.00	1640	660	1415	575	1160	485	1005	410
0.10	1600	635	1395	550	1160	460	1000	385
0.20	1540	605	1370	525	1160	445	995	375
0.30	1495	580	1345	505	1145	425	990	365
0.40	1420	545	1275	480	1125	395	965	345
0.50	1360	525	1245	450	1080	375	945	325
0.60	1275	490	1165	410	1025	350	900	305
0.70	1170	465	1085	385	965	335	860	295
0.80	1080	440	1010	360	865	310	775	270
0.90	945	400	840	320	765	275	710	245

G61MP-48C-110 PERFORMANCE (Less Filter)

External Static Pressure in. w.g.	Air Volume / Watts at Different Blower Speeds							
	High		Medium-High		Medium-Low		Low	
	cfm	Watts	cfm	Watts	cfm	Watts	cfm	Watts
0.00	2160	880	1880	755	1490	602	1235	485
0.10	2100	850	1855	730	1480	585	1230	475
0.20	2035	805	1815	690	1475	560	1225	460
0.30	1965	750	1755	650	1475	545	1220	445
0.40	1885	725	1715	625	1465	510	1215	430
0.50	1780	680	1630	580	1420	490	1150	400
0.60	1690	660	1550	550	1360	460	1110	380
0.70	1575	620	1410	505	1210	405	1035	350
0.80	1375	550	1230	450	1125	380	970	325
0.90	1225	520	1120	415	1050	365	885	310

BLOWER/WATTS DATA

G61MP-60C-110 PERFORMANCE (Less Filter)

External Static Pressure in. w.g.	Air Volume / Watts at Different Blower Speeds								Air Volume / Watts at Different Blower Speeds							
	Bottom Return Air, Side Return Air with Optional RAB Return Air Base, Return Air from Both Sides or Return Air from Bottom and One Side.								Single Side Return Air - Air volumes in bold require field fabricated transition to accommodate 20 x 25 x 1 in. air filter in order to maintain proper air velocity.							
	High		Medium-High		Medium-Low		Low		High		Medium-High		Medium-Low		Low	
	cfm	Watts	cfm	Watts	cfm	Watts	cfm	Watts	cfm	Watts	cfm	Watts	cfm	Watts	cfm	Watts
0.00	2720	1385	2410	1090	2055	935	1620	710	2625	1350	2310	1080	1885	885	1515	700
0.10	2665	1355	2385	1075	2025	885	1730	735	2570	1330	2325	1060	1910	865	1575	700
0.20	2585	1315	2350	1015	2030	865	1680	690	2410	1305	2285	1035	1930	845	1620	690
0.30	2505	1275	2290	990	2025	840	1695	675	2425	1265	2230	990	1925	825	1635	675
0.40	2435	1250	2235	940	2030	830	1695	660	2335	1220	2175	950	1910	810	1640	660
0.50	2350	1205	2170	930	1975	790	1735	665	2270	1195	2120	935	1895	785	1640	640
0.60	2255	1185	2100	895	1915	765	1720	650	2170	1155	2045	885	1860	765	1630	630
0.70	2160	1150	2005	840	1865	730	1680	635	2110	1130	1950	855	1795	730	1590	610
0.80	2020	1090	1905	825	1810	710	1625	610	2035	1090	1885	820	1745	705	1540	580
0.90	1910	1050	1820	795	1705	675	1540	590	1900	1055	1760	780	1665	680	1470	565

NOTES - All air data is measured external to unit without filter (not furnished - field provided).

G61MP-60D-135 PERFORMANCE (Less Filter)

External Static Pressure in. w.g.	Air Volume / Watts at Different Blower Speeds								Air Volume / Watts at Different Blower Speeds							
	Bottom Return Air, Side Return Air with Optional RAB Return Air Base, Return Air from Both Sides or Return Air from Bottom and One Side.								Single Side Return Air - Air volumes in bold require field fabricated transition to accommodate 20 x 25 x 1 in. air filter in order to maintain proper air velocity.							
	High		Medium-High		Medium-Low		Low		High		Medium-High		Medium-Low		Low	
	cfm	Watts	cfm	Watts	cfm	Watts	cfm	Watts	cfm	Watts	cfm	Watts	cfm	Watts	cfm	Watts
0.00	2730	1465	2425	1125	2055	915	1560	680	2665	1440	2325	1100	1865	890	1410	690
0.10	2670	1440	2400	1100	2065	890	1590	675	2615	1405	2310	1065	1915	865	1465	685
0.20	2600	1400	2365	1070	2045	865	1620	665	2530	1370	2280	1055	1925	850	1570	675
0.30	2525	1360	2315	1045	2035	845	1615	655	2470	1330	2235	1015	1920	825	1590	670
0.40	2445	1325	2260	1015	2020	820	1615	645	2380	1290	2175	985	1910	805	1590	655
0.50	2360	1280	2195	985	1960	790	1610	635	2310	1265	2120	965	1890	790	1595	645
0.60	2290	1255	2130	965	1900	755	1600	615	2200	1230	2055	935	1835	765	1580	630
0.70	2205	1220	2035	910	1825	730	1570	600	2120	1190	1970	900	1790	740	1545	605
0.80	2110	1195	1945	880	1765	710	1540	580	2025	1160	1890	875	1720	710	1515	590
0.90	1970	1120	1835	830	1680	690	1540	545	1930	1110	1800	835	1655	685	1440	570

NOTES - All air data is measured external to unit without filter (not furnished - field provided).



Visit us at www.lennox.com

For the latest technical information, www.lennoxdavenet.com

Contact us at 1-800-4-LENNOX

NOTE - Due to Lennox' ongoing commitment to quality, Specifications, Ratings and Dimensions subject to change without notice and without incurring liability. Improper installation, adjustment, alteration, service or maintenance can cause property damage or personal injury. Installation and service must be performed by a qualified installer and servicing agency.

©2006 Lennox Industries Inc.