



ENGINEERING DATA

G60UHV

DAVE LENNOX SIGNATURE® COLLECTION
Up-Flow / Horizontal - Two-Stage Heat - Variable Speed Blower

Bulletin No. 210346
 August 2006
 Supersedes August 2005



AFUE - 80%
Input - 66,000 to 132,000 Btuh
Nominal Add-on Cooling - 2 to 5 Tons

MODEL NUMBER IDENTIFICATION

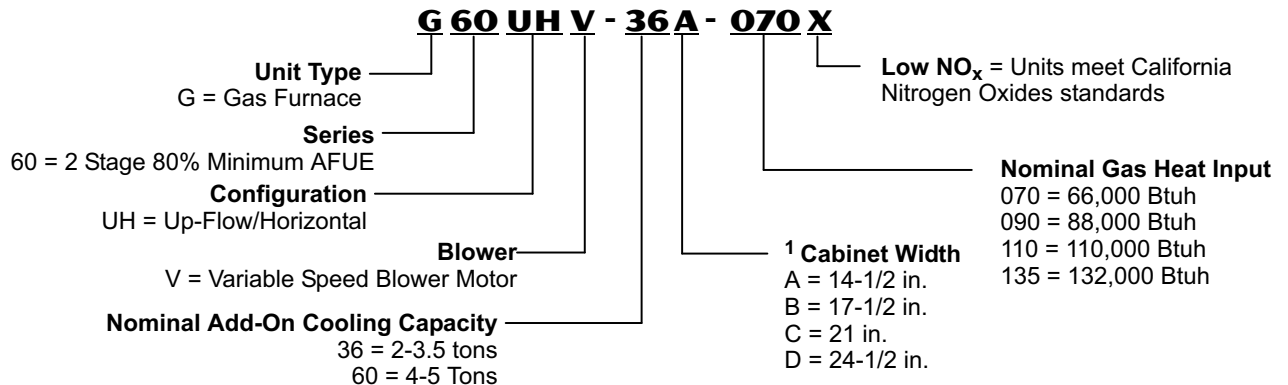

¹ Indoor coils with the same letter designation will physically match the furnace.

FEATURES

CONTENTS

Blower Data	Pages 11-21
Dimensions	Pages 7-10
Features and Options	Pages 2-4
Installation Clearances	Page 5
Model Number Identification	Page 1
Optional Accessories Selection Table	Page 6
Specifications	Page 6
Winter Design Temperature Map	Page 5

WARRANTY

Duralok™ Aluminized Steel Heat Exchanger - **Twenty years** limited warranty.

All other covered components - Five years limited warranty in residential applications, one year in non-residential applications.

Refer to Lennox Equipment Limited Warranty certificate included with equipment for details.

APPROVALS

Units are design certified by CSA International and ratings are certified by GAMA.

Units tested and rated according to US DOE test procedures and FTC labeling regulations.

Approved by California Energy Commission and meet California Seasonal Efficiency requirements and California Nitrogen Oxides (NO_x) Standards.

“X” models meet California Nitrogen Oxides (NO_x) Standards.

Blower data from unit tests conducted in Lennox Laboratory air test chamber.

ISO 9001 Registered Manufacturing Quality System.

APPLICATIONS

Input capacities of 66,000, 88,000, 110,000 and 132,000 Btuh.

Energy efficiency (AFUE) of 80.0%.

Utility room, alcove, closet, crawl space or attic installation.

Lennox add-on evaporator coils, high-efficiency air cleaners and humidifiers can easily be added to furnace. Shipped factory assembled with all controls installed and wired.

Ready for installation in up-flow or horizontal left or right hand position without any modifications. Removeable bottom seal panel shipped in place for side return air is easily removed for bottom/end return air applications.

Each unit factory test operated to ensure proper operation.

Zoning Applications

Units may be used with certain zoning systems. Zone control panel must be able to interface and communicate with the variable speed blower motor in the unit. Lennox Harmony III™ Zone Control Panel has this capability.

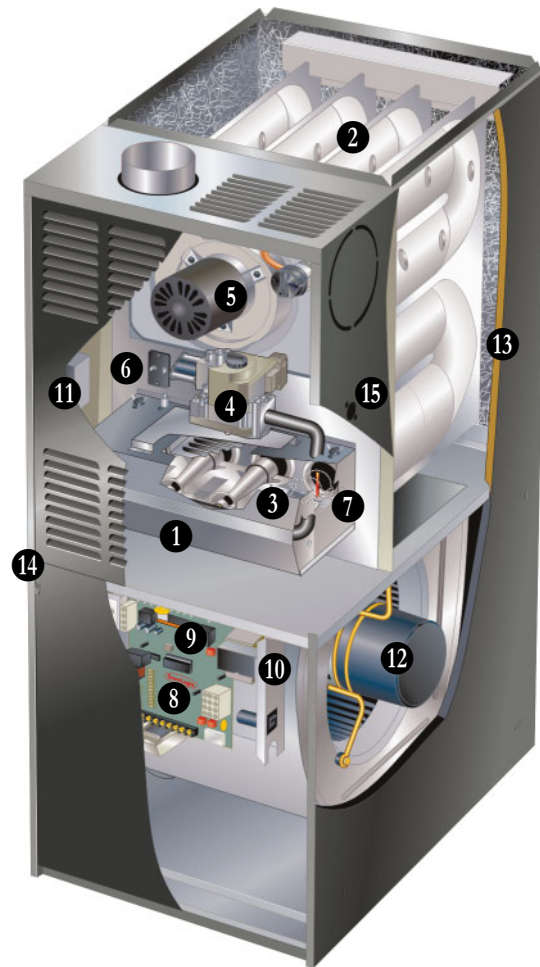

HEATING SYSTEM

- 1 SilentComfort™ Technology**
Patent pending burner sound enclosure and extra cabinet insulation reduces operating sound levels.
- 2 Lennox Duralok™ Aluminized Steel Heat Exchanger**
Heavy gauge aluminized steel heat exchanger.
Crimped seam clamshell type design.
Designed for normal expansion and contraction.
Minimum resistance to air flow.
Heat exchanger has been laboratory life cycle tested.
- 3 Inshot Burners**
Aluminized steel inshot burners provide efficient, trouble-free operation.
Burner venturi mixes air and gas in correct proportion for proper combustion.
Burner box assembly is removeable from the unit as a single component for ease of service.
Patent pending sound enclosure reduces operating sound levels.
- 4 Two Stage Gas Control Valve**
24 volt redundant combination two stage gas control valve combines manual shut off valve (On-Off), automatic electric valve (dual) and gas pressure regulation into a compact combination control.

FEATURES

HEATING SYSTEM (CONTINUED)

- 5 Two-Speed Combustion Air Inducer**
Shaded pole heavy duty two-speed blower prepurges heat exchanger and safely vents flue products. Dual pressure switches (low fire/high fire) prove blower operation before allowing gas valve to open. Operates only during heating cycle. Direct access allows inducer assembly to be rotated 90° clockwise or counterclockwise to facilitate easy vent attachment in horizontal applications.

- 6 Limit Controls**
Automatic reset, primary and secondary limits are accurately located. Primary limit factory installed on vestibule panel on all units, secondary limit(s) factory installed on blower housing.

Flame Rollout Switches (2)

Manual reset.
Factory installed on burner box.
Switches provide protection from abnormal operating conditions.

- 7 SureLight® Hot Surface Ignitor**
Tough, reliable, long-life, trouble-free performance. Tungsten heater element sandwiched between two plates of silicon nitride. Cemented to steatite block for protection against current leakage. Ignition leads constructed of nickel plated copper enclosed in high temperature Teflon® insulation for dependable operation. No electrical noise.

OPTIONS

High Altitude Orifice Kit - natural gas models only

Required on all natural gas units for proper unit operation at altitudes from 7,500 to 10,000 ft. Proper orifice for LPG/Propane models is included with optional LPG/Propane Conversion Kit.

High Altitude Pressure Switch Kit

Required on most units for proper unit operation at altitudes above 4,500 ft.

LPG/Propane Conversion Kit

Required for field changeover from natural gas.

Natural Gas Conversion Kit

Required for field changeover from LPG/Propane to natural gas..

Vent Adaptor (Up-Flow Applications Only)

Allows venting through a masonry chimney without the need of a flue liner.

Manual reset temperature sensor protects against abnormal operating conditions. Sensor wiring may be routed from either side of adaptor.

Minimum winter design temperatures when used with G60UHV furnaces is -10°F for -70, -90, -135 models and +5°F for -110 models.

Refer to Winter Design Temperatures Map on page 7 for application information. Also refer to the installation instructions for detailed information.

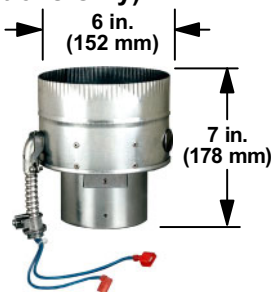

CONTROLS

- 8 SureLight® Integrated Two Stage / Variable Speed Blower Control**

Solid-state board contains all necessary controls and relays to operate furnace.

Combustion air inducer is controlled by board. Prior to ignition, a low speed pre-purge cycle for 15 seconds is initiated. After the main burners are turned off, a post-purge cycle for 5 seconds is run.

Adaptive technology of ignition control board continuously monitors and adjusts the ignitor power to operate at minimum ignitor temperature required for ignition, prolonging ignitor life.

Electronic flame sensor assures safe and reliable operation.

Should flame fail to ignite, flame sensor will initiate 4 re-attempts at ignition before locking out unit operation for 60 minutes.

Watchguard type circuit automatically resets ignition controls after one hour of continuous thermostat demand after unit lockout, eliminating nuisance calls for service. Jumper settings for single or two stage thermostat operation.

Two selectable second stage recognition times (10 and 15 minutes) are available on the board when the furnace is used with a single stage thermostat. When used with a two stage thermostat, furnace will only initiate second stage operation with a second stage thermostat demand.

Two LED's indicate heating status and aid in troubleshooting.

- 9** Two accessory terminals furnished for additional power supply requirements for 120 volt (less than 1 amp) power humidifiers and powered air cleaners.

Two blower speeds - second stage heat and second stage cool (with four air volume selections for each) are selected by DIP switches on board. Heat speed can be adjusted to optimize discharge temperature. Cool speed can be adjusted to correct optional cooling capacity. See Blower Performance tables.

First stage blower speed is a percentage of second stage speed.

The ADJUST switch (DIP) allows normal (NORM), 10% higher (+ plus) or 10% lower (— minus) motor speed selection within HEAT and COOL speeds selected for fine tuning air volume.

DELAY switch (DIP) allows one of four de-humidification profiles during cooling mode.

Profile A - Motor runs at 50% for 30 seconds, then at 82% for 7-1/2 minutes, then at 100% (if needed) until demand is satisfied. Once demand is met, motor runs at 50% for 30 seconds, then ramps down to stop.

Profile B - Motor runs at 82% for 7-1/2 minutes and then at 100% (if needed) until demand is satisfied. Once demand is met, motor ramps down to stop.

Profile C - Motor runs at 100% until demand is satisfied. Once demand is met, motor runs at 100% for 60 seconds, then ramps down to stop.

Profile D - Motor runs at 100% until demand is satisfied. Once demand is met, motor ramps down to stop.

FEATURES

CONTROLS CONTINUED

In heat mode, blower on time is fixed at 45 seconds, blower off time is adjustable from 60, 90, 120 and 180 seconds (factory setting - 90 seconds).

Control has four status lights (CFM, ON/OFF, HTG BLOWER, HI/LOW) to assist in servicing.

For air-conditioning applications, blower on time is 2 seconds following thermostat demand for cooling.

Board controls evaporator humidity by controlling blower and compressor speed on two stage outdoor units when used with humidity control or Lennox SignatureStat.

10 24 Volt Transformer

Furnished and factory installed in control box.

40VA transformer has circuit breaker wired in series.

Note - 50VA transformer is required when unit is used with Harmony Zone Control System. Ordered separately. See Price Book.

11 Field Wiring Make-up Box

Furnished for line voltage wiring.

Factory installed internally on left side of furnace.

Box may be installed internally or externally on either side of furnace.

OPTIONS

SignatureStat™ Home Comfort Control

Combination temperature and humidity control.

2 Heat/2 Cool

Auto-changeover

Controls humidity during cooling operation.

Easy-to-use, menu driven thermostat with a back-lit, dot-matrix LCD screen.

Remote outdoor sensor (furnished) allows the thermostat to display outdoor temperature and adjust indoor dewpoint temperature for precision humidity control in cooling mode.

See the SignatureStat Engineering Handbook bulletin in the Controls section for more information.



Thermostat

See Thermostat bulletins in Controls section and Lennox Price Book for a complete list of thermostats.

BLOWER

Variable Speed Direct Drive Blower

Each blower assembly statically and dynamically balanced.

Change in blower speed is easily accomplished by simple DIP switch change on SureLight® Integrated Furnace Two Stage / Variable Speed Blower Control.

See Blower Performance tables.

Blower assembly easily removed for servicing.

12 Variable Speed Blower Motor

Variable speed motor maintains specified air volume from 0 though 0.80 in. w.g. (0 through 200 Pa) static range.

Motor is controlled by SureLight® Integrated Furnace Two Stage / Variable Speed Blower Control.

Motor is resiliently mounted.

When furnaces are used with Harmony Zone Control System, blower motor operates from predetermined minimum - maximum air volumes to satisfy zone requirements.

G60UHV / Page 4

CABINET

- 13 Low profile, narrow width cabinet allows easy installation. Fully insulated cabinet with thick foil faced insulation (3 times thicker than standard furnace) on sides and back of heating compartment and special mat faced insulation in blower compartment (2 times thicker than standard furnace) to reduce operating sound levels.

Heavy gauge cold rolled steel constructed.

Pre-painted cabinet finish.

Flue outlet on top of cabinet for up-flow applications, can be relocated to either side of cabinet for horizontal applications.

Flanges provided on supply air opening for ease of plenum connection or alignment with evaporator coil.

Return Air Entry:

Bottom/end entry for up-flow/horizontal applications - remove furnished bottom seal panel from cabinet.

Side return air entry for up-flow applications - corners are marked on either side of cabinet for return air cut-outs.

See dimension drawings.

NOTE - 60C and 60D size units that require second stage air volumes over 1800 cfm must have one of the following:

1. Single side return air with transition, to accommodate 20 x 25 x 1 in. cleanable air filter. Required to maintain proper air velocity.
2. Single side return air with optional RAB Return Air Base
3. Bottom return air.
4. Return air from both sides.
5. Bottom and one side return air.

See Blower Performance Tables for additional information.

- 14 Complete service access.

Safety interlock switch automatically shuts off power to unit when blower compartment access door is removed.

- 15 Gas piping and electrical inlets are provided in both sides of cabinet.

Coil Match-Up

All furnaces exactly match C33 and CX34 cased up-flow and CH33 cased horizontal indoor coils with same letter designation in model no. No adaptor required. Engaging holes furnished on cabinet for alignment. See dimension drawings.

C33 uncased coils match furnaces without any overhang but require an optional adaptor base or field fabricated transition to match furnace opening. See C33 coil bulletin for additional information.

OPTIONS

Horizontal Support Frame Kit

Provides support of unit in horizontal applications.

Consists of (2) 1 x 1-1/2 x 32-5/8 in. and (2) 1 x 3 x 53-7/8 in. painted heavy gauge cold rolled steel support channels with assembly and suspending holes.

Bolts and nuts furnished for field assembly.

Suspending rods must be field provided.

RAB Return Air Base

“C” and “D” width bases required with 60C and 60D models with air volumes over 1800 cfm in up-flow applications when only one side return is used.

“B” width base is not required but may also be used to provide clearance in certain applications (if required).

Cabinet is pre-painted steel to match the furnace.

See Dimension Drawing.

FEATURES

FILTER (NOT FURNISHED)

Filter and provisions for external mounting must be field provided.

OPTIONS

Air Filter and Rack Kit for Horizontal Return Air (End) Applications

Washable or vacuum cleanable polyurethane frame type filter and external end return air rack available for field installation.

Rack has filter door for easy filter servicing.

Flanges on rack allow easy duct connection.

See dimension drawing.

Air Filter and Rack Kit for Up-Flow Side Return Air Applications - Not for use with RAB Return Air Base

Washable or vacuum cleanable polyurethane frame type filter and external side return air rack available for field installation.

Available in single and ten pack kits.

Rack has filter door for easy filter servicing.

Flanges on rack allow easy duct connection.

Field installs on either side of unit cabinet. See dimension drawing.

EZ Filter Base for Up-Flow Bottom Return Air Applications

Hinged door with thumbscrew for easy filter access.

Uses standard size filters (field provided).

99% WINTER DESIGN TEMPERATURES FOR THE CONTIGUOUS UNITED STATES



This map is a necessarily generalized guide to temperatures in the contiguous United States. Temperatures shown for areas such as mountainous regions and large urban centers may not be accurate.

The data used to develop this map was taken from the 1993 ASHRAE Fundamentals Handbook (Chapter 24, Table 1: Climate Conditions for the United States).

Reprinted with permission from NFPA 54: *National Fuel Gas Code* ©1999, National Fire Protection Association, Quincy, MA 02269. This reprinted material is not the complete and official position of the National Fire Protection Association on the referenced subject, which is represented only by the standard in its entirety.

INSTALLATION CLEARANCES - INCHES (MM)

UP-FLOW POSITION

Vent Type	Type "B1"	Type "C"
Sides	0 (0)	¹ 0 (0)
Rear	0 (0)	0 (0)
Top	1 (25)	1 (25)
Front	3 (76)	3 (76)
Front (service/alcove)	24 (610)	24 (610)
Floor	Combustible	Combustible
Flue	1 (25)	6 (152)

NOTE—Air for combustion and supply air ventilation must conform to the methods outlined in American National Standard (ANSI-Z223.1) National Fuel Gas Code or National Standard of Canada CAN/CGA-149.1, & CAN/CGA-149.2 "Installation Code for Gas Burning Appliances".

NOTE—In the U.S. flue sizing must conform to the methods outlined in current GAMA/A.G.A. venting tables, American National Standard (ANSI-Z223.1) National Fuel Gas Code or applicable provisions of local building codes. In Canada flue sizing must conform to the methods outlined in National Standard of Canada CAN/CGA-149.1 and .2.

¹ Left side requires 4 in. if single wall vent is used on 14-1/2 in. cabinets, 2 in. on 17-1/2 in. cabinets.

HORIZONTAL POSITION

Vent Type	Type "B1"	Type "C"
Ends	¹ 2	¹ 2
Rear	0 (0)	0 (0)
Top	¹ 0 (0)	¹ 0 (0)
Front	3 (76)	3 (76)
Front (service)	24 (610)	24 (610)
Floor	0 (0)	0 (0)
Flue	1 (25)	6 (152)

NOTE—Air for combustion and supply air ventilation must conform to the methods outlined in American National Standard (ANSI-Z223.1) National Fuel Gas Code or National Standard of Canada CAN/CGA-149.1, & CAN/CGA-149.2 "Installation Code for Gas Burning Appliances".

NOTE—In the U.S. flue sizing must conform to the methods outlined in current GAMA/A.G.A. venting tables, American National Standard (ANSI-Z223.1) National Fuel Gas Code or applicable provisions of local building codes. In Canada flue sizing must conform to the methods outlined in National Standard of Canada CAN/CGA-149.1 and .2.

¹ Line contact installation permissible between jacket top or sides and building joists.

SPECIFICATIONS

Gas Heating Performance	Model No.	G60UHV -36A-070	G60UHV -36B-090	G60UHV -60C-090	G60UHV -60C-110	G60UHV -60D-135
	Low NOx Model No.	G60UHV -36A-070X	- - -	G60UHV -60C-090X	G60UHV -60C-110X	- - -
Low Fire	Input - Btuh	45,000	60,000	60,000	75,000	90,000
	Output - Btuh	36,000	48,000	48,000	60,000	72,000
	Temperature rise range - °F	20 - 50	20 - 50	15 - 45	25 - 55	25 - 55
	Gas Manifold Pressure (in. w.g.) - Natural Gas / LPG/Propane	1.7 / 4.9	1.7 / 4.9	1.7 / 4.9	1.7 / 4.9	1.7 / 4.9
	High Fire	Input - Btuh	66,000	88,000	88,000	110,000
	Output - Btuh	54,000	72,000	72,000	90,000	108,000
	Temperature rise range - °F	40 - 70	40 - 70	30 - 60	35 - 65	45 - 75
	Gas Manifold Pressure (in. w.g.) - Natural Gas / LPG/Propane	3.5 / 10.0	3.5 / 10.0	3.5 / 10.0	3.5 / 10.0	3.5 / 10.0
	¹ AFUE	80.0%	80.0%	80.0%	80.0%	80.0%
	High static (CSA) - in. w.g.	.80	.80	.80	.80	.80
Connections	Flue connection - in. round	4	4	4	4	² 4
	Gas pipe size IPS - in.	1/2	1/2	1/2	1/2	1/2
Blower Data	Wheel nominal diameter x width - in.	10 x 8	10 x 8	11-1/2 x 10	11-1/2 x 10	11-1/2 x 10
	Motor output - hp	1/2	1/2	1	1	1
	Tons of add-on cooling	2 - 3	2 - 3.5	3.5 - 5	3.5 - 5	4 - 5
	Air Volume Range - cfm	630 - 1380	625 - 1385	930 - 2255	900 - 2185	900 - 2140
Shipping Data - lbs. 1 Package		137	154	172	184	198
Electrical characteristics		120 volts - 60 hertz - 1 phase (less than 12 amps)				

NOTE - Filters and provisions for mounting are not furnished and must be field provided.

¹ Annual Fuel Utilization Efficiency based on DOE test procedures and according to FTC labeling regulations. Isolated combustion system rating for non-weatherized furnaces.

² Flue connection on the unit is 4 in. diameter. Most applications will require 5 in. venting and field supplied 4 x 5 in. adaptor. See Venting Tables in the Installation Instructions for detailed information.

OPTIONAL ACCESSORIES - MUST BE ORDERED EXTRA

			"A" Width Models	"B" Width Models	"C" Width Models	"D" Width Models
FILTER KITS						
¹ Air Filter and Rack Kit	Horizontal (end)	Catalog No.	87L95	87L96	87L97	87L98
		Size of filter - in.	14 x 25 x 1	18 x 25 x 1	20 x 25 x 1	25x25 x 1
	Side Return	Single	44J22	44J22	44J22	44J22
		Ten Pack	66K63	66K63	66K63	66K63
		Size of filter - in.	16 x 25 x 1	16 x 25 x 1	16 x 25 x 1	16 x 25 x 1
EZ Filter Base Up-Flow Only		Catalog No. - Ship. Wt. - lbs.	73P55 - 7	73P56 - 7	73P57 - 8	73P58 - 10
		Size of field provided filter - in.	14 x 25 x 1	16 x 25 x 1	20 x 25 x 1	24 x 24 x 1
CABINET ACCESSORIES						
Down-Flow Additive Base - Down-Flow Only			11M60	11M60	11M61	11M62
Horizontal Support Frame Kit - Horizontal Only			56J18	56J18	56J18	56J18
Return Air Base - Up-Flow Only			- - -	98M60	98M58	98M59
CONTROLS						
SignatureStat™ Home Comfort Control			81M27	81M27	81M27	81M27
VENTING						
Vent Adaptor - 6 in. conn. size up-flow applications only			18M79 - 2 lbs.	18M79 - 2 lbs.	18M79 - 2 lbs.	18M79 - 2 lbs.

¹ Cleanable polyurethane, frame-type filter

GAS HEAT ACCESSORIES

Input	High Altitude Orifice Kit Natural Gas	High Altitude Pressure Switch Kit - Order two each		LPG/Propane Kit		LPG/Propane to Natural Gas Kit	
	7501-10,000 ft.	4501-7500 ft.	7501-10,000 ft.	0-7500 ft.	7501-10,000 ft.	0-7500 ft.	7501-10,000 ft.
-070	59M17	- - -	18M64	59M13	59M14	59M87	59M87 + 59M17
-090	59M17	18M61	18M64	59M13	59M14	59M87	59M87 + 59M17
-110 -135	59M17	18M63	18M61	59M13	59M14	59M87	59M87 + 59M17

DIMENSIONS - INCHES (MM) - UP-FLOW POSITION

¹ NOTE - 60C and 60D size units that require second stage air volumes over 1800 cfm (850 L/s) must have one of the following:

1. Single side return air with transition, to accommodate 20 x 25 x 1 in. (508 x 635 x 25 mm) cleanable air filter. Required to maintain proper air velocity.
 2. Single side return air with optional RAB Return Air Base
 3. Bottom return air.
 4. Return air from both sides.
 5. Bottom and one side return air.
- See Blower Performance Tables for additional information.

² Flue outlet may be horizontal but furnace must be vented vertically

³ Optional External Side Return Air Filter Kit is not for use with the optional RAB Return Air Base.

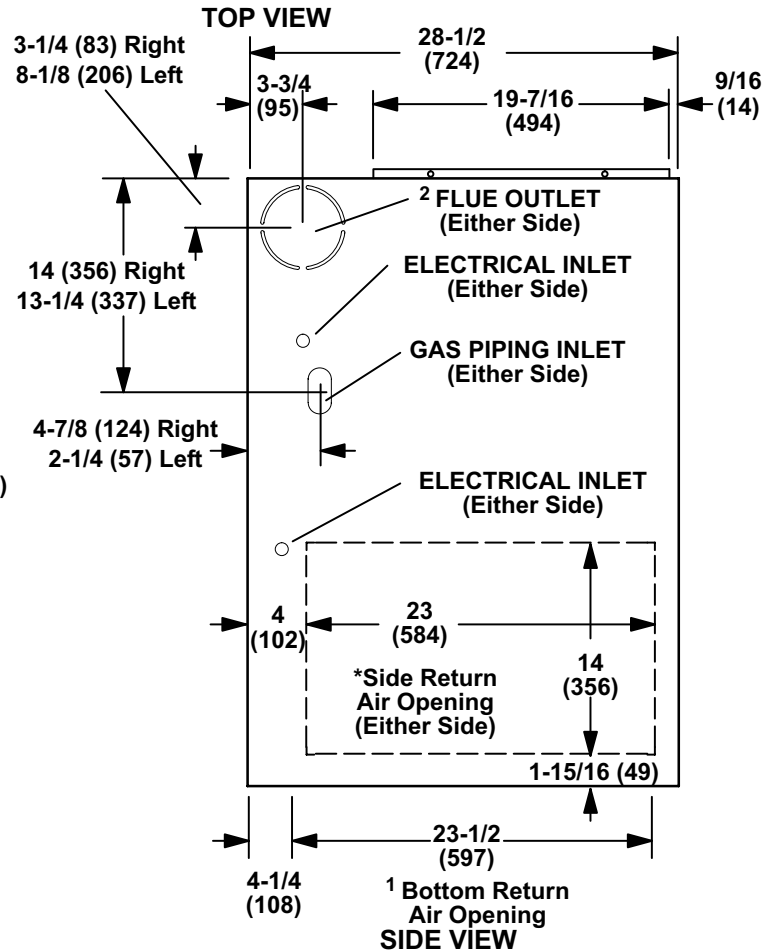
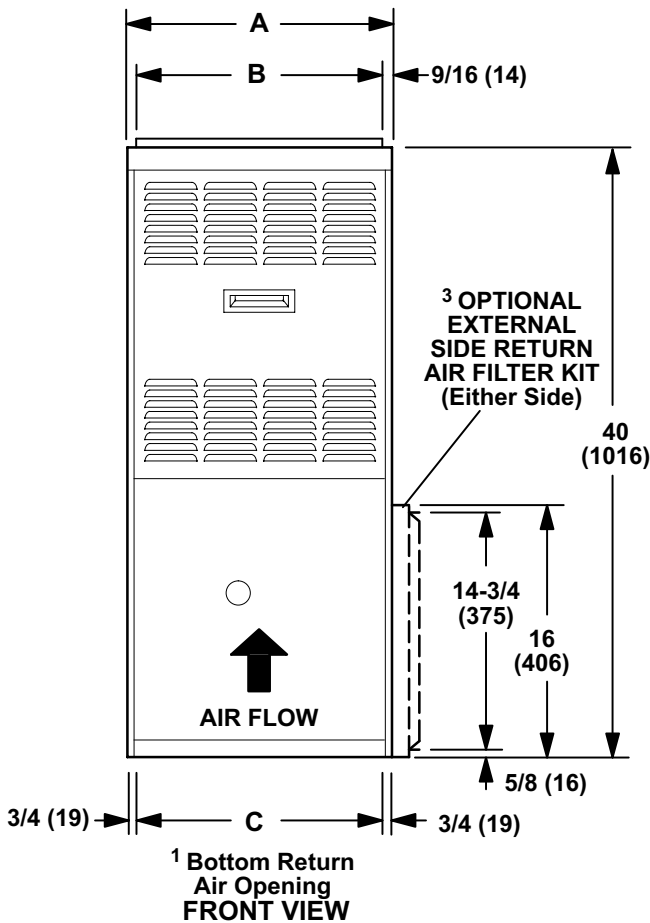
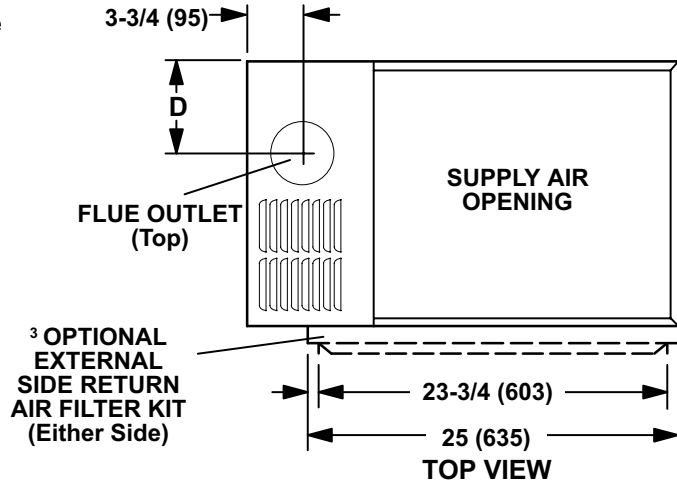

Model No.	A		B		C		D	
	in.	mm	in.	mm	in.	mm	in.	mm
G60UHV-36A-070	14-1/2	368	13-3/8	340	13	330	4-1/2	114
G60UHV-36B-090	17-1/2	446	16-3/8	416	16	406	6	152
G60UHV-60C-90 G60UHV-60C-110	21	533	19-7/8	504	19-1/2	495	7-3/4	197
G60UHV-60D-135	24-1/2	622	23-3/8	546	23	584	9-1/2	241

DIMENSIONS - INCHES (MM) - HORIZONTAL POSITION

LEFT-HAND AIR DISCHARGE

¹ Flue outlet may be from end but furnace must be vented vertically

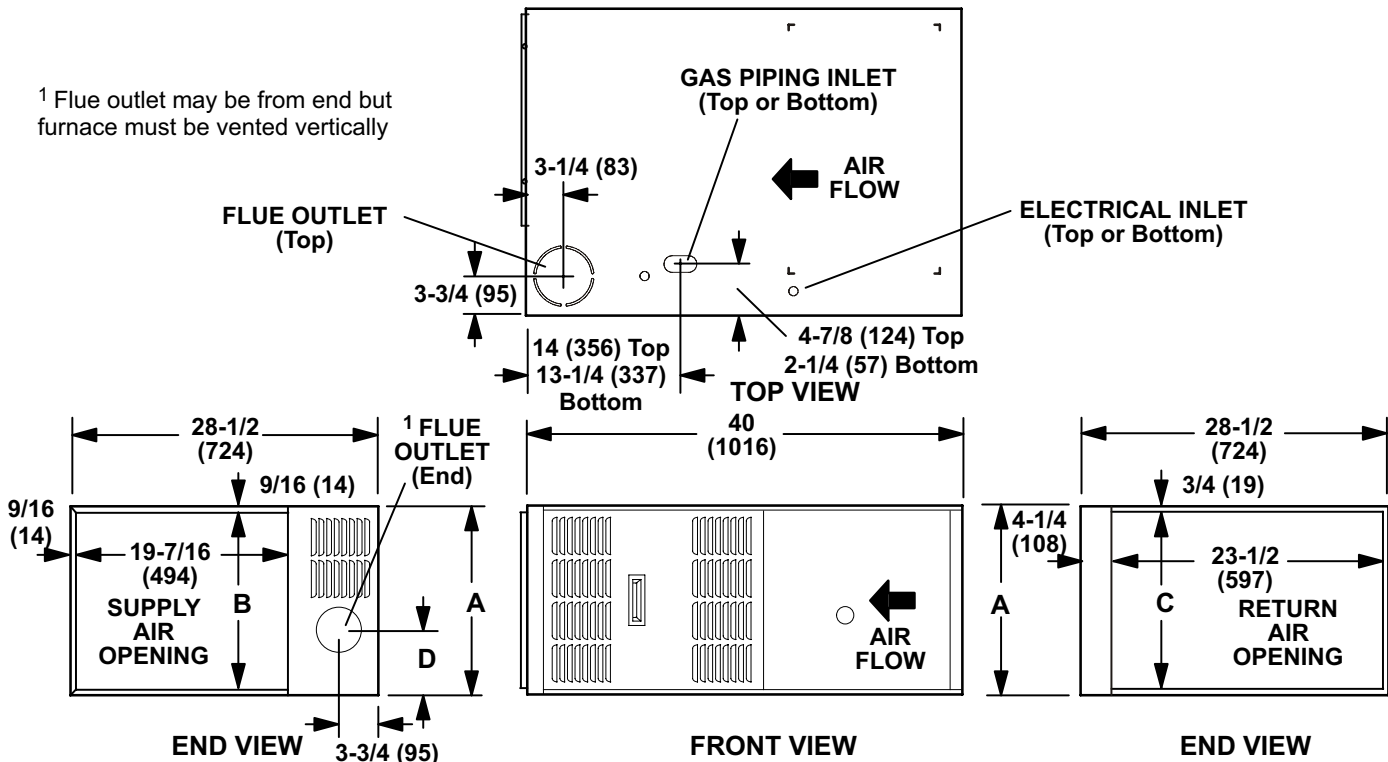

RIGHT-HAND AIR DISCHARGE

¹ Flue outlet may be horizontal but furnace must be vented vertically

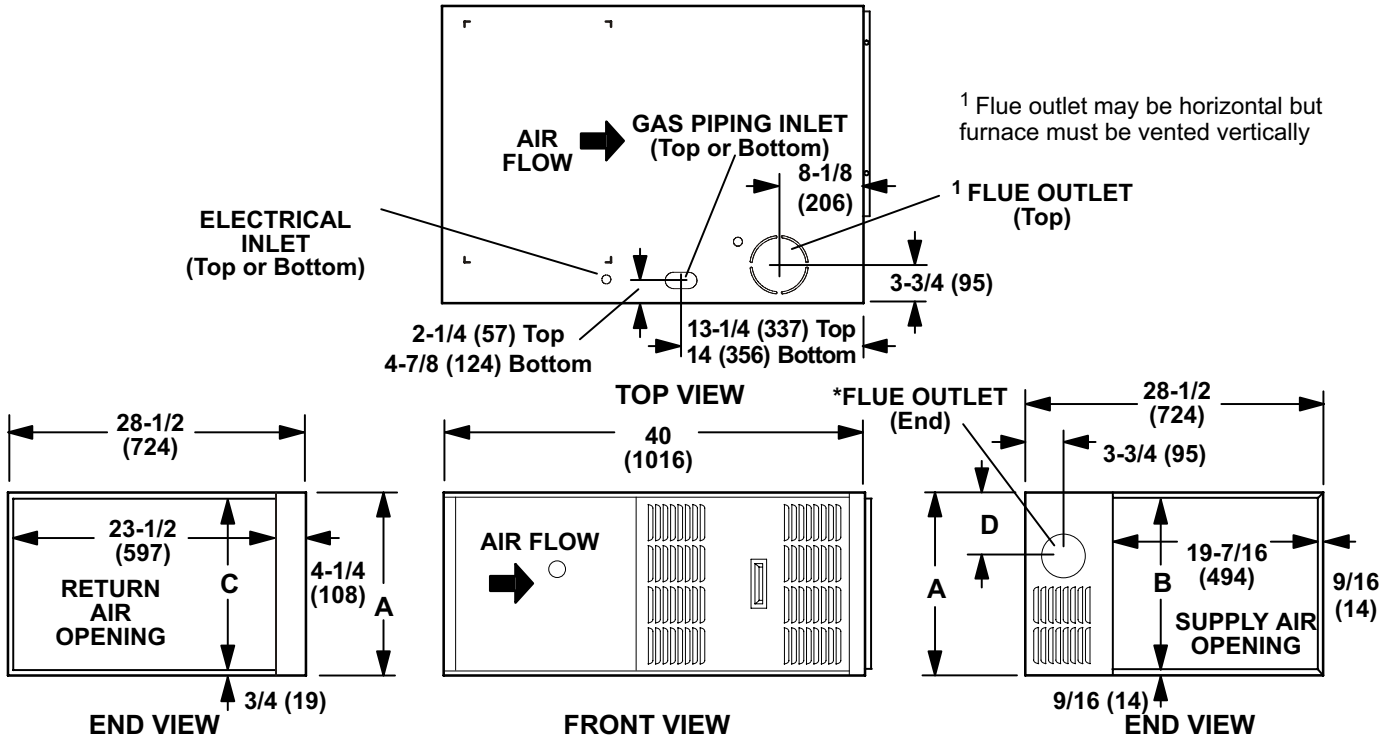

Model No.	A		B		C		D	
	in.	mm	in.	mm	in.	mm	in.	mm
G60UHV-36A-070	14-1/2	368	13-3/8	340	13	330	4-1/2	114
G60UHV-36B-090	17-1/2	446	16-3/8	416	16	406	6	152
G60UHV-60C-90 G60UHV-60C-110	21	533	19-7/8	454	19-1/2	495	7-3/4	197
G60UHV-60D-135	24-1/2	622	23-3/8	546	23	584	9-1/2	241

OPTIONAL ACCESSORY DIMENSIONS - INCHES (MM)

HORIZONTAL FILTER KIT

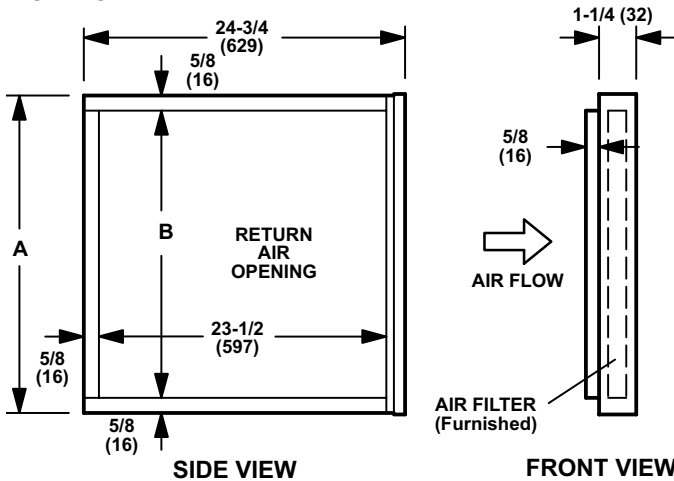

Catalog Number	A		B	
	inch	mm	inch	mm
89L95	14	356	12-3/4	324
89L96	18	457	16-3/4	425
89L97	21	533	18-3/4	476
89L98	25	635	23-3/4	603

RAB RETURN AIR BASE (Up-Flow Applications Only) For use with B, C, and D size furnaces only

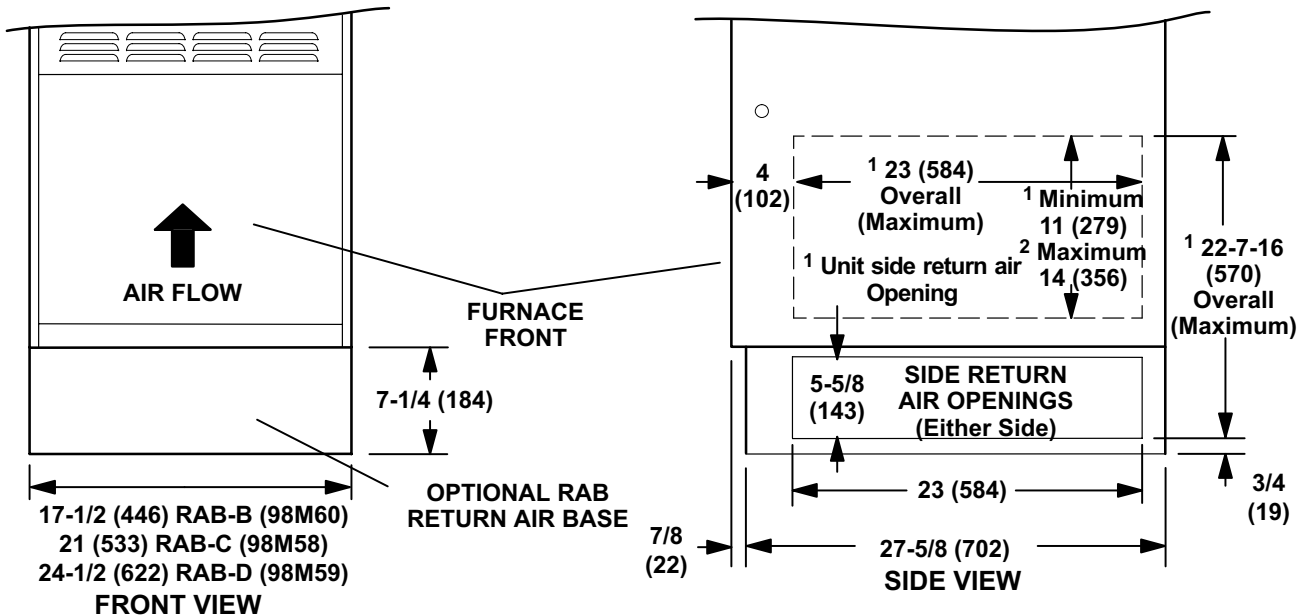

17-1/2 (446) RAB-B (98M60)
21 (533) RAB-C (98M58)
24-1/2 (622) RAB-D (98M59)

FRONT VIEW

SIDE VIEW

NOTE- Optional Side Return Air Filter Kits are not for use with RAB Return Air Base.

¹ Both the unit return air opening and the base return air opening must be covered by a single plenum or IAQ cabinet.

Minimum unit side return air opening dimensions for units requiring 1800 cfm or more of air (W x H): 23 x 11 in. (584 x 279 mm).

The opening can be cut as needed to accommodate plenum or IAQ cabinet while maintaining dimensions shown.

Side return air openings must be cut in the field. There are cutting guides stenciled on the cabinet for the side return air opening. The size of the opening must not extend beyond the markings on the furnace cabinet.

² To minimize pressure drop, the largest opening height possible (up to 14 inches) is preferred.

NOTE- Optional Side Return Air Filter Kits are not for use with RAB Return Air Base.

DIMENSIONS - INCHES (MM) - FURNACE/COIL COMBINED DIMENSIONS

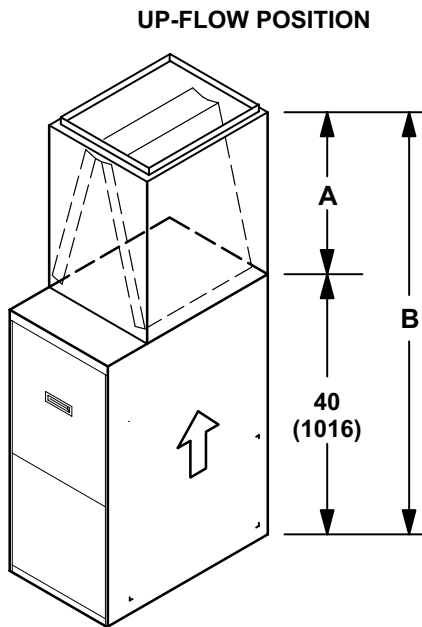

Model No	Cased				Uncased (CX34 - cased only)				
	A		B		A		B		
	in.	mm	in.	mm	in.	mm	in.	mm	
C33-18A	12-1/2	318	52-1/2	1334	9-3/4	248	49-3/4	1264	
CX34-19A-6F	C33-19A	17-1/2	445	57-1/2	1461	9-3/4	248	49-3/4	1264
C33-24A	16-1/2	419	56-1/2	1435	14	356	54	1372	
CX34-18/24A-6F	C33-24B	16-1/2	419	56-1/2	1435	13-7/8	352	53-7/8	1368
CX34-18/24B-6F	C33-24C								
CX34-18/24C-6F									
CX34-25A-6F	C33-25A	19-1/2	495	59-1/2	1511	16-1/4	413	56-1/4	1429
CX34-25B-6F	C33-25B	19-1/2	495	59-1/2	1511	15-7/8	403	55-7/8	1419
CX34-30B-6F	C33-30B	20-1/2	521	60-1/2	1537	17-3/4	451	59-3/4	1467
CX34-30C-6F	C33-30C								
CX34-30A-6F	C33-30A	20-1/2	521	60-1/2	1537	18	457	58	1473
CX34-31A-6F	C33-31A	23-1/2	597	63-1/2	1613	21-1/4	540	61-1/4	1556
CX34-31B-6F	C33-31B	23-1/2	597	63-1/2	1613	20-1/4	514	60-1/4	1530
CX34-36A-6F	C33-36A	24-1/2	622	64-1/2	1638	22-1/8	562	62-1/8	1578
CX34-36B-6F	C33-36B	24-1/2	622	64-1/2	1638	21-7/8	556	61-7/8	1572
CX34-36C-6F	C33-36C	24-1/2	622	64-1/2	1638	21-1/4	540	61-1/4	1556
CX34-38A-6F	C33-38A	24-1/2	622	64-1/2	1638	22-1/4	565	62-1/4	1581
CX34-38B-6F	C33-38B	24-1/2	622	64-1/2	1638	22	559	62	1575
CX34-42B-6F	C33-42B	24-1/2	622	64-1/2	1638	21-7/8	556	61-7/8	1572
CX34-43B-6F	C33-43B	28-1/2	724	68-1/2	1740	26-1/4	667	66-1/4	1683
CX34-43C-6F	C33-43C	28-1/2	724	68-1/2	1740	25-3/4	654	65-3/4	1670
C33-44C		24-1/2	622	64-1/2	1638	21-1/2	546	61-1/2	1562
CX34-44/48B-6F	C33-48B	24-1/2	622	64-1/2	1638	22-1/8	562	62-1/8	1578
CX34-44/48C-6F	C33-48C	24-1/2	622	64-1/2	1638	21-1/2	546	61-1/2	1562
CX34-49C-6F	C33-49C	30-1/2	775	70-1/2	1791	28-1/2	724	68-1/2	1740
CX34-50/60C-6F	C33-50/60C	27-1/2	699	67-1/2	1715	24-3/4	629	64-3/4	1645
CX34-60D-6F	C33-60D	25-1/2	648	65-1/2	1664	24-3/4	629	64-3/4	1645
CX34-62C-6F	C33-62C	32-1/2	826	72-1/2	1842	30-5/8	778	70-5/8	1793
CX34-62D-6F	C33-62D	29-1/2	749	69-1/2	1765	28-3/4	730	68-3/4	1746

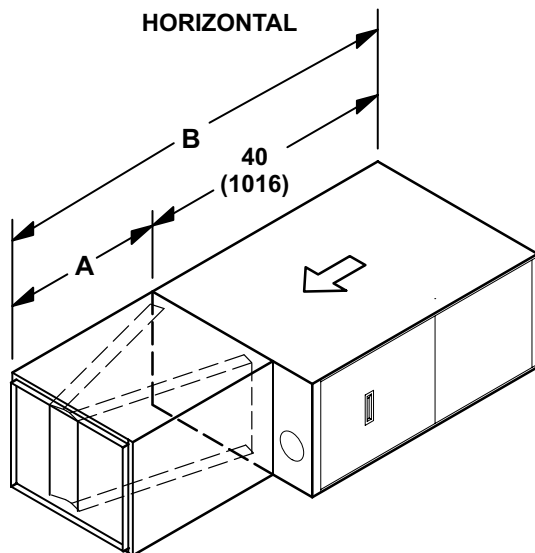

Model Number	A		B	
	in.	mm	in.	mm
CH33-18A-2F	21-1/2	546	61-1/2	1562
CH33-24/30A-2F	26-1/2	673	66-1/2	1689
CH33-36A-2F				
CH33-36B-2F				
CH33-36C-2F				
CH33-44/48B-2F	31-1/2	800	71-1/2	1816
CH33-50/60C-2F				
CH33-42B-2F				
CH33-48C-2F				
CH33-60D-2F				
CH33-62D-2F				

BLOWER DATA

G60UHV-36A-070 BLOWER PERFORMANCE (less filter) 0 through 0.80 in. w.g. External Static Pressure Range

"ADJUST" Switch Positions	Speed Switch Positions							
	Second Stage "HEAT" Speed - cfm				Second Stage "COOL" Speed - cfm			
	1	1 2	3	4	1	2	3	1 4
+	895	1015	1275	1320	1000	1165	1260	1380
¹ NORM	815	925	1120	1170	915	1035	1115	1230
—	740	845	1000	1040	830	945	990	1085
"ADJUST" Switch Positions	First Stage "HEAT" Speed - cfm				First Stage "COOL" Speed - cfm			
	1	1 2	3	4	1	2	3	1 4
	+	820	930	1140	1195	730	810	865
¹ NORM	755	855	1020	1060	670	745	785	850
—	695	775	920	965	630	690	725	770

¹ Factory default jumper setting.

NOTES - The effect of static pressure is included in air volumes shown.

First stage HEAT is approximately **91%** of the same second stage HEAT speed position.

First stage COOL (two-stage air conditioning units only) is approximately **70%** of the same second stage COOL speed position.

Continuous Fan Only speed is approximately **38%** of the same second stage COOL speed position - minimum 500 cfm.

Lennox Harmony III™ Zone Control Applications - Minimum blower speed is 426 cfm.

G60UHV-36A-070 BLOWER MOTOR WATTS

Jumper Speed Positions	Motor Watts @ Various External Static Pressures - in. wg.																		
	First Stage									Second Stage									
	0	0.1	0.2	0.3	0.4	0.5	0.6	0.7	0.8	0	0.1	0.2	0.3	0.4	0.5	0.6	0.7	0.8	
"+" (Plus) SETTING ("Adjust" Jumper at "+" Setting)																			
"HEAT" Speed	Tap 1	65	85	105	125	140	160	180	205	225	85	95	120	140	160	180	205	225	250
	Tap 2	90	110	135	160	185	205	230	250	270	105	130	160	190	210	230	255	280	305
	Tap 3	150	175	210	240	270	295	320	345	370	200	230	265	300	330	360	385	415	440
	Tap 4	165	195	225	260	295	325	350	375	400	235	265	300	335	365	395	420	450	480
"COOL" Speed	Tap 1	50	65	85	100	120	135	155	170	190	100	125	155	180	205	225	250	270	295
	Tap 2	65	80	100	120	135	155	180	200	225	140	170	210	250	280	305	335	360	390
	Tap 3	80	95	115	135	155	175	195	215	235	170	205	250	295	330	360	385	410	440
	Tap 4	80	100	125	150	175	195	215	240	260	265	295	330	365	400	430	465	500	535
"NORM" (Normal) SETTING ("Adjust" Jumper at "NORM" Setting)																			
"HEAT" Speed	Tap 1	55	70	90	105	125	140	160	180	200	70	85	100	120	140	160	185	205	230
	Tap 2	70	90	110	130	155	180	200	215	235	85	105	130	155	180	200	225	245	265
	Tap 3	120	135	155	180	210	240	260	285	305	140	165	195	225	255	285	310	335	360
	Tap 4	120	140	170	200	230	260	285	310	340	150	180	215	250	285	320	345	365	390
"COOL" Speed	Tap 1	45	60	75	90	105	125	140	155	175	75	100	125	155	175	195	215	235	255
	Tap 2	50	65	85	105	125	140	160	175	195	120	140	165	185	220	250	275	300	320
	Tap 3	60	75	95	115	135	150	175	195	220	130	160	195	230	255	280	305	335	365
	Tap 4	70	90	110	130	150	170	195	215	240	185	215	245	275	310	345	370	400	425
"-" (Minus) SETTING ("Adjust" Jumper at "-" Setting)																			
"HEAT" Speed	Tap 1	50	65	80	95	115	130	145	160	175	55	70	90	110	120	135	155	170	190
	Tap 2	65	75	95	110	130	150	170	190	205	75	90	105	125	150	170	195	215	240
	Tap 3	80	100	125	155	175	195	215	240	260	110	130	155	180	205	230	255	285	310
	Tap 4	100	120	140	160	190	215	235	255	270	120	140	165	190	215	240	265	295	320
"COOL" Speed	Tap 1	40	55	65	80	95	110	130	145	160	75	90	110	130	150	170	190	205	225
	Tap 2	45	60	75	95	110	130	145	160	175	95	110	135	155	180	205	225	245	265
	Tap 3	50	65	85	100	120	135	155	170	190	100	125	150	175	200	220	245	275	300
	Tap 4	55	70	90	110	135	155	170	190	210	115	145	180	215	240	265	290	315	345

BLOWER DATA

G60UHV-36B-090 BLOWER PERFORMANCE (less filter) 0 through 0.80 in. w.g. External Static Pressure Range

"ADJUST" Switch Positions	Speed Switch Positions							
	Second Stage "HEAT" Speed - cfm				Second Stage "COOL" Speed - cfm			
	1	1 2	3	4	1	2	3	1 4
+	N/A	1025	1265	1320	1005	1165	1260	1385
¹ NORM	N/A	N/A	1125	1170	905	1035	1110	1225
—	N/A	N/A	1010	1045	825	940	1000	1090
"ADJUST" Switch Positions	First Stage "HEAT" Speed - cfm				First Stage "COOL" Speed - cfm			
	1	1 2	3	4	1	2	3	1 4
	+	N/A	940	1140	1185	725	810	860
¹ NORM	N/A	N/A	1030	1065	670	740	785	840
—	N/A	N/A	925	950	625	695	725	770

¹ Factory default jumper setting.

N/A - First and second stage HEAT positions shown cannot be used on this model.

NOTES - The effect of static pressure is included in air volumes shown.

First stage HEAT is approximately **91%** of the same second stage HEAT speed position.

First stage COOL (two-stage air conditioning units only) is approximately **70%** of the same second stage COOL speed position.

Continuous Fan Only speed is approximately **38%** of the same second stage COOL speed position - minimum 500 cfm.

Lennox Harmony III™ Zone Control Applications - Minimum blower speed is 453 cfm.

G60UHV-36B-090 BLOWER MOTOR WATTS

Jumper Speed Positions	Motor Watts @ Various External Static Pressures - in. wg.																		
	First Stage									Second Stage									
	0	0.1	0.2	0.3	0.4	0.5	0.6	0.7	0.8	0	0.1	0.2	0.3	0.4	0.5	0.6	0.7	0.8	
"+" (Plus) SETTING ("Adjust" Jumper at "+" Setting)																			
"HEAT" Speed	Tap 1	N/A	N/A	N/A	N/A	N/A	N/A	N/A	N/A	N/A	N/A	N/A	N/A	N/A	N/A	N/A	N/A	N/A	N/A
	Tap 2	65	85	105	130	150	170	195	215	240	85	105	130	155	180	200	225	250	270
	Tap 3	105	130	160	190	220	250	280	305	330	140	170	205	240	270	300	330	355	385
	Tap 4	110	135	170	205	235	265	295	325	355	150	185	220	260	290	325	355	385	415
"COOL" Speed	Tap 1	35	50	70	90	105	125	140	155	170	75	95	125	150	175	195	220	240	265
	Tap 2	50	65	85	100	120	140	160	185	205	110	135	170	200	235	265	290	315	340
	Tap 3	55	70	90	105	130	150	170	195	220	140	165	200	230	265	295	325	350	380
	Tap 4	60	75	100	125	150	170	195	220	240	195	225	255	290	320	350	380	415	450
"NORM" (Normal) SETTING ("Adjust" Jumper at "NORM" Setting)																			
"HEAT" Speed	Tap 1	N/A	N/A	N/A	N/A	N/A	N/A	N/A	N/A	N/A	N/A	N/A	N/A	N/A	N/A	N/A	N/A	N/A	N/A
	Tap 2	N/A	N/A	N/A	N/A	N/A	N/A	N/A	N/A	N/A	N/A	N/A	N/A	N/A	N/A	N/A	N/A	N/A	N/A
	Tap 3	85	105	130	150	180	205	225	250	270	110	130	155	185	210	235	265	295	320
	Tap 4	90	110	140	165	185	210	235	265	290	110	135	165	195	225	255	285	315	340
"COOL" Speed	Tap 1	35	45	60	75	90	105	125	145	160	60	75	100	120	145	165	185	205	225
	Tap 2	35	50	70	90	105	120	140	165	185	85	105	135	160	185	205	235	260	290
	Tap 3	45	60	75	95	115	130	150	175	195	85	115	145	18	210	235	265	290	320
	Tap 4	50	65	85	105	125	140	165	185	210	120	150	180	215	250	285	315	345	370
"-" (Minus) SETTING ("Adjust" Jumper at "-" Setting)																			
"HEAT" Speed	Tap 1	N/A	N/A	N/A	N/A	N/A	N/A	N/A	N/A	N/A	N/A	N/A	N/A	N/A	N/A	N/A	N/A	N/A	N/A
	Tap 2	N/A	N/A	N/A	N/A	N/A	N/A	N/A	N/A	N/A	N/A	N/A	N/A	N/A	N/A	N/A	N/A	N/A	N/A
	Tap 3	60	75	100	125	145	170	190	215	235	75	95	120	150	170	195	220	245	265
	Tap 4	70	85	110	130	155	180	200	220	245	85	105	130	155	180	210	235	260	285
"COOL" Speed	Tap 1	30	40	55	70	90	105	120	135	150	45	60	85	105	125	140	160	180	200
	Tap 2	35	45	65	80	95	110	130	150	165	55	75	105	130	150	170	195	215	235
	Tap 3	40	50	70	90	105	125	140	155	175	75	95	120	150	170	195	215	240	265
	Tap 4	45	60	75	95	115	135	150	170	185	90	115	145	175	200	225	245	270	290

BLOWER DATA

G60UHV-60C-090 BLOWER PERFORMANCE (less filter)

Bottom Return Air, Return Air from Both Sides or Return Air from Bottom and One Side.

0 through 0.80 in. w.g. External Static Pressure Range

"ADJUST" Switch Positions	Speed Switch Positions							
	Second Stage "HEAT" Speed - cfm				Second Stage "COOL" Speed - cfm			
	1	1 2	3	4	1	2	3	1 4
+	1570	1770	1965	2185	1680	1795	2015	2255
¹ NORM	1425	1625	1810	1990	1520	1635	1855	2065
—	1270	1435	1635	1790	1355	1460	1670	1845

"ADJUST" Switch Positions	First Stage "HEAT" Speed - cfm				First Stage "COOL" Speed - cfm			
	1	1 2	3	4	1	2	3	1 4
	+	1430	1625	1815	1990	1170	1250	1425
¹ NORM	1290	1470	1660	1830	1060	1140	1280	1445
—	1165	1300	1470	1635	930	1015	1155	1285

¹ Factory default jumper setting.

NOTES - The effect of static pressure is included in air volumes shown.

First stage HEAT is approximately **91%** of the same second stage HEAT speed position.

First stage COOL (two-stage air conditioning units only) is approximately **70%** of the same second stage COOL speed position.

Continuous Fan Only speed is approximately **38%** of the same second stage COOL speed position - minimum 500 cfm.

Lennox Harmony III™ Zone Control Applications - Minimum blower speed is 478 cfm.

G60UHV-60C-090 BLOWER MOTOR WATTS

Jumper Speed Positions	Motor Watts @ Various External Static Pressures - in. wg.																		
	First Stage									Second Stage									
	0	0.1	0.2	0.3	0.4	0.5	0.6	0.7	0.8	0	0.1	0.2	0.3	0.4	0.5	0.6	0.7	0.8	
"+" (Plus) SETTING ("Adjust" Jumper at "+" Setting)																			
"HEAT" Speed	Tap 1	160	190	230	265	300	330	365	400	430	215	250	290	330	365	395	425	460	490
	Tap 2	235	270	315	360	395	430	465	495	530	330	365	405	440	480	515	545	570	600
	Tap 3	350	385	425	465	500	535	570	605	640	450	485	520	555	605	650	695	735	780
	Tap 4	455	495	540	585	625	670	710	755	795	580	635	690	745	800	855	890	930	970
"COOL" Speed	Tap 1	100	125	155	180	205	225	250	275	305	260	300	350	395	430	465	495	530	560
	Tap 2	125	150	175	200	225	250	275	300	325	345	380	415	450	490	525	560	595	630
	Tap 3	170	195	225	255	290	325	355	390	420	470	510	555	595	640	685	730	775	820
	Tap 4	215	250	295	335	370	410	445	475	510	665	720	780	840	880	920	965	1005	1045
"NORM" (Normal) SETTING ("Adjust" Jumper at "NORM" Setting)																			
"HEAT" Speed	Tap 1	140	160	185	210	240	270	295	320	345	155	190	230	270	300	330	365	400	430
	Tap 2	185	215	245	280	315	350	380	410	445	250	280	310	345	385	425	460	495	525
	Tap 3	260	295	335	375	410	450	475	505	530	335	375	420	465	500	530	570	610	645
	Tap 4	355	390	430	465	505	545	580	610	640	465	505	545	585	620	650	695	735	780
"COOL" Speed	Tap 1	75	95	120	145	170	200	220	245	265	190	230	270	315	345	375	410	440	475
	Tap 2	90	110	140	170	195	220	245	265	285	245	285	325	365	400	430	460	490	520
	Tap 3	135	155	185	215	240	265	290	315	340	360	400	450	495	530	570	600	630	660
	Tap 4	160	195	235	280	310	335	370	400	430	495	545	595	645	690	730	775	825	875
"-" (Minus) SETTING ("Adjust" Jumper at "-" Setting)																			
"HEAT" Speed	Tap 1	90	110	140	170	205	235	255	280	300	130	155	180	205	235	260	285	305	330
	Tap 2	145	165	190	215	250	280	310	335	365	165	195	230	265	300	335	365	400	430
	Tap 3	175	205	245	285	315	350	385	415	450	245	280	325	365	400	435	470	505	540
	Tap 4	255	290	325	360	400	440	470	505	535	335	370	410	450	485	520	560	595	635
"COOL" Speed	Tap 1	65	80	100	120	140	160	180	205	230	140	170	200	235	260	290	320	350	380
	Tap 2	70	90	115	135	160	180	200	220	245	165	200	240	280	310	345	375	405	435
	Tap 3	105	125	150	175	200	225	250	275	300	260	295	335	375	410	450	485	520	560
	Tap 4	135	155	185	215	245	270	300	325	350	370	410	450	490	515	545	585	625	660

BLOWER DATA

G60UHV-60C-090 BLOWER PERFORMANCE (less filter)

Single Side Return Air - Air volumes in bold require field fabricated transition to accommodate 20 x 25 x 1 in. cleanable air filter in order to maintain proper air velocity across the filter.

0 through 0.80 in. w.g. External Static Pressure Range

"ADJUST" Switch Positions	Speed Switch Positions							
	Second Stage "HEAT" Speed - cfm				Second Stage "COOL" Speed - cfm			
	1	1 2	3	4	1	2	3	1 4
+	1520	1705	1910	2120	1605	1745	1955	2195
	1380	1540	1750	1925	1475	1565	1785	1985
	1230	1395	1570	1745	1305	1410	1590	1795
"ADJUST" Switch Positions	First Stage "HEAT" Speed - cfm				First Stage "COOL" Speed - cfm			
	1	1 2	3	4	1	2	3	1 4
	1385	1560	1765	1945	1125	1210	1370	1525
1 NORM	1255	1425	1580	1785	1020	1100	1235	1385
	1135	1265	1430	1570	890	980	1115	1235

¹ Factory default jumper setting.

NOTES - The effect of static pressure is included in air volumes shown.

First stage HEAT is approximately **91%** of the same second stage HEAT speed position.

First stage COOL (two-stage air conditioning units only) is approximately **70%** of the same second stage COOL speed position.

Continuous Fan Only speed is approximately **38%** of the same second stage COOL speed position - minimum 500 cfm.

Lennox Harmony III™ Zone Control Applications - Minimum blower speed is 478 cfm.

G60UHV-60C-090 BLOWER MOTOR WATTS - Side Return

Jumper Speed Positions	Motor Watts @ Various External Static Pressures - in. wg.																		
	First Stage										Second Stage								
	0	0.1	0.2	0.3	0.4	0.5	0.6	0.7	0.8	0	0.1	0.2	0.3	0.4	0.5	0.6	0.7	0.8	
"+" (Plus) SETTING ("Adjust" Jumper at "+" Setting)																			
"HEAT" Speed	Tap 1	160	190	225	260	295	330	360	385	410	200	240	285	330	360	390	420	455	485
	Tap 2	235	270	315	355	385	415	450	480	515	305	340	385	430	465	500	535	565	600
	Tap 3	345	380	415	455	505	550	580	605	635	455	490	525	565	600	635	680	725	770
	Tap 4	465	505	545	590	630	670	715	760	810	615	660	710	760	805	855	890	930	965
"COOL" Speed	Tap 1	100	120	145	170	200	225	250	275	305	260	290	330	365	400	440	475	515	555
	Tap 2	125	150	175	205	220	240	265	295	320	340	380	420	460	490	520	560	595	630
	Tap 3	155	185	220	255	290	320	350	375	400	480	520	565	605	645	685	725	770	810
	Tap 4	195	235	285	330	365	395	425	460	490	690	735	785	840	885	935	970	1005	1040
"NORM" (Normal) SETTING ("Adjust" Jumper at "NORM" Settings)																			
"HEAT" Speed	Tap 1	140	160	185	210	240	265	295	320	350	160	185	220	255	285	320	350	380	410
	Tap 2	185	215	245	280	315	345	375	405	435	210	250	295	345	380	415	450	485	520
	Tap 3	245	280	320	360	390	420	460	495	535	335	375	420	460	495	530	565	600	635
	Tap 4	375	410	445	480	520	555	590	620	655	450	490	535	580	620	655	695	735	775
"COOL" Speed	Tap 1	80	100	120	140	170	195	215	235	255	180	220	265	305	335	360	390	425	455
	Tap 2	90	115	140	170	190	215	235	260	285	240	270	310	350	385	420	455	485	520
	Tap 3	135	155	185	210	240	265	290	310	335	360	400	445	490	515	545	580	620	660
	Tap 4	155	190	225	265	295	325	355	390	420	495	540	585	630	665	695	745	790	835
"," (Minus) SETTING ("Adjust" Jumper at "," Setting)																			
"HEAT" Speed	Tap 1	105	125	150	175	200	225	245	265	290	140	160	180	205	225	250	275	305	335
	Tap 2	140	165	190	220	250	275	300	325	350	170	200	235	270	305	335	365	395	425
	Tap 3	185	215	245	275	310	345	380	410	440	235	270	315	355	390	425	455	485	515
	Tap 4	245	280	315	355	390	425	450	480	510	335	375	420	460	500	535	570	605	640
"COOL" Speed	Tap 1	60	75	95	115	130	150	175	200	225	150	175	210	240	260	280	310	345	375
	Tap 2	75	90	110	135	155	175	200	220	245	170	200	235	270	305	340	370	400	435
	Tap 3	100	120	150	175	200	220	245	270	295	245	280	325	365	400	435	470	500	535
	Tap 4	135	155	180	200	230	260	285	315	340	370	410	450	490	525	565	595	630	660

BLOWER DATA

G60UHV-60C-090 BLOWER PERFORMANCE (less filter)

Side Return Air with Optional RAB Return Air Base

0 through 0.80 in. w.g. External Static Pressure Range

"ADJUST" Switch Positions	Speed Switch Positions							
	Second Stage "HEAT" Speed - cfm				Second Stage "COOL" Speed - cfm			
	1	1 2	3	4	1	2	3	1 4
+	1505	1690	1900	2090	1625	1715	1940	2175
¹ NORM	1370	1535	1745	1915	1450	1560	1765	1945
—	1215	1375	1535	1705	1310	1405	1595	1795

"ADJUST" Switch Positions	First Stage "HEAT" Speed - cfm				First Stage "COOL" Speed - cfm			
	1	1 2	3	4	1	2	3	1 4
	+	1370	1540	1745	1925	1130	1205	1360
¹ NORM	1240	1405	1565	1765	1025	1100	1240	1385
—	1135	1265	1420	1560	900	985	1115	1240

¹ Factory default jumper setting.

N/A - First and second stage HEAT positions shown cannot be used on this model.

NOTES - The effect of static pressure is included in air volumes shown.

First stage HEAT is approximately 91% of the same second stage HEAT speed position.

First stage COOL (two-stage air conditioning units only) is approximately 70% of the same second stage COOL speed position.

Continuous Fan Only speed is approximately 38% of the same second stage COOL speed position - minimum 500 cfm.

Lennox Harmony III™ Zone Control Applications - Minimum blower speed is 478 cfm.

G60UHV-60C-090 BLOWER MOTOR WATTS

Jumper Speed Positions	Motor Watts @ Various External Static Pressures - in. wg.																		
	First Stage									Second Stage									
	0	0.1	0.2	0.3	0.4	0.5	0.6	0.7	0.8	0	0.1	0.2	0.3	0.4	0.5	0.6	0.7	0.8	
"+" (Plus) SETTING ("Adjust" Jumper at "+" Setting)																			
"HEAT" Speed	Tap 1	150	175	210	240	270	295	330	360	395	190	220	255	290	330	365	400	440	475
	Tap 2	200	235	280	320	355	390	430	465	500	270	305	350	390	430	470	505	545	580
	Tap 3	310	350	395	435	465	500	535	575	615	405	445	490	535	580	625	665	700	740
	Tap 4	430	465	505	540	590	640	675	715	750	570	605	645	685	725	770	815	860	905
"COOL" Speed	Tap 1	95	115	140	165	190	210	240	265	290	245	280	315	355	395	435	460	490	520
	Tap 2	100	125	155	185	215	240	265	290	315	290	330	375	420	455	490	520	550	580
	Tap 3	145	175	205	235	265	290	325	360	390	440	480	525	570	615	660	695	730	765
	Tap 4	200	230	270	310	345	375	410	445	480	605	660	725	790	820	850	900	955	1005
"NORM" (Normal) SETTING ("Adjust" Jumper at "NORM" Setting)																			
"HEAT" Speed	Tap 1	125	145	175	200	225	250	275	305	330	140	170	210	245	275	300	330	360	390
	Tap 2	155	185	220	255	285	315	345	380	415	185	225	270	315	345	375	415	450	485
	Tap 3	200	240	285	330	365	395	430	470	505	335	365	395	430	460	495	535	580	620
	Tap 4	325	360	400	440	475	515	550	585	620	400	445	495	545	595	650	680	710	740
"COOL" Speed	Tap 1	70	90	115	135	160	190	210	230	255	185	210	240	270	305	345	375	405	435
	Tap 2	90	105	125	150	175	200	225	250	275	205	240	290	335	375	410	440	475	505
	Tap 3	120	145	170	195	225	255	280	300	325	325	365	415	465	500	530	560	595	625
	Tap 4	145	175	215	250	280	315	345	370	395	435	475	520	565	605	650	695	735	780
"-" (Minus) SETTING ("Adjust" Jumper at "-" Setting)																			
"HEAT" Speed	Tap 1	95	115	140	165	190	215	240	265	290	125	145	165	190	215	245	270	295	320
	Tap 2	130	155	180	205	235	265	290	315	345	150	175	210	240	270	300	335	370	405
	Tap 3	155	185	220	255	295	335	365	395	430	200	230	270	310	345	385	415	450	480
	Tap 4	200	240	290	340	360	380	420	460	500	280	320	365	410	440	470	510	545	585
"COOL" Speed	Tap 1	50	65	90	115	130	150	170	195	215	140	165	190	215	245	275	300	330	360
	Tap 2	65	85	105	130	155	175	200	220	245	155	185	220	255	285	320	355	390	420
	Tap 3	90	110	135	155	185	210	230	250	270	230	265	300	335	380	425	455	490	520
	Tap 4	120	145	170	195	225	255	280	305	330	320	365	420	470	505	535	570	600	635

BLOWER DATA

G60UHV-60C-110 BLOWER PERFORMANCE (less filter)

Bottom Return Air, Return Air from Both Sides or Return Air from Bottom and One Side.

0 through 0.80 in. w.g. External Static Pressure Range

"ADJUST" Switch Positions	Speed Switch Positions							
	Second Stage "HEAT" Speed - cfm				Second Stage "COOL" Speed - cfm			
	1	1 2	3	4	1	2	3	1 4
+	1510	1700	1895	2105	1610	1730	1955	2185
¹ NORM	1365	1545	1725	1915	1460	1575	1780	1995
—	N/A	1375	1545	1715	1295	1395	1600	1780

"ADJUST" Switch Positions	First Stage "HEAT" Speed - cfm				First Stage "COOL" Speed - cfm			
	1	1 2	3	4	1	2	3	1 4
	+	1370	1560	1750	1925	1125	1190	1350
¹ NORM	1245	1410	1590	1760	1015	1090	1230	1360
—	N/A	1255	1420	1575	900	975	1110	1235

¹ Factory default jumper setting.

N/A - First and second stage HEAT positions shown cannot be used on this model.

NOTES - The effect of static pressure is included in air volumes shown.

First stage HEAT is approximately **91%** of the same second stage HEAT speed position.

First stage COOL (two-stage air conditioning units only) is approximately **70%** of the same second stage COOL speed position.

Continuous Fan Only speed is approximately **38%** of the same second stage COOL speed position - minimum 500 cfm.

Lennox Harmony III™ Zone Control Applications - Minimum blower speed is 483 cfm.

G60UHV-60C-110 BLOWER MOTOR WATTS

Jumper Speed Positions	Motor Watts @ Various External Static Pressures - in. wg.																		
	First Stage									Second Stage									
	0	0.1	0.2	0.3	0.4	0.5	0.6	0.7	0.8	0	0.1	0.2	0.3	0.4	0.5	0.6	0.7	0.8	
"+" (Plus) SETTING ("Adjust" Jumper at "+" Setting)																			
"HEAT" Speed	Tap 1	160	190	220	255	285	315	345	370	400	205	235	275	310	340	375	410	445	480
	Tap 2	220	255	290	330	365	395	435	470	505	290	325	365	410	445	475	515	550	585
	Tap 3	320	355	395	440	475	510	545	580	615	410	450	495	540	575	615	650	690	725
	Tap 4	435	465	505	540	585	635	670	705	740	530	580	635	685	735	785	830	875	920
"COOL" Speed	Tap 1	95	120	150	175	200	220	240	265	290	245	280	325	365	405	445	475	510	540
	Tap 2	110	135	170	200	225	250	270	295	320	295	340	385	430	465	500	525	555	580
	Tap 3	160	190	220	250	280	305	335	365	395	425	475	525	575	615	655	690	725	765
	Tap 4	210	240	280	320	355	390	420	455	485	605	660	720	780	830	875	915	955	995
"NORM" (Normal) SETTING ("Adjust" Jumper at "NORM" Setting)																			
"HEAT" Speed	Tap 1	140	160	185	205	235	260	285	310	335	155	185	215	250	275	300	335	370	405
	Tap 2	175	205	240	270	300	330	365	400	430	215	250	285	325	360	390	425	465	500
	Tap 3	245	280	315	355	390	420	460	495	530	290	330	380	425	465	500	530	555	580
	Tap 4	325	360	405	445	475	510	545	580	620	410	450	495	540	580	625	665	700	740
"COOL" Speed	Tap 1	75	95	120	140	165	190	210	230	255	195	225	260	290	320	350	385	425	460
	Tap 2	95	115	140	165	190	215	235	260	285	240	275	310	350	385	420	455	490	525
	Tap 3	130	155	175	200	230	255	280	310	335	340	375	420	460	495	530	565	600	635
	Tap 4	155	185	220	255	280	300	335	370	400	475	515	555	595	645	690	735	780	825
"-" (Minus) SETTING ("Adjust" Jumper at "-" Setting)																			
"HEAT" Speed	Tap 1	N/A	N/A	N/A	N/A	N/A	N/A	N/A	N/A	N/A	N/A	N/A	N/A	N/A	N/A	N/A	N/A	N/A	N/A
	Tap 2	135	160	185	215	240	270	290	315	335	155	185	220	255	285	320	350	380	410
	Tap 3	170	200	235	270	305	335	365	395	425	225	255	290	325	360	395	430	465	505
	Tap 4	230	270	310	355	385	415	450	485	515	310	345	380	415	460	500	535	565	595
"COOL" Speed	Tap 1	60	75	100	120	140	165	180	200	220	150	170	195	215	250	285	310	340	370
	Tap 2	70	90	110	135	155	175	200	225	250	160	190	225	265	300	330	360	390	425
	Tap 3	100	120	145	165	195	220	240	255	275	240	280	320	365	395	425	460	495	525
	Tap 4	140	160	180	200	230	260	280	305	325	330	370	420	465	505	540	570	595	625

BLOWER DATA

G60UHV-60C-110 BLOWER PERFORMANCE (less filter)

Single Side Return Air - Air volumes in bold require field fabricated transition to accommodate 20 x 25 x 1 in. cleanable air filter in order to maintain proper air velocity across the filter.

0 through 0.80 in. w.g. External Static Pressure Range

"ADJUST" Switch Positions	Speed Switch Positions							
	Second Stage "HEAT" Speed - cfm				Second Stage "COOL" Speed - cfm			
	1	1 2	3	4	1	2	3	1 4
+	1540	1750	1945	2170	1635	1760	1995	2225
¹ NORM	1385	1635	1785	1960	1485	1610	1820	2035
—	1230	1390	1585	1760	1310	1415	1620	1815
"ADJUST" Switch Positions	First Stage "HEAT" Speed - cfm				First Stage "COOL" Speed - cfm			
	1	1 2	3	4	1	2	3	1 4
	+	1390	1595	1785	1955	1140	1215	1370
¹ NORM	1255	1425	1615	1800	1030	1105	1245	1400
—	1135	1265	1435	1610	925	990	1125	1255

¹ Factory default jumper setting.

NOTES - The effect of static pressure included in air volumes shown.

First stage HEAT is approximately **91%** of the same second stage HEAT speed position.

First stage COOL (two-stage air conditioning units only) is approximately **70%** of the same second stage COOL speed position.

Continuous Fan Only speed is approximately **38%** of the same second stage COOL speed position - minimum 500 cfm.

Lennox Harmony III™ Zone Control Applications - Minimum blower speed is 483 cfm.

G60UHV-60C-110 BLOWER MOTOR WATTS

Jumper Speed Positions	Motor Watts @ Various External Static Pressures - in. wg.																		
	First Stage									Second Stage									
	0	0.1	0.2	0.3	0.4	0.5	0.6	0.7	0.8	0	0.1	0.2	0.3	0.4	0.5	0.6	0.7	0.8	
"+" (Plus) SETTING ("Adjust" Jumper at "+" Setting)																			
"HEAT" Speed	Tap 1	155	185	220	255	280	305	340	375	410	225	255	285	320	355	390	420	445	475
	Tap 2	240	270	310	345	385	425	450	475	505	325	360	400	445	480	515	540	570	595
	Tap 3	360	390	420	450	490	530	565	600	635	460	490	525	560	600	640	675	715	750
	Tap 4	460	495	535	575	615	655	690	725	760	625	670	715	755	805	850	890	925	965
"COOL" Speed	Tap 1	105	125	150	175	195	220	240	265	290	265	295	330	365	410	450	480	510	540
	Tap 2	125	150	175	200	220	240	270	295	320	330	365	400	440	475	515	545	580	615
	Tap 3	160	190	220	250	275	305	335	365	395	470	515	560	605	645	680	715	755	790
	Tap 4	215	250	285	325	360	395	425	455	485	700	740	780	820	875	930	965	1005	1040
"NORM" (Normal) SETTING ("Adjust" Jumper at "NORM" Setting)																			
"HEAT" Speed	Tap 1	130	155	180	205	235	260	285	310	335	155	185	220	255	280	300	330	365	395
	Tap 2	170	200	235	270	305	340	370	400	430	245	275	310	345	375	405	435	470	505
	Tap 3	265	295	330	360	400	445	470	500	530	355	385	420	450	490	530	565	600	635
	Tap 4	360	395	435	475	510	540	565	595	620	455	490	525	560	605	650	690	730	765
"COOL" Speed	Tap 1	70	90	115	135	165	190	210	235	255	190	220	255	295	320	350	380	410	435
	Tap 2	95	115	135	155	180	205	230	250	270	245	280	315	355	395	430	460	490	520
	Tap 3	135	155	175	195	220	245	270	300	325	375	410	445	485	510	540	580	615	655
	Tap 4	160	190	225	260	290	320	350	380	410	420	485	565	640	680	715	755	800	840
"-" (Minus) SETTING ("Adjust" Jumper at "-" Setting)																			
"HEAT" Speed	Tap 1	95	115	145	175	195	215	240	265	290	125	150	175	200	225	250	270	295	320
	Tap 2	140	160	185	210	240	265	290	315	340	160	190	225	260	285	305	340	375	410
	Tap 3	180	205	240	270	305	335	370	400	430	235	270	310	350	385	420	450	480	505
	Tap 4	245	280	315	345	385	420	450	480	515	320	360	405	450	480	510	535	565	590
"COOL" Speed	Tap 1	65	80	100	120	140	160	180	200	220	150	170	195	215	250	285	310	340	365
	Tap 2	70	90	110	135	155	180	200	225	245	165	195	225	260	290	320	355	385	420
	Tap 3	95	120	145	170	195	220	240	260	275	260	290	325	360	395	430	465	500	530
	Tap 4	135	155	175	195	225	255	280	300	325	370	400	440	475	505	540	570	605	640

BLOWER DATA

G60UHV-60C-110 BLOWER PERFORMANCE (less filter)

Side Return Air with Optional RAB Return Air Base

0 through 0.80 in. w.g. External Static Pressure Range

"ADJUST" Switch Positions	Speed Switch Positions							
	Second Stage "HEAT" Speed - cfm				Second Stage "COOL" Speed - cfm			
	1	1 2	3	4	1	2	3	1 4
+	1490	1680	1875	2085	1620	1735	1950	2185
¹ NORM	1340	1525	1715	1885	1470	1595	1780	1975
—	N/A	1350	1525	1700	1305	1400	1605	1785

"ADJUST" Switch Positions	First Stage "HEAT" Speed - cfm				First Stage "COOL" Speed - cfm			
	1	1 2	3	4	1	2	3	1 4
	+	1375	1570	1765	1935	1017	1075	1375
¹ NORM	1255	1425	1570	1750	1025	1100	1235	1385
—	N/A	1255	1415	1880	920	990	1000	1110

¹ Factory default jumper setting.

N/A - First and second stage HEAT positions shown cannot be used on this model.

NOTES - The effect of static pressure is included in air volumes shown.

First stage HEAT is approximately **91%** of the same second stage HEAT speed position.

First stage COOL (two-stage air conditioning units only) is approximately **70%** of the same second stage COOL speed position.

Continuous Fan Only speed is approximately **38%** of the same second stage COOL speed position - minimum 500 cfm.

Lennox Harmony III™ Zone Control Applications - Minimum blower speed is 483 cfm.

G60UHV-60C-110 BLOWER MOTOR WATTS

Jumper Speed Positions	Motor Watts @ Various External Static Pressures - in. wg.																		
	First Stage									Second Stage									
	0	0.1	0.2	0.3	0.4	0.5	0.6	0.7	0.8	0	0.1	0.2	0.3	0.4	0.5	0.6	0.7	0.8	
"+" (Plus) SETTING ("Adjust" Jumper at "+" Setting)																			
"HEAT" Speed	Tap 1	145	175	215	250	275	300	325	355	380	190	220	260	295	330	360	390	420	455
	Tap 2	225	255	290	325	360	395	425	460	490	280	315	355	390	430	470	500	530	560
	Tap 3	340	375	410	445	480	510	550	585	625	410	445	480	515	540	570	610	655	695
	Tap 4	445	480	515	550	595	635	675	710	750	535	580	635	685	720	755	800	845	885
"COOL" Speed	Tap 1	95	120	145	170	195	220	240	265	290	260	290	325	360	394	425	455	480	510
	Tap 2	115	135	160	190	215	240	265	290	315	325	355	390	425	455	490	515	545	575
	Tap 3	155	180	215	250	275	300	335	365	395	445	485	530	575	610	650	690	725	765
	Tap 4	210	240	275	310	345	375	410	445	480	645	685	730	770	825	875	915	950	985
"NORM" (Normal) SETTING ("Adjust" Jumper at "NORM" Setting)																			
"HEAT" Speed	Tap 1	130	155	185	210	235	260	285	305	330	145	175	205	235	260	290	315	345	375
	Tap 2	165	195	230	265	300	330	360	390	420	205	235	270	305	340	370	405	435	470
	Tap 3	225	260	300	345	365	385	420	455	490	300	335	375	420	460	500	525	550	580
	Tap 4	335	365	395	425	460	490	530	570	610	400	440	480	520	560	600	635	670	705
"COOL" Speed	Tap 1	75	95	115	140	165	190	210	230	245	185	215	245	280	315	355	380	410	435
	Tap 2	95	115	135	160	185	210	230	250	275	250	275	305	335	380	425	450	475	500
	Tap 3	135	150	175	195	225	255	280	300	325	335	375	420	460	495	525	560	595	625
	Tap 4	160	185	215	250	275	305	335	370	400	480	515	550	585	620	655	700	745	785
"-" (Minus) SETTING ("Adjust" Jumper at "-" Setting)																			
"HEAT" Speed	Tap 1	N/A	N/A	N/A	N/A	N/A	N/A	N/A	N/A	N/A	N/A	N/A	N/A	N/A	N/A	N/A	N/A	N/A	N/A
	Tap 2	125	150	175	200	225	250	275	305	330	150	175	205	235	265	290	320	345	375
	Tap 3	165	195	230	265	295	325	355	385	415	205	235	270	305	340	375	405	440	470
	Tap 4	235	265	295	330	360	390	425	460	495	290	320	360	400	435	470	505	535	570
"COOL" Speed	Tap 1	60	75	100	120	135	155	175	195	220	145	165	190	215	245	280	305	330	360
	Tap 2	70	90	110	135	155	170	195	215	235	170	195	225	255	285	320	350	380	410
	Tap 3	90	110	140	165	190	210	230	250	275	245	280	315	345	385	425	450	480	510
	Tap 4	130	150	175	200	225	245	275	305	330	350	385	425	465	500	530	560	590	620

BLOWER DATA

G60UHV-60D-135 BLOWER PERFORMANCE (less filter)

Bottom Return Air, Return Air from Both Sides or Return Air from Bottom and One Side.

0 through 0.80 in. w.g. External Static Pressure Range

"ADJUST" Switch Positions	Speed Switch Positions							
	Second Stage "HEAT" Speed - cfm				Second Stage "COOL" Speed - cfm			
	1	1 2	3	4	1	2	3	1 4
+	1470	1665	1855	2050	1575	1695	1900	2140
¹ NORM	1335	1520	1695	1870	1430	1540	1745	1945
—	N/A	1340	1510	1675	1275	1370	1565	1735

"ADJUST" Switch Positions	First Stage "HEAT" Speed - cfm				First Stage "COOL" Speed - cfm			
	1	1 2	3	4	1	2	3	1 4
	+	1345	1520	1710	1880	1100	1180	1330
¹ NORM	1220	1375	1545	1725	1000	1075	1205	1350
—	N/A	1230	1380	1535	900	670	1095	1210

¹ Factory default jumper setting.

N/A - First and second stage HEAT positions shown cannot be used on this model.

NOTES - The effect of static pressure is included in air volumes shown.

First stage HEAT is approximately **91%** of the same second stage HEAT speed position.

First stage COOL (two-stage air conditioning units only) is approximately **70%** of the same second stage COOL speed position.

Continuous Fan Only speed is approximately **38%** of the same second stage COOL speed position - minimum 500 cfm.

Lennox Harmony III™ Zone Control Applications - Minimum blower speed is 495 cfm.

G60UHV-60D-135 BLOWER MOTOR WATTS

Jumper Speed Positions	Motor Watts @ Various External Static Pressures - in. wg.																		
	First Stage									Second Stage									
	0	0.1	0.2	0.3	0.4	0.5	0.6	0.7	0.8	0	0.1	0.2	0.3	0.4	0.5	0.6	0.7	0.8	
"+" (Plus) SETTING ("Adjust" Jumper at "+" Setting)																			
"HEAT" Speed	Tap 1	125	145	170	195	230	260	290	320	350	150	175	210	245	280	315	345	380	410
	Tap 2	155	190	225	265	305	340	370	400	430	210	245	280	315	355	400	435	475	515
	Tap 3	225	260	305	345	380	420	460	495	535	285	320	365	410	450	490	530	570	610
	Tap 4	295	335	380	425	470	510	550	590	625	390	430	475	520	570	615	660	705	750
"COOL" Speed	Tap 1	70	95	120	145	170	190	210	230	255	175	205	245	280	320	365	400	430	465
	Tap 2	85	110	140	170	190	210	235	255	275	215	250	290	330	370	405	445	485	525
	Tap 3	125	150	175	205	230	260	285	315	345	310	355	400	450	480	515	560	605	650
	Tap 4	145	175	215	255	290	325	360	390	425	430	475	525	570	630	690	740	790	840
"NORM" (Normal) SETTING ("Adjust" Jumper at "NORM" Setting)																			
"HEAT" Speed	Tap 1	95	120	145	175	195	220	245	274	300	125	150	175	195	230	260	290	315	345
	Tap 2	130	155	190	220	250	275	305	335	365	160	190	225	260	300	335	365	400	430
	Tap 3	175	205	240	275	315	355	385	420	450	215	250	290	325	375	420	450	480	515
	Tap 4	220	260	305	350	390	430	470	505	540	285	325	375	425	460	490	535	580	625
"COOL" Speed	Tap 1	60	80	105	125	145	165	185	205	230	140	165	200	230	265	295	330	360	395
	Tap 2	75	90	115	135	160	180	205	230	250	170	200	235	275	310	345	380	415	445
	Tap 3	85	110	145	175	200	220	245	270	295	240	280	320	360	400	445	475	510	545
	Tap 4	130	155	180	200	235	265	295	330	360	325	370	415	460	510	555	595	635	680
"-" (Minus) SETTING ("Adjust" Jumper at "-" Setting)																			
"HEAT" Speed	Tap 1	N/A	N/A	N/A	N/A	N/A	N/A	N/A	N/A	N/A	N/A	N/A	N/A	N/A	N/A	N/A	N/A	N/A	N/A
	Tap 2	100	125	150	180	200	220	245	270	295	125	150	175	200	230	260	290	320	350
	Tap 3	130	155	185	220	250	275	310	340	370	160	190	220	250	285	320	355	385	420
	Tap 4	155	190	230	275	305	340	370	405	435	205	240	285	330	370	410	445	475	510
"COOL" Speed	Tap 1	50	65	85	105	120	140	155	175	195	110	130	160	185	210	235	265	290	320
	Tap 2	60	75	95	120	135	155	175	195	215	125	150	185	215	240	265	295	325	355
	Tap 3	70	90	115	145	165	190	210	230	250	160	195	240	285	320	360	390	415	445
	Tap 4	90	115	140	170	195	220	245	270	295	225	265	310	355	390	430	465	500	535

BLOWER DATA

G60UHV-60D-135 BLOWER PERFORMANCE (less filter)

Single Side Return Air - Air volumes in bold require field fabricated transition to accommodate 20 x 25 x 1 in. cleanable air filter in order to maintain proper air velocity across the filter.

0 through 0.80 in. w.g. External Static Pressure Range

"ADJUST" Switch Positions	Speed Switch Positions							
	Second Stage "HEAT" Speed - cfm				Second Stage "COOL" Speed - cfm			
	1	1 2	3	4	1	2	3	1 4
+	1405	1600	1775	1965	1500	1620	1815	2040
¹ NORM	N/A	1440	1635	1800	1360	1470	1660	1860
—	N/A	N/A	1445	1620	1225	1310	1490	1670

"ADJUST" Switch Positions	First Stage "HEAT" Speed - cfm				First Stage "COOL" Speed - cfm			
	1	1 2	3	4	1	2	3	1 4
	+	1285	1450	1635	1800	1075	1150	1275
¹ NORM	N/A	1325	1485	1660	955	1040	1165	1300
—	N/A	N/A	1325	1460	870	930	1065	1175

¹ Factory default jumper setting.

N/A - First and second stage HEAT positions shown cannot be used on this model.

NOTES - The effect of static pressure is included in air volumes shown.

First stage HEAT is approximately **91%** of the same second stage HEAT speed position.

First stage COOL (two-stage air conditioning units only) is approximately **70%** of the same second stage COOL speed position.

Continuous Fan Only speed is approximately **38%** of the same second stage COOL speed position - minimum 500 cfm.

Lennox Harmony III™ Zone Control Applications - Minimum blower speed is 495 cfm.

G60UHV-60D-135 BLOWER MOTOR WATTS

Jumper Speed Positions	Motor Watts @ Various External Static Pressures - in. wg.																		
	First Stage									Second Stage									
	0	0.1	0.2	0.3	0.4	0.5	0.6	0.7	0.8	0	0.1	0.2	0.3	0.4	0.5	0.6	0.7	0.8	
"+" (Plus) SETTING ("Adjust" Jumper at "+" Setting)																			
"HEAT" Speed	Tap 1	120	145	170	195	220	245	280	315	350	145	170	205	235	270	305	335	370	405
	Tap 2	170	195	220	250	285	320	355	390	425	200	235	270	305	350	390	425	460	500
	Tap 3	230	260	295	330	365	395	435	475	515	285	320	360	400	445	490	530	565	605
	Tap 4	310	345	390	435	465	495	540	585	630	380	420	465	505	560	615	665	715	765
"COOL" Speed	Tap 1	75	95	120	140	165	190	210	235	255	165	195	230	265	310	350	380	410	435
	Tap 2	85	110	135	160	185	205	235	260	285	210	250	290	335	370	405	440	475	510
	Tap 3	115	140	170	195	230	260	285	315	340	300	335	380	420	460	495	550	600	650
	Tap 4	145	175	205	240	275	315	350	390	425	430	480	530	585	625	660	710	760	810
"NORM" (Normal) SETTING ("Adjust" Jumper at "NORM" Setting)																			
"HEAT" Speed	Tap 1	N/A	N/A	N/A	N/A	N/A	N/A	N/A	N/A	N/A	N/A	N/A	N/A	N/A	N/A	N/A	N/A	N/A	N/A
	Tap 2	130	155	180	210	245	275	305	335	365	150	180	215	255	285	320	350	380	410
	Tap 3	170	195	225	250	300	345	375	410	440	220	255	290	325	360	395	435	470	510
	Tap 4	215	250	295	335	375	420	455	490	525	280	325	375	430	465	500	540	580	620
"COOL" Speed	Tap 1	60	75	100	120	140	160	180	200	220	135	160	190	220	255	290	325	355	390
	Tap 2	70	90	115	135	160	185	205	230	255	160	190	225	265	300	335	370	400	435
	Tap 3	95	115	140	165	190	215	240	265	290	250	280	310	345	380	420	455	495	530
	Tap 4	125	150	180	205	235	260	290	320	350	325	365	405	450	490	535	585	635	685
"-" (Minus) SETTING ("Adjust" Jumper at "-" Setting)																			
"HEAT" Speed	Tap 1	N/A	N/A	N/A	N/A	N/A	N/A	N/A	N/A	N/A	N/A	N/A	N/A	N/A	N/A	N/A	N/A	N/A	N/A
	Tap 2	N/A	N/A	N/A	N/A	N/A	N/A	N/A	N/A	N/A	N/A	N/A	N/A	N/A	N/A	N/A	N/A	N/A	N/A
	Tap 3	130	155	180	210	235	260	295	330	365	160	185	215	245	280	310	350	390	425
	Tap 4	165	190	220	245	285	325	360	395	430	215	250	285	320	360	400	440	480	520
"COOL" Speed	Tap 1	50	65	85	105	120	135	160	180	205	100	120	150	180	215	245	270	295	320
	Tap 2	50	65	90	115	135	155	175	195	215	120	145	170	195	230	270	300	325	355
	Tap 3	60	85	115	145	165	190	210	235	255	180	205	235	265	300	335	370	410	445
	Tap 4	90	110	140	165	190	215	240	260	285	225	260	305	350	390	430	465	500	530

BLOWER DATA

G60UHV-60D-135 BLOWER PERFORMANCE (less filter)

Side Return Air with Optional RAB Return Air Base

0 through 0.80 in. w.g. External Static Pressure Range

"ADJUST" Switch Positions	Speed Switch Positions							
	Second Stage "HEAT" Speed - cfm				Second Stage "COOL" Speed - cfm			
	1	1 2	3	4	1	2	3	1 4
+	1425	1615	1795	1975	1505	1620	1815	2035
¹ NORM	N/A	1455	1640	1805	1370	1470	1670	1850
—	N/A	N/A	1455	1630	1225	1320	1500	1670

"ADJUST" Switch Positions	First Stage "HEAT" Speed - cfm				First Stage "COOL" Speed - cfm			
	1	1 2	3	4	1	2	3	1 4
	+	1305	1470	1655	1825	1075	1155	1295
¹ NORM	N/A	1345	1505	1670	980	1050	1175	1305
—	N/A	N/A	1340	1475	875	935	1070	1180

¹ Factory default jumper setting.

N/A - First and second stage HEAT positions shown cannot be used on this model.

NOTES - The effect of static pressure is included in air volumes shown.

First stage HEAT is approximately 91% of the same second stage HEAT speed position.

First stage COOL (two-stage air conditioning units only) is approximately 70% of the same second stage COOL speed position.

Continuous Fan Only speed is approximately 38% of the same second stage COOL speed position - minimum 500 cfm.

Lennox Harmony III™ Zone Control Applications - Minimum blower speed is 495 cfm.

G60UHV-60D-135 BLOWER MOTOR WATTS - Side Return with RAB

Jumper Speed Positions	Motor Watts @ Various External Static Pressures - in. wg.																		
	First Stage									Second Stage									
	0	0.1	0.2	0.3	0.4	0.5	0.6	0.7	0.8	0	0.1	0.2	0.3	0.4	0.5	0.6	0.7	0.8	
"+" (Plus) SETTING ("Adjust" Jumper at "+" Setting)																			
"HEAT" Speed	Tap 1	125	145	170	195	225	255	280	310	340	145	170	205	235	270	300	330	365	395
	Tap 2	165	190	215	245	285	325	355	385	415	200	230	270	305	345	385	425	460	500
	Tap 3	215	250	295	335	365	390	430	470	505	265	305	355	400	440	480	515	550	585
	Tap 4	290	330	375	420	455	490	530	565	605	365	410	460	505	550	595	635	675	715
"COOL" Speed	Tap 1	75	95	120	140	165	190	210	230	255	175	205	235	265	305	340	370	405	435
	Tap 2	80	105	130	160	185	205	230	255	275	210	240	275	310	350	390	425	460	495
	Tap 3	120	140	165	190	225	255	285	310	335	285	325	370	410	460	505	545	585	625
	Tap 4	155	175	200	225	265	300	335	365	395	400	445	500	550	600	650	695	745	795
"NORM" (Normal) SETTING ("Adjust" Jumper at "NORM" Setting)																			
"HEAT" Speed	Tap 1	N/A	N/A	N/A	N/A	N/A	N/A	N/A	N/A	N/A	N/A	N/A	N/A	N/A	N/A	N/A	N/A	N/A	N/A
	Tap 2	135	155	180	200	235	270	300	330	360	155	180	210	240	275	315	350	385	420
	Tap 3	165	195	230	260	295	330	365	395	430	215	250	290	330	365	405	435	470	500
	Tap 4	230	255	290	320	365	410	445	480	515	280	320	365	405	445	485	525	560	600
"COOL" Speed	Tap 1	60	80	100	125	140	155	180	210	235	135	160	185	215	245	275	310	340	375
	Tap 2	70	90	115	135	160	180	200	220	240	165	190	220	250	295	340	365	395	425
	Tap 3	85	110	140	165	190	215	240	260	285	220	255	300	340	385	430	465	495	530
	Tap 4	120	140	170	195	230	260	285	310	335	310	350	400	450	485	520	560	605	645
"-" (Minus) SETTING ("Adjust" Jumper at "-" Setting)																			
"HEAT" Speed	Tap 1	N/A	N/A	N/A	N/A	N/A	N/A	N/A	N/A	N/A	N/A	N/A	N/A	N/A	N/A	N/A	N/A	N/A	N/A
	Tap 2	N/A	N/A	N/A	N/A	N/A	N/A	N/A	N/A	N/A	N/A	N/A	N/A	N/A	N/A	N/A	N/A	N/A	N/A
	Tap 3	130	155	180	205	235	265	295	325	360	155	185	215	245	280	310	350	385	420
	Tap 4	165	190	220	250	295	335	365	390	420	210	240	275	310	350	390	425	460	495
"COOL" Speed	Tap 1	45	60	85	110	125	140	160	180	200	100	120	155	185	205	225	255	285	310
	Tap 2	50	65	90	110	135	155	175	195	215	120	140	170	200	230	260	290	320	350
	Tap 3	70	90	115	140	165	185	210	230	250	160	190	225	265	295	330	365	400	430
	Tap 4	90	110	140	170	190	215	235	260	285	215	255	300	345	385	425	460	490	520



Visit us at www.lennox.com

For the latest technical information, www.lennoxdavenet.com

Contact us at 1-800-4-LENNOX

NOTE - Due to Lennox' ongoing commitment to quality, Specifications, Ratings and Dimensions subject to change without notice and without incurring liability. Improper installation, adjustment, alteration, service or maintenance can cause property damage or personal injury. Installation and service must be performed by a qualified installer and servicing agency.

©2006 Lennox Industries Inc.