

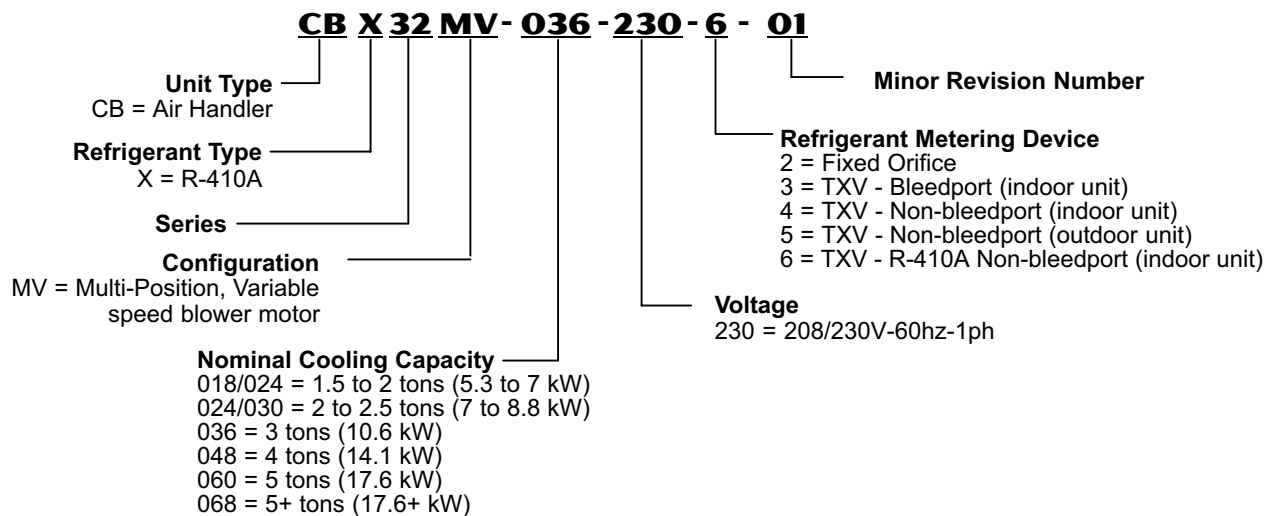

Nominal Capacity - 1.5 to 5+ Tons
Optional Electric Heat - 2.5 to 25 kW

MODEL NUMBER IDENTIFICATION



FEATURES

CONTENTS

Blower Data	Pages 7-11
Dimensions	Pages 15-17
Electric Heat Data	Pages 12-14
Features	Pages 2-4
Installation Clearances	Page 4
Model Number Identification	Page 1
Specifications	Pages 5-6

APPROVALS

Tested with matching air conditioners and heat pump units in the Lennox Research Laboratory environmental test room in accordance with ARI Standard 210/240.

Optional electric heaters are rated in accordance with US Department of Energy (DOE) test procedures and Federal Trade Commission (FTC) labeling regulations.

Blower performance data according to unit tests conducted in Lennox air test chamber.

Air handlers are UL Listed to US and Canadian safety standards and components within are bonded for grounding to meet safety standards for servicing required by CEC and NEC.

ISO 9001 Registered Manufacturing Quality System.

WARRANTY

All covered components - five years in residential applications, one year in non-residential applications. Refer to Lennox Limited Warranty Certificate included with each unit for additional details.

APPLICATIONS

1.5 to 5+ ton nominal sizes.

Multi-position (up-flow, down-flow or horizontal) applications.

Applicable to expansion valve systems in R-410A cooling applications and check and expansion valve systems in R-410A heat pump applications.

Applicable to Lennox Harmony III™ zone control system. Wide-range check and expansion valve is factory installed.

See bulletins in section Air Conditioners for cooling capacities.

See bulletins in section Heat Pump Outdoor Units for cooling and heating capacities.

Optional field installed electric heaters available in several sizes for additive heating capacity.

Zoning Applications

Units can be used with certain zoning systems. Zone control panel **MUST** be able to interface and communicate with the variable speed motor in the unit. Lennox Harmony III™ zoning systems have this capability.

REFRIGERANT SYSTEM

1 Refrigerant Line Connections

Suction (vapor) and liquid lines have sweat connections that extended outside of the cabinet for ease of connection.

See dimension drawings for locations.

2 Check and Expansion Valve Furnished

For use with R-410A systems.

Wide range valve with Chatleff style fitting.

Factory installed on all models, internal to cabinet.

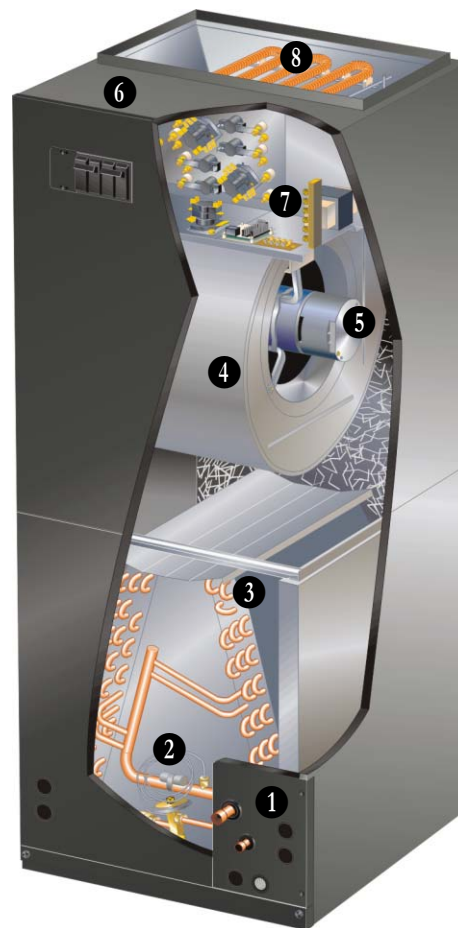

3 Copper Tube/Enhanced Fin Indoor Coil

Lennox designed and fabricated twin coils.

Assembled in "A" configuration.

Provides extra large surface and contact area, excellent heat transfer and low air resistance for maximum efficiency.

Precise circuiting for uniform refrigerant distribution.

Precisely spaced ripple-edged aluminum fins fitted to durable seamless copper tubes.

Fins are strengthened to resist bending and are equipped with collars that grip tubing for maximum contact area.

Lanced fins provide maximum exposure of fin surface to air stream.

Long life copper tubing is easy to service.

Rifled tubing provides superior heat transfer.

Flared shoulder tubing joints and silver soldering provide tight, leakproof joints.

Coil thoroughly factory tested under high pressure to insure leakproof construction.

BLOWER

4 Equipped with Lennox designed and built, direct drive blower.

Each blower is statically and dynamically balanced as an assembly before installation in unit.

Variable speed motor (VSM) is resiliently mounted.

Blower slides out of cabinet for servicing.

5 VSM Blower Motor

Variable speed motor (VSM) maintains specified air volume throughout external static range.

Motor is controlled by BDC3 electronic blower drive control that allows blower to operate at two of eight air volumes or speeds available.

Speeds may be field selected on BDC3 control depending on blower coil unit size and air volume desired.

See blower performance tables.

FEATURES

FILTER

Tool-less access to filter area for quick and easy servicing. Disposable frame type filter furnished and factory installed in rails in cabinet. See Specifications tables for sizes.

CABINET

- 6 Constructed of heavy-gauge galvanized steel. Completely insulated with thick fiberglass insulation. Pre-painted steel cabinets have mildly textured enamel finish with primer coat on unpainted side of all panels. Units are shipped in one piece but may be disassembled into two separate sections for ease of installation in tight applications. See dimension drawings. Thick rubber gasket between sections of the two piece cabinets provides an air tight seal. No external screw heads on sides of cabinet for tight installations without damage to walls or woodwork. Removable panels provide complete service access. Electrical inlets provided in sides and top of cabinet. See dimension drawings for locations.

Multi-Position Capability

Shipped for up-flow and horizontal right-hand discharge. Quickly converted to down-flow or left-hand, horizontal air discharge.

Optional Kit required for conversion to down-flow.

Dual Position Drain Pans

Drain pans designed for up-flow, down-flow or horizontal applications.

Deep, corrosion resistant plastic drain pans have dual pipe drains.

See dimension drawings.

OPTIONS

Down-Flow Additive Base

Additive base required for models with electric heat installed in down-flow position on combustible floors.

Side Return Unit Stand (Up-Flow Only)

Raises unit 16 in. above floor for side return air duct connection.

Eliminates need for wooden platform construction.

All aluminum construction.

Two adjustable frames fit -018/024 thru -060 models.

Wall Hanging Bracket Kit (Up-Flow Only)

Allows unit to be hung on wall at any height.

Consists of heavy-gauge steel support brackets (one for air handler, one for wall mount).

Screws furnished for fastening one bracket to unit.

Bolts for fastening one bracket to wall are field provided.

Horizontal Support Frame Kit

(-018/024 thru -060 models only)

Provides support of unit in horizontal applications.

Consists of (2) 1 x 1-1/2 x 32-5/8 in. and (2) 1 x 3 x 53-7/8 in. painted heavy gauge cold rolled steel support channels with assembly and suspending holes.

Bolts and nuts furnished for field assembly.

Suspending rods must be field provided.

CONTROLS

7 BDC3 Electronic Blower Control

Blower control interfaces variable speed motor with SignatureStat™ Home Comfort Control.

Controls evaporator humidity by controlling blower and compressor staging on two-stage outdoor units.

Two stages - HEAT and COOL (with four different air volume selections for each) are made by simple jumper pins on board.

ADJUST jumper pin allows approximately 10% higher, normal or 10% lower motor speed selection within HEAT and COOL speeds selected for fine tuning air volume.

DELAY jumper pin allows selection blower motor de-humidification profiles during cooling mode.

Option 1 - Motor runs at 100% of capacity until demand met. Once demand is met, motor ramps down to stop.

Option 2 - Motor runs at 100% until demand is met. Once demand is satisfied, motor runs at 100% for 60 seconds then ramps down to stop.

Option 3 - Motor runs at 82% of capacity for approximately 7-1/2 minutes, then 100% capacity (if needed) until demand is satisfied. Once demand is met, motor ramps down to stop.

Option 4 - Motor runs at 50% capacity for 30 seconds, then 82% capacity for approximately 7-1/2 minutes. If demand is not satisfied, motor runs at 100% capacity until demand is met. Once demand is met, motor runs at 50% capacity for 30 seconds, then ramps down to stop.

BDC3 control has two diagnostic indicator lights, "CFM" and "RUN", to assist in servicing.

Accessory relay terminals provide connections for power humidifiers or electronic air cleaners.

Control is factory installed in the unit control box.

Transformer and Blower Cooling Relay

24 volt transformer with in-line fuse and blower cooling relay furnished as standard.

Factory installed in the unit control box.

Terminal strip furnished.

OPTIONS

Thermostat

See Thermostat bulletins in Controls section and Lennox Price Book for a complete list of thermostats.

SignatureStat™ Home Comfort Control

Combination temperature and humidity control in cooling mode.

Auto-changeover

Controls humidity during cooling operation.

Easy-to-use, menu driven thermostat with a back-lit, dot-matrix LCD screen.

Remote outdoor sensor (furnished) allows the thermostat to display outdoor temperature and adjust indoor dewpoint temperature for precision humidity control in cooling mode.

See the SignatureStat Engineering Handbook bulletin in the Controls section for more information.



FEATURES

OPTIONAL ELECTRIC HEAT

- 8 Field install internal to unit cabinet.
Available in several voltages and kW sizes.
See Electric Heat tables.
Helix wound nichrome heating elements exposed directly in air stream resulting in instant heat transfer, low element temperatures and long service life.
Each element equipped with accurately located limit control with fixed temperature off setting and automatic reset.
Supplemental thermal cutoff limit control, provides positive protection in case of excessive temperatures.
Thermal sequencer relay brings elements on and off line, in sequence and equal increments, with time delay between each.
Initiates and terminates blower operation.
Heating control relay(s) furnished as standard.
Control box and access cover constructed of heavy gauge galvanized steel.
Factory assembled with controls installed and wired.
Electric heat low voltage controls plug-in to blower coil unit.

Circuit Breaker Models

- ECB29-5CB, -6CB, -8CB, -9CB, -10CB, -12.5CB, -15CB, -20CB, -25CB and -30CB (208/240V-1ph) and ECB29-15CB, -20CB and -25CB (208/240V-3ph) heaters are equipped with circuit breakers for overload and short circuit protection.
Factory wired and mounted on electric heat unit.
Current sensitive and temperature actuated.
Manual reset.
Circuit breakers qualify as disconnect means at unit in many areas, eliminate the need for field provided disconnect.
Consult local electrical code in your area.

EvenHeater™ Models

- Electric heat is staged to provide supplemental heat to meet desired comfort levels.
EHC control board stages the heat on and off based on the demand of the provided (field installed) supply plenum thermistor.
Temperature set point (85, 100, 115 or 130°F) is selected by use of a jumper pin on the EHC control board.
ECB29EH-9CB, -12.5CB, -15CB and -20CB heaters are equipped with circuit breakers for overload and short circuit protection.
Factory provided and field mounted in electric heat unit.
Current sensitive and temperature actuated.
Manual reset.
Circuit breakers qualify as disconnect means at unit in many areas, eliminate the need for field provided disconnect.
Consult local electrical code in your area.

OPTIONS

Single-Point Power Source Control Box

- Control Box may be used with optional electric heat when single power supply is connected to multi-circuit electric heat.
Field installs external to the unit cabinet on either side or top.
Constructed of heavy gauge steel, baked enamel finish, prepunched mounting holes, electrical inlet knockouts, and terminal strip.
Removeable cover provides easy access.
Dimensions (H x W x D) - 7 x 7 x 4 in.

INSTALLATION CLEARANCES

Cabinet	0 inch (0 mm)
Plenum and Outlet duct on blower/coil units	1 inch (25 mm)
Plenum and Warm air duct within 3 feet (914mm) of cabinet	1 inch (25 mm)
Floor	¹ Combustible

¹ When unit is installed in the down-flow position with electric heat on a combustible floor, an optional down-flow base is required.

SPECIFICATIONS

General Data		Model Number	CBX32MV-018/024	CBX32MV-024/030	CBX32MV-036
	Nominal cooling capacity - tons (kW)		1.5 - 2 (5.3 - 7)	2 - 2.5 (7 - 8.8)	3 (10.6)
	Refrigerant		R-410A	R-410A	R-410A
Connections in. (mm)	Suction (vapor) line - sweat		5/8 (15.8)	3/4 (19)	3/4 (19)
	Liquid line - sweat		3/8 (9.5)	3/8 (9.5)	3/8 (9.5)
	Condensate drain (fpt)		(2) 3/4 (19)	(2) 3/4 (19)	(2) 3/4 (19)
Indoor Coil	Net face area - ft. ² (m ²)		3.56 (0.33)	4.44 (0.41)	5.0 (0.46)
	Tube outside diameter - in. (mm)		3/8 (9.5)	3/8 (9.5)	3/8 (9.5)
	Number of rows		3	3	3
	Fins per inch (fins per m)		12 (472)	12 (472)	12 (472)
Blower Data	Wheel nominal diameter x width - in. (mm)		10 x 7 (279 x 178)	10 x 8 (279 x 203)	10 x 8 (279 x 203)
	Motor output - hp (W)		1/2 (373)	1/2 (373)	1/2 (373)
Filters	¹ Number and size - in.		(1) 15 x 20 x 1	(1) 20 x 20 x 1	(1) 20 x 22 x 1
	mm		381 x 508 x 25	508 x 508 x 25	508 x 559 x 25
Shipping Data - 1 Package - lbs. (kg)			126 (57)	152 (69)	183 (83)
ELECTRICAL DATA					
Voltage - phase - 60hz			208/230V-1ph	208/230V-1ph	208/230V-1ph
² Maximum overcurrent protection (unit only)			15	15	15
Minimum circuit ampacity (unit only)			5	5	5
OPTIONAL ACCESSORIES - MUST BE ORDERED EXTRA					
Down-Flow Combustible Base - Ship. weight - lbs. (kg)			34J72 - 8 (4)	34J73 - 8 (4)	34J73 - 8 (4)
Electric Heat			2.5 to 25 kW - See Electric Heat Data tables		
Horizontal Support Frame Kit - Ship. weight - lbs. (kg)			56J18 - 18 (8)	56J18 - 18 (8)	56J18 - 18 (8)
Side Return Unit Stand (Up-Flow) - Ship. weight - lbs. (kg)			45K31 - 5 (2)	45K32 - 6 (3)	45K32 - 6 (3)
SignatureStat™ Home Comfort Control	2 Heat / 2 Cool - Heat Pump		81M28	81M28	81M28
	2 Heat/2 Cool - Conventional		81M27	81M27	81M27
	1 Heat/1 Cool - Conventional or Heat Pump		81M26	81M26	81M26
Single-Point Power Source Control Box - Ship. wt. - lbs. (kg)			21H39 - 5 (2)	21H39 - 5 (2)	21H39 - 5 (2)
Wall Hanging Bracket Kit (Up-Flow) - Ship. weight - lbs. (kg)			45K30 - 3 (1)	45K30 - 3 (1)	45K30 - 3 (1)

¹ Disposable frame type filter.

² HACR type circuit breaker or fuse.

SPECIFICATIONS

General Data		Model Number	CBX32MV-048	CBX32MV-060	CBX32MV-068
	Nominal cooling capacity - tons (kW)		4 (14.1)	5 (17.6)	5+ (17.6+)
	Refrigerant		R-410A	R-410A	R-410A
Connections in. (mm)	Suction (vapor) line - sweat		7/8 (22.2)	1-1/8 (28)	1-1/8 (28)
	Liquid line - sweat		3/8 (9.5)	3/8 (9.5)	3/8 (9.5)
	Condensate drain (fpt)		(2) 3/4 (19)	(2) 3/4 (19)	(2) 3/4 (19)
Indoor Coil	Net face area - ft. ² (m ²)		7.22 (0.67)	7.22 (0.67)	7.77 (0.72)
	Tube outside diameter - in. (mm)		3/8 (9.5)	3/8 (9.5)	3/8 (9.5)
	Number of rows		3	3	3
	Fins per inch (fins per m)		12 (472)	12 (472)	12 (472)
Blower Data	Wheel nominal diameter x width - in. (mm)		12 x 9 (305 x 229)	12 x 9 (305 x 229)	15 x 9 (381 x 229)
	Motor output - hp (W)		1 (746)	1 (746)	1 (746)
Filters	¹ Number and size - in.		(1) 20 x 24 x 1	(1) 20 x 24 x 1	(1) 20 x 25 x 1
	mm		508 x 610 x 25	508 x 610 x 25	508 x 635 x 25
Shipping Data - 1 Package - lbs. (kg)			212 (96)	212 (96)	244 (111)
ELECTRICAL DATA					
Voltage - phase - 60hz			208/230V-1ph	208/230V-1ph	208/230V-1ph
² Maximum overcurrent protection (unit only)			20	20	20
Minimum circuit ampacity (unit only)			11	11	11
OPTIONAL ACCESSORIES - MUST BE ORDERED EXTRA					
Down-Flow Combustible Base - Ship. weight - lbs. (kg)			34J73 - 8 (4)	34J73 - 8 (4)	82M57 - 8 (4)
Electric Heat			2.5 to 25 kW - See Electric Heat Data tables		
Horizontal Support Frame Kit - Ship. weight - lbs. (kg)			56J18 - 18 (8)	56J18 - 18 (8)	N/A
Side Return Unit Stand (Up-Flow) - Ship. weight - lbs. (kg)			45K32 - 6 (3)	45K32 - 6 (3)	N/A
SignatureStat™ Home Comfort Control	2 Heat / 2 Cool - Heat Pump		81M28	81M28	81M28
	2 Heat/2 Cool - Conventional		81M27	81M27	81M27
	1 Heat/1 Cool - Conventional or Heat Pump		81M26	81M26	81M26
Single-Point Power Source Control Box - Ship. wt. - lbs. (kg)			21H39 - 5 (2)	21H39 - 5 (2)	21H39 - 5 (2)
Wall Hanging Bracket Kit (Up-Flow) - Ship. weight - lbs. (kg)			45K30 - 3 (1)	45K30 - 3 (1)	45K30 - 3 (1)

¹ Disposable frame type filter.

² HACR type circuit breaker or fuse.

BLOWER DATA

CBX32MV-018/024 BLOWER PERFORMANCE

0 through 0.80 in. w.g. (0 through 200 Pa) External Static Pressure Range

"ADJUST" Jumper Setting	BDC3 Jumper Speed Positions															
	"HEAT" Speed								"COOL" Speed							
	1		2		3		4		1		2		3		4	
	cfm	L/s	cfm	L/s	cfm	L/s	cfm	L/s	cfm	L/s	cfm	L/s	cfm	L/s	cfm	L/s
+	715	337	855	405	1000	470	1130	535	465	220	690	325	900	425	1050	495
NORM	670	315	770	365	900	425	1035	490	425	200	620	290	825	390	950	450
-	580	275	700	330	800	375	930	440	385	180	560	265	735	345	850	400

NOTES - The effect of static pressure, filter and electric heater resistance is included in the air volumes listed.
 First stage cooling air volume is 70% of COOL speed setting. Continuous blower speed is approximately 50% of COOL speed setting.
 Lennox Harmony III™ Zone Control applications - minimum blower speed is 300 cfm (145 L/s).

CBX32MV-018/024 BLOWER MOTOR WATTS AT "+" (Plus) BDC3 SETTING ("Adjust" Jumper at "+" Setting)

BDC3 Jumper Speed Positions		Motor Watts @ Various External Static Pressures - in. wg. (Pa)									
		0 (0)	0.1 (25)	0.2 (50)	0.3 (75)	0.4 (100)	0.5 (125)	0.6 (150)	0.7 (175)	0.8 (200)	
"HEAT" Speed	Tap 1	100	113	126	142	154	172	190	206	230	
	Tap 2	155	176	197	221	237	260	278	295	310	
	Tap 3	237	260	289	305	314	337	356	373	390	
	Tap 4	338	361	379	409	433	457	447	426	406	
"COOL" Speed	Tap 1	36	47	61	71	81	95	106	118	135	
	Tap 2	89	103	118	129	143	163	177	197	207	
	Tap 3	183	198	229	248	266	290	307	327	343	
	Tap 4	266	294	315	330	349	373	390	411	401	

CBX32MV-018/024 BLOWER MOTOR WATTS AT "NORM" BDC3 SETTING ("Adjust" Jumper at NORM Setting)

BDC3 Jumper Speed Positions		Motor Watts @ Various External Static Pressures - in. wg. (Pa)									
		0 (0)	0.1 (25)	0.2 (50)	0.3 (75)	0.4 (100)	0.5 (125)	0.6 (150)	0.7 (175)	0.8 (200)	
"HEAT" Speed	Tap 1	77	96	106	123	130	150	165	178	201	
	Tap 2	118	136	154	177	189	212	224	247	265	
	Tap 3	183	198	224	248	264	284	307	321	343	
	Tap 4	264	284	300	326	343	367	385	406	390	
"COOL" Speed	Tap 1	30	41	55	62	76	86	94	106	114	
	Tap 2	71	83	101	113	125	138	156	166	185	
	Tap 3	137	158	176	199	219	238	254	273	296	
	Tap 4	211	225	249	272	295	318	331	342	367	

CBX32MV-018/024 BLOWER MOTOR WATTS AT "-" (Minus) BDC3 SETTING ("Adjust" Jumper at "-" Setting)

BDC3 Jumper Speed Positions		Motor Watts @ Various External Static Pressures - in. wg. (Pa)									
		0 (0)	0.1 (25)	0.2 (50)	0.3 (75)	0.4 (100)	0.5 (125)	0.6 (150)	0.7 (175)	0.8 (200)	
"HEAT" Speed	Tap 1	59	73	89	106	113	130	142	156	173	
	Tap 2	95	106	118	136	152	171	183	200	215	
	Tap 3	132	148	171	186	211	225	248	266	284	
	Tap 4	195	217	242	259	283	302	314	336	349	
"COOL" Speed	Tap 1	27	35	47	59	71	77	88	92	106	
	Tap 2	57	65	83	94	110	119	134	148	166	
	Tap 3	110	124	141	157	176	188	213	231	242	
	Tap 4	148	170	195	207	230	248	272	282	306	

BLOWER DATA

CBX32MV-024/030 BLOWER PERFORMANCE

0 through 0.80 in. w.g. (0 through 200 Pa) External Static Pressure Range

"ADJUST" Jumper Setting	BDC3 Jumper Speed Positions															
	"HEAT" Speed								"COOL" Speed							
	1		2		3		4		1		2		3		4	
	cfm	L/s	cfm	L/s	cfm	L/s	cfm	L/s	cfm	L/s	cfm	L/s	cfm	L/s	cfm	L/s
+	800	380	935	440	1070	505	1210	570	660	310	880	415	1100	520	1320	625
NORM	725	340	850	400	975	460	1100	520	600	285	800	380	1000	470	1200	565
-	655	310	765	360	880	415	990	470	540	255	720	340	900	425	1080	510

NOTES - The effect of static pressure, filter and electric heater resistance is included in the air volumes listed.
 First stage cooling air volume is 70% of COOL speed setting. Continuous blower speed is approximately 50% of COOL speed setting.
 Lennox Harmony III™ Zone Control applications - minimum blower speed is 300 cfm (145 L/s).

CBX32MV-024/030 BLOWER MOTOR WATTS AT "+" (Plus) BDC3 SETTING ("Adjust" Jumper at "+" Setting)

BDC3 Jumper Speed Positions	Motor Watts @ Various External Static Pressures - in. wg. (Pa)									
	0 (0)	0.1 (25)	0.2 (50)	0.3 (75)	0.4 (100)	0.5 (125)	0.6 (150)	0.7 (175)	0.8 (200)	
"HEAT" Speed	Tap 1	65	90	120	145	185	210	240	250	275
	Tap 2	95	125	150	185	230	265	310	345	365
	Tap 3	140	190	225	250	290	320	350	405	450
	Tap 4	215	250	285	315	350	390	440	480	505
"COOL" Speed	Tap 1	45	60	90	120	140	155	165	185	200
	Tap 2	80	110	135	165	205	250	285	315	335
	Tap 3	150	195	225	260	295	320	370	425	465
	Tap 4	265	315	350	400	440	485	525	555	605

CBX32MV-024/030 BLOWER MOTOR WATTS AT "NORM" BDC3 SETTING ("Adjust" Jumper at NORM Setting)

BDC3 Jumper Speed Positions	Motor Watts @ Various External Static Pressures - in. wg. (Pa)									
	0 (0)	0.1 (25)	0.2 (50)	0.3 (75)	0.4 (100)	0.5 (125)	0.6 (150)	0.7 (175)	0.8 (200)	
"HEAT" Speed	Tap 1	50	75	100	135	155	180	195	215	230
	Tap 2	80	105	130	155	200	245	265	295	310
	Tap 3	110	150	175	200	235	275	320	350	390
	Tap 4	155	205	230	270	290	325	360	405	460
"COOL" Speed	Tap 1	40	55	80	105	120	130	150	165	180
	Tap 2	65	90	120	145	190	210	240	260	285
	Tap 3	105	145	175	220	250	285	335	370	405
	Tap 4	200	245	275	300	335	385	420	470	515

CBX32MV-024/030 BLOWER MOTOR WATTS AT "-" (Minus) BDC3 SETTING ("Adjust" Jumper at "-" Setting)

BDC3 Jumper Speed Positions	Motor Watts @ Various External Static Pressures - in. wg. (Pa)									
	0 (0)	0.1 (25)	0.2 (50)	0.3 (75)	0.4 (100)	0.5 (125)	0.6 (150)	0.7 (175)	0.8 (200)	
"HEAT" Speed	Tap 1	45	65	90	110	130	150	165	190	195
	Tap 2	60	85	110	145	175	200	215	235	240
	Tap 3	85	105	130	165	210	245	280	305	330
	Tap 4	115	145	175	205	230	280	325	370	390
"COOL" Speed	Tap 1	30	50	70	90	100	115	125	140	165
	Tap 2	55	75	100	135	155	185	190	210	225
	Tap 3	85	115	135	175	210	255	295	320	345
	Tap 4	145	175	215	245	280	325	355	410	450

BLOWER DATA

CBX32MV-036 BLOWER PERFORMANCE

0 through 0.80 in. w.g. (0 through 200 Pa) External Static Pressure Range

"ADJUST" Jumper Setting	BDC3 Jumper Speed Positions															
	"HEAT" Speed								"COOL" Speed							
	1		2		3		4		1		2		3		4	
	cfm	L/s	cfm	L/s	cfm	L/s	cfm	L/s	cfm	L/s	cfm	L/s	cfm	L/s	cfm	L/s
+	1230	580	1335	630	1445	680	1545	730	1090	515	1225	580	1380	650	1545	730
NORM	1120	530	1215	575	1315	620	1400	660	975	460	1125	530	1275	600	1400	660
-	1010	475	1185	560	1200	565	1265	595	900	425	1000	470	1135	535	1265	595

NOTES - The effect of static pressure, filter and electric heater resistance is included in the air volumes listed.
 First stage cooling air volume is 65% of COOL speed setting. Continuous blower speed is approximately 50% of COOL speed setting.
 Lennox Harmony III™ Zone Control applications - minimum blower speed is 442 cfm (210 L/s).

CBX32MV-036 BLOWER MOTOR WATTS AT "+" (Plus) BDC3 SETTING ("Adjust" Jumper at "+" Setting)

BDC3 Jumper Speed Positions		Motor Watts @ Various External Static Pressures - in. wg. (Pa)								
		0 (0)	0.1 (25)	0.2 (50)	0.3 (75)	0.4 (100)	0.5 (125)	0.6 (150)	0.7 (175)	0.8 (200)
"HEAT" Speed	Tap 1	220	235	265	290	310	335	360	385	465
	Tap 2	285	305	330	355	380	405	430	450	475
	Tap 3	345	365	405	430	455	485	515	545	570
	Tap 4	470	495	515	530	545	560	575	595	610
"COOL" Speed	Tap 1	145	165	200	225	250	275	300	325	350
	Tap 2	225	245	265	290	320	350	370	395	410
	Tap 3	305	325	350	390	420	445	475	505	535
	Tap 4	470	495	515	530	545	560	575	595	610

CBX32MV-036 BLOWER MOTOR WATTS AT "NORM" BDC3 SETTING ("Adjust" Jumper at NORM Setting)

BDC3 Jumper Speed Positions		Motor Watts @ Various External Static Pressures - in. wg. (Pa)								
		0 (0)	0.1 (25)	0.2 (50)	0.3 (75)	0.4 (100)	0.5 (125)	0.6 (150)	0.7 (175)	0.8 (200)
"HEAT" Speed	Tap 1	155	185	215	240	265	285	300	335	355
	Tap 2	225	245	270	295	325	345	370	390	415
	Tap 3	275	290	315	340	375	400	420	445	465
	Tap 4	320	345	375	405	435	460	485	515	540
"COOL" Speed	Tap 1	120	140	160	190	210	230	255	275	300
	Tap 2	160	190	220	240	265	290	320	340	365
	Tap 3	255	270	295	320	345	375	400	420	445
	Tap 4	320	345	375	405	435	460	485	515	540

CBX32MV-036 BLOWER MOTOR WATTS AT "-" (Minus) BDC3 SETTING ("Adjust" Jumper at "-" Setting)

BDC3 Jumper Speed Positions		Motor Watts @ Various External Static Pressures - in. wg. (Pa)								
		0 (0)	0.1 (25)	0.2 (50)	0.3 (75)	0.4 (100)	0.5 (125)	0.6 (150)	0.7 (175)	0.8 (200)
"HEAT" Speed	Tap 1	120	135	165	185	205	225	245	265	300
	Tap 2	140	165	195	215	245	270	300	315	335
	Tap 3	185	210	240	265	285	310	330	360	385
	Tap 4	245	255	290	310	335	355	380	405	430
"COOL" Speed	Tap 1	90	110	135	155	180	195	210	230	250
	Tap 2	120	140	160	185	215	235	255	275	295
	Tap 3	160	190	225	240	275	295	320	350	380
	Tap 4	245	255	290	310	335	355	380	405	430

BLOWER DATA

CBX32MV-048 AND CBX32MV-060 BLOWER PERFORMANCE

0 through 0.80 in. w.g. (0 Through 200 Pa) External Static Pressure Range

"ADJUST" Jumper Setting	BDC3 Jumper Speed Positions															
	"HEAT" Speed								"COOL" Speed							
	1		2		3		4		1		2		3		4	
	cfm	L/s	cfm	L/s	cfm	L/s	cfm	L/s	cfm	L/s	cfm	L/s	cfm	L/s	cfm	L/s
+	1850	875	1960	925	2090	985	2150	1015	1625	765	1820	860	2055	970	2145	1010
NORM	1705	805	1800	850	1900	895	2005	945	1425	670	1625	765	1805	850	2005	945
-	1560	735	1625	765	1720	810	1770	835	1205	570	1375	650	1555	735	1725	815

NOTES - The effect of static pressure, filter and electric heater resistance is included in the air volumes listed.
 First stage cooling air volume is 60% of COOL speed setting. Continuous blower speed is approximately 50% of COOL speed setting.
 Lennox Harmony III™ Zone Control applications - minimum blower speed is 442 cfm (210 L/s).

CBX32MV-048 AND CBX32MV-060 BLOWER MOTOR WATTS AT "+" (Plus) BDC3 SETTING ("Adjust" Jumper at "+" Setting)

BDC3 Jumper Speed Positions		Motor Watts @ Various External Static Pressures - in. wg. (Pa)								
		0 (0)	0.1 (25)	0.2 (50)	0.3 (75)	0.4 (100)	0.5 (125)	0.6 (150)	0.7 (175)	0.8 (200)
"HEAT" Speed	Tap 1	455	505	540	585	630	665	710	745	780
	Tap 2	555	595	645	675	730	780	820	865	895
	Tap 3	680	720	770	820	865	900	945	985	1030
	Tap 4	730	780	825	870	920	970	1020	1055	1110
"COOL" Speed	Tap 1	300	335	370	360	435	465	500	535	575
	Tap 2	425	475	500	545	585	635	670	710	745
	Tap 3	625	660	705	755	810	850	885	940	970
	Tap 4	700	750	800	845	895	940	990	1030	1080

CBX32MV-048 AND CBX32MV-060 BLOWER MOTOR WATTS AT "NORM" BDC3 SETTING ("Adjust" Jumper at NORM Setting)

BDC3 Jumper Speed Positions		Motor Watts @ Various External Static Pressures - in. wg. (Pa)								
		0 (0)	0.1 (25)	0.2 (50)	0.3 (75)	0.4 (100)	0.5 (125)	0.6 (150)	0.7 (175)	0.8 (200)
"HEAT" Speed	Tap 1	360	385	425	465	495	525	565	600	635
	Tap 2	400	440	485	520	555	595	640	670	705
	Tap 3	480	520	560	605	640	685	765	785	805
	Tap 4	580	625	665	710	760	800	835	875	925
"COOL" Speed	Tap 1	215	235	275	295	330	360	400	430	465
	Tap 2	310	335	375	405	440	465	500	530	565
	Tap 3	415	445	490	535	565	605	650	675	715
	Tap 4	580	610	655	695	740	785	830	870	910

CBX32MV-048 AND CBX32MV-060 BLOWER MOTOR WATTS AT "-" (Minus) BDC3 SETTING ("Adjust" Jumper at "-" Setting)

BDC3 Jumper Speed Positions		Motor Watts @ Various External Static Pressures - in. wg. (Pa)								
		0 (0)	0.1 (25)	0.2 (50)	0.3 (75)	0.4 (100)	0.5 (125)	0.6 (150)	0.7 (175)	0.8 (200)
"HEAT" Speed	Tap 1	265	305	340	370	410	440	460	505	540
	Tap 2	320	350	395	420	450	475	515	545	580
	Tap 3	375	410	435	470	515	545	575	610	645
	Tap 4	400	435	480	525	555	595	640	670	700
"COOL" Speed	Tap 1	140	170	195	215	250	275	300	335	360
	Tap 2	200	230	260	285	315	355	385	415	450
	Tap 3	280	315	340	380	415	445	465	505	540
	Tap 4	375	420	440	475	515	550	575	610	645

BLOWER DATA

CBX32MV-068 BLOWER PERFORMANCE

0 through 0.80 in. w.g. (0 Through 200 Pa) External Static Pressure Range

"ADJUST" Jumper Setting	BDC3 Jumper Speed Positions															
	"HEAT" Speed								"COOL" Speed							
	1		2		3		4		1		2		3		4	
	cfm	L/s	cfm	L/s	cfm	L/s	cfm	L/s	cfm	L/s	cfm	L/s	cfm	L/s	cfm	L/s
+	1875	885	1975	930	2090	985	2150	1015	1640	775	1840	870	2075	980	2150	1015
NORM	1760	830	1825	860	1920	905	2030	960	1465	690	1625	765	1800	850	2000	945
-	1550	730	1650	780	1725	815	1800	850	1250	590	1390	655	1560	735	1720	810

NOTES - The effect of static pressure, filter and electric heater resistance is included in the air volumes listed.

First stage cooling air volume is 60% of COOL speed setting. Continuous blower speed is approximately 50% of COOL speed setting.

Lennox Harmony III™ Zone Control applications - minimum blower speed is 442 cfm (210 L/s).

CBX32MV-068 BLOWER MOTOR WATTS AT "+" (Plus) BDC3 SETTING ("Adjust" Jumper at "+" Setting)

BDC3 Jumper Speed Positions		Motor Watts @ Various External Static Pressures - in. wg. (Pa)									
		0 (0)	0.1 (25)	0.2 (50)	0.3 (75)	0.4 (100)	0.5 (125)	0.6 (150)	0.7 (175)	0.8 (200)	
"HEAT" Speed	Tap 1	365	410	455	495	545	610	660	725	790	
	Tap 2	430	485	540	590	640	690	765	835	865	
	Tap 3	540	585	635	695	750	800	815	840	865	
	Tap 4	665	710	755	770	790	810	830	845	870	
"COOL" Speed	Tap 1	255	290	320	365	415	455	505	550	590	
	Tap 2	355	390	425	475	515	580	630	695	750	
	Tap 3	505	565	610	70	715	790	815	845	865	
	Tap 4	725	745	755	770	790	810	830	850	870	

CBX32MV-068 BLOWER MOTOR WATTS AT "NORM" BDC3 SETTING ("Adjust" Jumper at NORM Setting)

BDC3 Jumper Speed Positions		Motor Watts @ Various External Static Pressures - in. wg. (Pa)									
		0 (0)	0.1 (25)	0.2 (50)	0.3 (75)	0.4 (100)	0.5 (125)	0.6 (150)	0.7 (175)	0.8 (200)	
"HEAT" Speed	Tap 1	310	345	385	425	465	510	560	610	665	
	Tap 2	345	385	420	460	500	620	615	680	735	
	Tap 3	385	430	480	525	580	640	695	750	815	
	Tap 4	475	525	560	615	660	720	785	845	810	
"COOL" Speed	Tap 1	180	205	240	285	325	365	405	435	480	
	Tap 2	250	285	320	355	410	455	505	535	585	
	Tap 3	345	375	415	460	505	560	610	670	735	
	Tap 4	445	510	560	595	665	725	790	845	865	

CBX32MV-068 BLOWER MOTOR WATTS AT "-" (Minus) BDC3 SETTING ("Adjust" Jumper at "-" Setting)

BDC3 Jumper Speed Positions		Motor Watts @ Various External Static Pressures - in. wg. (Pa)									
		0 (0)	0.1 (25)	0.2 (50)	0.3 (75)	0.4 (100)	0.5 (125)	0.6 (150)	0.7 (175)	0.8 (200)	
"HEAT" Speed	Tap 1	215	245	285	325	375	415	460	495	540	
	Tap 2	255	295	325	370	410	460	510	545	580	
	Tap 3	295	330	375	395	445	495	555	600	660	
	Tap 4	335	370	400	445	505	550	600	660	705	
"COOL" Speed	Tap 1	125	150	170	210	245	270	300	340	370	
	Tap 2	160	185	225	255	300	335	365	415	450	
	Tap 3	225	245	280	320	370	420	460	510	545	
	Tap 4	290	325	355	400	445	490	545	595	650	

CBX32MV-018/024 AND CBX32MV-024/030 - ELECTRIC HEAT DATA

SINGLE PHASE ELECTRIC HEAT

Model Number		No. of Steps	Volts Input	kW Input	1 Btuh Input	2 Blower Motor Full Load Amps	CBX32MV-018/024		CBX32MV-024/030			
							3 Minimum Circuit Ampacity	5 Maximum Overcurrent Protection	3 Minimum Circuit Ampacity		5 Maximum Overcurrent Protection	
									Circuit 1	Circuit 2	Circuit 1	Circuit 2
2.5 kW 4 lbs.	ECB29-2.5 (28K30) Terminal Block	1	208	1.9	6,400	4.3	17	15	---	---	---	---
			220	2.1	7,200	4.3	17	20	---	---	---	---
			230	2.3	7,800	4.3	18	20	---	---	---	---
			240	2.5	8,500	4.3	18	20	---	---	---	---
5 kW 4 lbs.	ECB29-5 (28K31) Terminal Block ECB29-5CB (28K32) 30A Circuit breaker	1	208	3.8	12,800	4.3	28	30	28	---	30	---
			220	4.2	14,300	4.3	31	35	31	---	35	---
			230	4.6	15,700	4.3	31	35	31	---	35	---
			240	5.0	17,100	4.3	31	35	31	---	35	---
6 kW 4 lbs.	ECB29-6 (47L22) Terminal Block ECB29-6CB (47L23) 35A Circuit breaker	1	208	4.5	15,400	4.3	32	35	32	---	35	---
			220	5.0	17,100	4.3	37	40	37	---	40	---
			230	5.5	18,800	4.3	37	40	37	---	40	---
			240	6.0	20,500	4.3	37	40	37	---	40	---
8 kW 5 lbs.	ECB29-8 (28K33) Terminal Block ECB29-8CB (28K34) 45A Circuit breaker	2	208	6.0	20,500	4.3	41	45	41	---	45	---
			220	6.7	22,900	4.3	47	50	47	---	50	---
			230	7.3	25,100	4.3	47	50	47	---	50	---
			240	8.0	27,300	4.3	47	50	47	---	50	---
9 kW 5 lbs.	ECB29-9CB (10L11) 50A Circuit breaker ECB29EH-9CB (91K67) 50A Circuit breaker	2	208	6.8	23,100	4.3	46	50	46	---	50	---
			220	7.6	25,800	4.3	52	60	52	---	60	---
			230	8.3	28,200	4.3	52	60	52	---	60	---
			240	9.0	30,700	4.3	52	60	52	---	60	---
10 kW 6 lbs.	ECB29-10 (28K35) Terminal Block ECB29-10CB (28K36) 60A Circuit breaker	2	208	7.5	25,600	4.3	51	60	---	---	---	---
			220	8.4	28,700	4.3	53	60	---	---	---	---
			230	9.2	31,400	4.3	55	60	---	---	---	---
			240	10.0	34,100	4.3	58	60	---	---	---	---
12.5 kW 10 lbs.	ECB29-12.5CB (28K37) (1) 25A & (1) 50A Circuit breaker ECB29EH-12.5CB (91K68) (1) 25A & (1) 50A Circuit breaker	3	208	9.4	32,000	4.3	---	---	24	31	25	4 45
			220	10.5	35,800	4.3	---	---	27	35	30	50
			230	11.5	39,200	4.3	---	---	27	35	30	50
			240	12.5	42,600	4.3	---	---	27	35	30	50
15 kW 12 lbs.	ECB29-15CB (28K38) (1) 30A & (1) 60A Circuit breaker ECB29EH-15CB (91K69) (1) 30A & (1) 60A Circuit breaker	3	208	11.3	38,400	4.3	---	---	28	37	30	4 50
			220	12.6	43,000	4.3	---	---	31	42	35	60
			230	13.8	47,000	4.3	---	---	31	42	35	60
			240	15.0	51,200	4.3	---	---	31	42	35	60

NOTE - Circuit 1 Minimum Circuit Ampacity includes the Blower Motor Full Load Amps.

¹ Electric heater capacity only — does not include additional blower motor heat capacity.

² Amps shown are for blower motor only.

³ Refer to National or Canadian Electrical Code manual to determine wire, fuse and disconnect size requirements. Use wires suitable for at least 167°F (75°C).

⁴ **Bold text indicates that the circuit breaker on "CB" circuit breaker models must be replaced with size noted.**

⁵ HACR type circuit breaker or fuse.

CBX32MV-036 - ELECTRIC HEAT DATA

SINGLE PHASE ELECTRIC HEAT						CBX32MV-036				
Model Number	No. of Steps	Volts Input	kW Input	1 Btuh Input	2 Blower Motor Full Load Amps	3 Minimum Circuit Ampacity		5 Maximum Overcurrent Protection		
						1	2	1	2	
5 kW 4 lbs. ECB29-5 (28K31) Terminal Block ECB29-5CB (28K32) 30A Circuit breaker	1	208	3.8	12,800	4.3	28	---	30	---	
		220	4.2	14,300	4.3	31	---	35	---	
		230	4.6	15,700	4.3	31	---	35	---	
		240	5.0	17,100	4.3	31	---	35	---	
6 kW 4 lbs. ECB29-6 (47L22) Terminal Block ECB29-6CB (47L23) 35A Circuit breaker	1	208	4.5	15,400	4.3	32	---	35	---	
		220	5.0	17,100	4.3	37	---	40	---	
		230	5.5	18,800	4.3	37	---	40	---	
		240	6.0	20,500	4.3	37	---	40	---	
8 kW 5 lbs. ECB29-8 (28K33) Terminal Block ECB29-8CB (28K34) 45A Circuit breaker	2	208	6.0	20,500	4.3	41	---	45	---	
		220	6.7	22,900	4.3	47	---	50	---	
		230	7.3	25,100	4.3	47	---	50	---	
		240	8.0	27,300	4.3	47	---	50	---	
9 kW 5 lbs. ECB299CB (10L11) 50A Circuit breaker ECB29EH-9CB (91K67) 50A Circuit breaker	2	208	6.8	23,100	4.3	46	---	50	---	
		220	7.6	25,800	4.3	52	---	60	---	
		230	8.3	28,200	4.3	52	---	60	---	
		240	9.0	30,700	4.3	52	---	60	---	
12.5 kW 10 lbs. ECB29-12.5CB (28K37) (1) 25A & (1) 50A Circuit breaker ECB29EH-12.5CB (91K68) (1) 25A & (1) 50A Circuit breaker	3	208	9.4	32,000	4.3	24	31	25	4 45	
		220	10.5	35,800	4.3	27	35	30	50	
		230	11.5	39,200	4.3	27	35	30	50	
		240	12.5	42,600	4.3	27	35	30	50	
15 kW 12 lbs. ECB29-15CB (28K38) (1) 30A & (1) 60A Circuit breaker ECB29EH-15CB (91K69) (1) 30A & (1) 60A Circuit breaker	3	208	11.3	38,400	4.3	28	37	30	4 50	
		220	12.6	43,000	4.3	31	42	35	60	
		230	13.8	47,000	4.3	31	42	35	60	
		240	15.0	51,200	4.3	31	42	35	60	
20 kW 19 lbs. ECB29-20CB (11L31) (1) 50A & (1) 60A Circuit breaker ECB29EH-20CB (91K70) (1) 50A & (1) 60A Circuit breaker	4	208	15.0	51,200	4.3	47	41	50	60	
		220	16.8	57,300	4.3	52	46	60	60	
		230	18.4	62,700	4.3	52	46	60	60	
		240	20.0	68,200	4.3	52	46	60	60	

THREE PHASE ELECTRIC HEAT

8 kW 5 lbs. ECB29-8 (28K42) Terminal Block	3	208	6.0	20,500	4.3	26	---	30	---
		220	6.7	22,900	4.3	29	---	30	---
		230	7.3	25,100	4.3	29	---	30	---
		240	8.0	27,300	4.3	29	---	30	---
10 kW 6 lbs. ECB29-10 (28K43) Terminal Block	3	208	7.5	25,600	4.3	31	---	35	---
		220	8.4	28,700	4.3	35	---	35	---
		230	9.2	31,400	4.3	35	---	35	---
		240	10.0	34,100	4.3	35	---	35	---
15 kW 12 lbs. ECB29-15CB (28K44) 50A Circuit breaker	3	208	11.3	38,400	4.3	44	---	4 45	---
		220	12.6	43,000	4.3	50	---	50	---
		230	13.5	47,000	4.3	50	---	50	---
		240	15.0	51,200	4.3	50	---	50	---
20 kW 19 lbs. ECB29-20CB (28K45) (2) 35A Circuit breaker	6	208	15.0	51,200	4.3	31	21	35	4 30
		220	16.8	57,300	4.3	35	24	35	35
		230	18.4	62,700	4.3	35	24	35	35
		240	20.0	68,200	4.3	35	24	35	35

NOTE - Circuit 1 Minimum Circuit Ampacity includes the Blower Motor Full Load Amps.

¹ Electric heater capacity only — does not include additional blower motor heat capacity.

² Amps shown are for blower motor only.

³ Refer to National or Canadian Electrical Code manual to determine wire, fuse and disconnect size requirements. Use wires suitable for at least 167°F (75°C).

⁴ **Bold text indicates that the circuit breaker on "CB" circuit breaker models must be replaced with size noted.**

⁵ HACR type circuit breaker or fuse.

CBX32MV-048, CBX32MV-060 AND CBX32MV-068 - ELECTRIC HEAT DATA

SINGLE PHASE ELECTRIC HEAT

Model Number		No. of Steps	Volts Input	kW Input	1 Btuh Input	CBX32MV-048, CBX32MV-060 and CBX32MV-068			5 Maximum Overcurrent Protection			
						2 Blower Motor Full Load Amps	3 Minimum Circuit Ampacity			Circuit 1	Circuit 2	Circuit 3
5 kW 4 lbs.	ECB29-5 (28K31) Terminal Block	1	208	3.8	12,800	9.1	34	---	---	40	---	---
	ECB29-5CB (28K32) 30A Circuit breaker		220	4.2	14,300	9.1	37	---	---	45	---	---
			230	4.6	15,700	9.1	37	---	---	45	---	---
			240	5.0	17,100	9.1	37	---	---	45	---	---
6 kW 4 lbs.	ECB29-6 (47L22) Terminal Block	1	208	4.5	15,400	9.1	36	---	---	45	---	---
	ECB29-6CB (47L23) 35A Circuit breaker		220	5.0	17,100	9.1	43	---	---	50	---	---
			230	5.5	18,800	9.1	43	---	---	50	---	---
			240	6.0	20,500	9.1	43	---	---	50	---	---
8 kW 5 lbs.	ECB29-8 (28K33) Terminal Block	2	208	6.0	20,500	9.1	47	---	---	50	---	---
	ECB29-8CB (28K34) 45A Circuit breaker		220	6.7	22,900	9.1	53	---	---	60	---	---
			230	7.3	25,100	9.1	53	---	---	60	---	---
			240	8.0	27,300	9.1	53	---	---	60	---	---
9 kW 5 lbs.	ECB29-9CB (10L11) 50A Circuit breaker	2	208	6.8	23,100	9.1	52	---	---	60	---	---
	ECB29EH-9CB (91K67) 50A Circuit breaker		220	7.6	25,800	9.1	58	---	---	60	---	---
			230	8.3	28,200	9.1	58	---	---	60	---	---
			240	9.0	30,700	9.1	58	---	---	60	---	---
12.5 kW 10 lbs.	ECB29-12.5CB (28K37) (1) 25A & (1) 50A Circuit breaker	3	208	9.4	32,000	9.1	30	31	---	⁴ 40	⁴ 45	---
	ECB29EH-12.5CB (91K68) (1) 25A & (1) 50A Circuit breaker		220	10.5	35,800	9.1	33	35	---	⁴ 45	50	---
			230	11.5	39,200	9.1	33	35	---	⁴ 45	50	---
			240	12.5	42,600	9.1	33	35	---	⁴ 45	50	---
15 kW 12 lbs.	ECB29-15CB (28K38) (1) 30A & (1) 60A Circuit breaker	3	208	11.3	38,400	9.1	34	37	---	⁴ 40	⁴ 50	---
	ECB29EH-15CB (91K69) (1) 30A & (1) 60A Circuit breaker		220	12.6	43,000	9.1	37	42	---	⁴ 45	60	---
			230	13.5	47,000	9.1	37	42	---	⁴ 45	60	---
			240	15.0	51,200	9.1	37	42	---	⁴ 45	60	---
20 kW 19 lbs.	ECB29-20CB (11L31) (1) 50A & (1) 60A Circuit breaker	4	208	15.0	51,200	9.1	53	41	---	60	60	---
	ECB29EH-20CB (91K70) (1) 50A & (1) 60A Circuit breaker		220	16.8	57,300	9.1	58	46	---	60	60	---
			230	18.4	62,700	9.1	58	46	---	60	60	---
			240	20.0	68,200	9.1	58	46	---	60	60	---
25 kW 19 lbs.	ECB29-25CB (28K40) (3) 50A Breakers	6	208	18.8	64,100	9.1	49	31	31	50	⁴ 45	⁴ 45
			220	21.0	71,700	9.1	54	35	35	60	50	50
			230	23.0	78,300	9.1	54	35	35	60	50	50
			240	25.0	85,300	9.1	54	35	35	60	50	50

THREE PHASE ELECTRIC HEAT

8 kW 5 lbs.	ECB29-8 (28K42) Terminal block	3	208	6.0	20,500	9.1	32	---	---	40	---	---
			220	6.7	22,900	9.1	35	---	---	40	---	---
			230	7.3	25,100	9.1	35	---	---	40	---	---
			240	8.0	27,300	9.1	35	---	---	40	---	---
10 kW 6 lbs.	ECB29-10 (28K43) Terminal block	3	208	7.5	25,600	9.1	37	---	---	45	---	---
			220	8.4	28,700	9.1	41	---	---	50	---	---
			230	9.2	31,400	9.1	41	---	---	50	---	---
			240	10.0	34,100	9.1	41	---	---	50	---	---
15 kW 12 lbs.	ECB29-15CB (28K44) 50A Circuit breaker	3	208	11.3	38,400	9.1	50	---	---	60	---	---
			220	12.6	43,000	9.1	56	---	---	60	---	---
			230	13.5	47,000	9.1	56	---	---	60	---	---
			240	15.0	51,200	9.1	56	---	---	60	---	---
20 kW 19 lbs.	ECB29-20CB (28K45) (2) 35A Circuit breakers	6	208	15.0	51,200	9.1	37	21	---	⁴ 45	⁴ 30	---
			220	16.8	57,300	9.1	41	24	---	⁴ 50	35	---
			230	18.4	62,700	9.1	41	24	---	⁴ 50	35	---
			240	20.0	68,200	9.1	41	24	---	⁴ 50	35	---
25 kW 19 lbs.	ECB29-25CB (28K46) (2) 45A Circuit breakers	6	208	18.8	64,100	9.1	44	27	---	50	⁴ 40	---
			220	21.0	71,700	9.1	49	30	---	⁴ 60	45	---
			230	23.0	78,300	9.1	49	30	---	⁴ 60	45	---
			240	25.0	85,300	9.1	49	30	---	⁴ 60	45	---

NOTE - Circuit 1 Minimum Circuit Ampacity includes the Blower Motor Full Load Amps.

¹ Electric heater capacity only — does not include additional blower motor heat capacity.

² Amps shown are for blower motor only.

³ Refer to National or Canadian Electrical Code manual to determine wire, fuse and disconnect size requirements. Use wires suitable for at least 167°F (75°C).

⁴ Bold text indicates that the circuit breaker on "CB" circuit breaker models must be replaced with size noted.

⁵ HACR type circuit breaker or fuse.

DIMENSIONS - INCHES (MM)

UP-FLOW POSITION

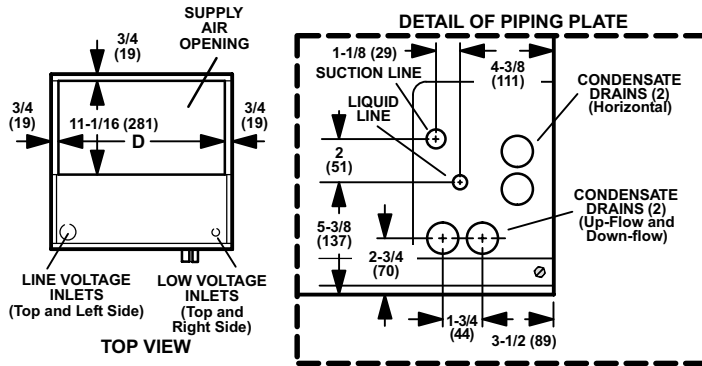

Model No.	CBX32MV -018/024		CBX32MV -024/030		CBX32MV -036		CBX32MV -048 -060		CBX32MV -068	
	inch	mm	inch	mm	inch	mm	inch	mm	inch	mm
A	45-1/4	1149	49-1/4	1251	51	1295	58-1/2	1486	64	1626
B	16-1/4	413	21-1/4	540	21-1/4	540	21-1/4	540	21-1/4	540
C	20-5/8	524	20-5/8	524	22-5/8	575	24-5/8	625	26-5/8	676
D	14-3/4	375	19-3/4	502	19-3/4	502	19-3/4	502	19-3/4	502
E	19	483	19	483	21	533	23	584	25	635
F	15	381	20	508	20	508	20	508	20	508
G	24-5/8	625	24-5/8	625	26-3/8	670	27-7/8	708	31-3/8	797
H	20-5/8	524	24-5/8	625	24-5/8	625	30-5/8	778	32-5/8	829

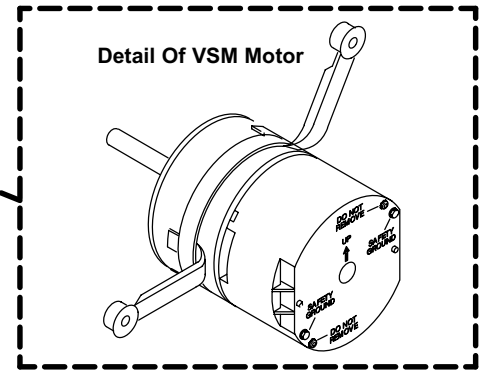
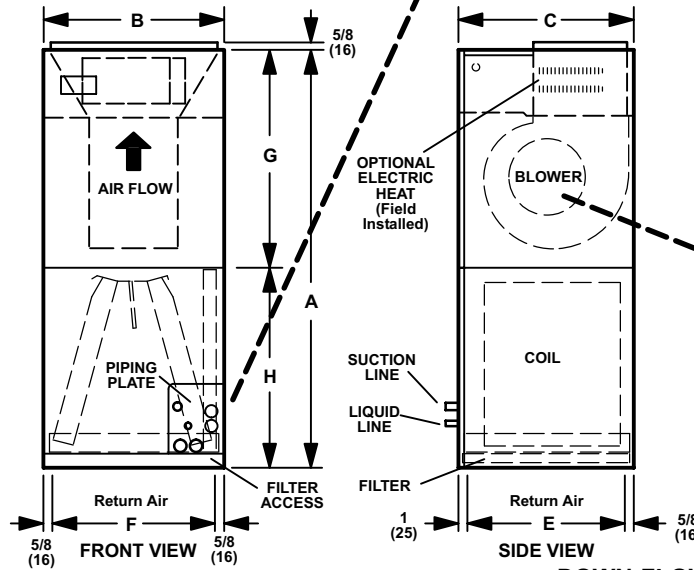

DOWN-FLOW POSITION

Model No.	CBX32MV -018/024		CBX32MV -024/030		CBX32MV -036		CBX32MV -048 -060		CBX32MV -068	
	inch	mm	inch	mm	inch	mm	inch	mm	inch	mm
A	45-1/4	1149	49-1/4	1251	51	1295	58-1/2	1486	64	1626
B	16-1/4	413	21-1/4	540	21-1/4	540	21-1/4	540	21-1/4	540
C	20-5/8	524	20-5/8	524	22-5/8	575	24-5/8	625	26-5/8	676
D	14-3/4	375	19-3/4	502	19-3/4	502	19-3/4	502	19-3/4	502
E	19	483	19	483	21	533	23	584	25	635
F	15	381	20	508	20	508	20	508	20	508
G	24-5/8	625	24-5/8	625	26-3/8	670	27-7/8	708	31-3/8	797
H	20-5/8	524	24-5/8	625	24-5/8	625	30-5/8	778	32-5/8	829

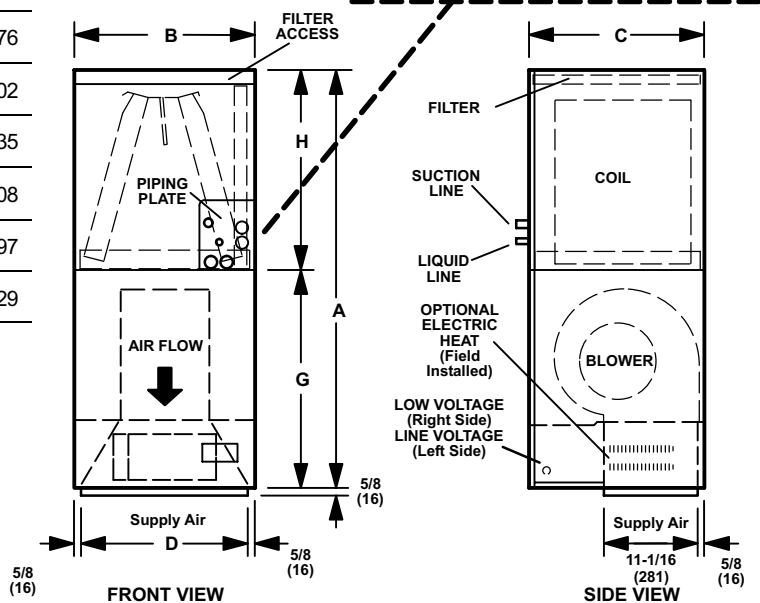
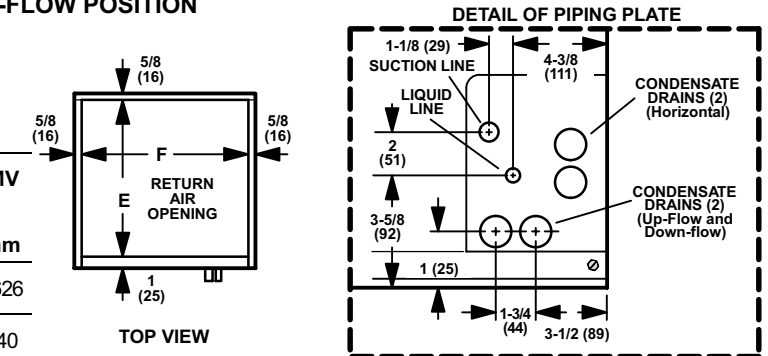

DIMENSIONS - INCHES (MM)

HORIZONTAL POSITION (RIGHT-HAND AIR DISCHARGE)

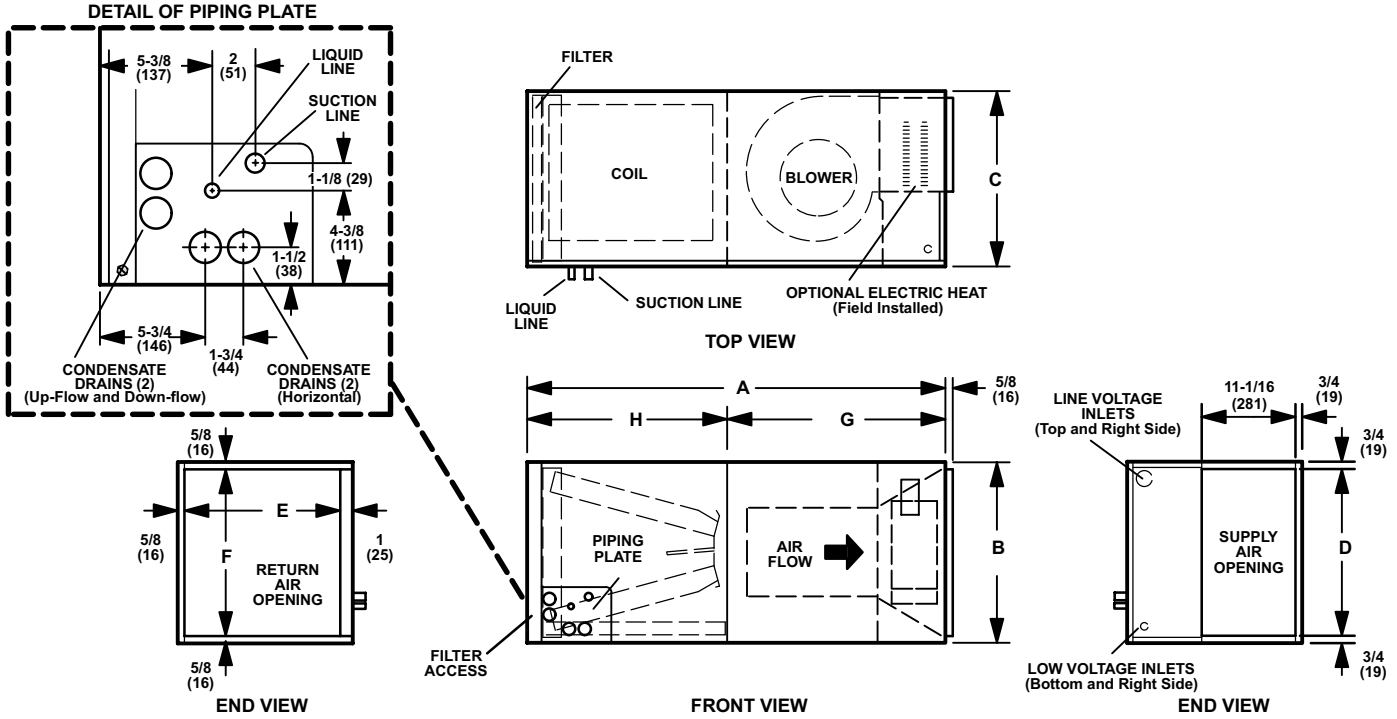

HORIZONTAL POSITION (LEFT-HAND AIR DISCHARGE)

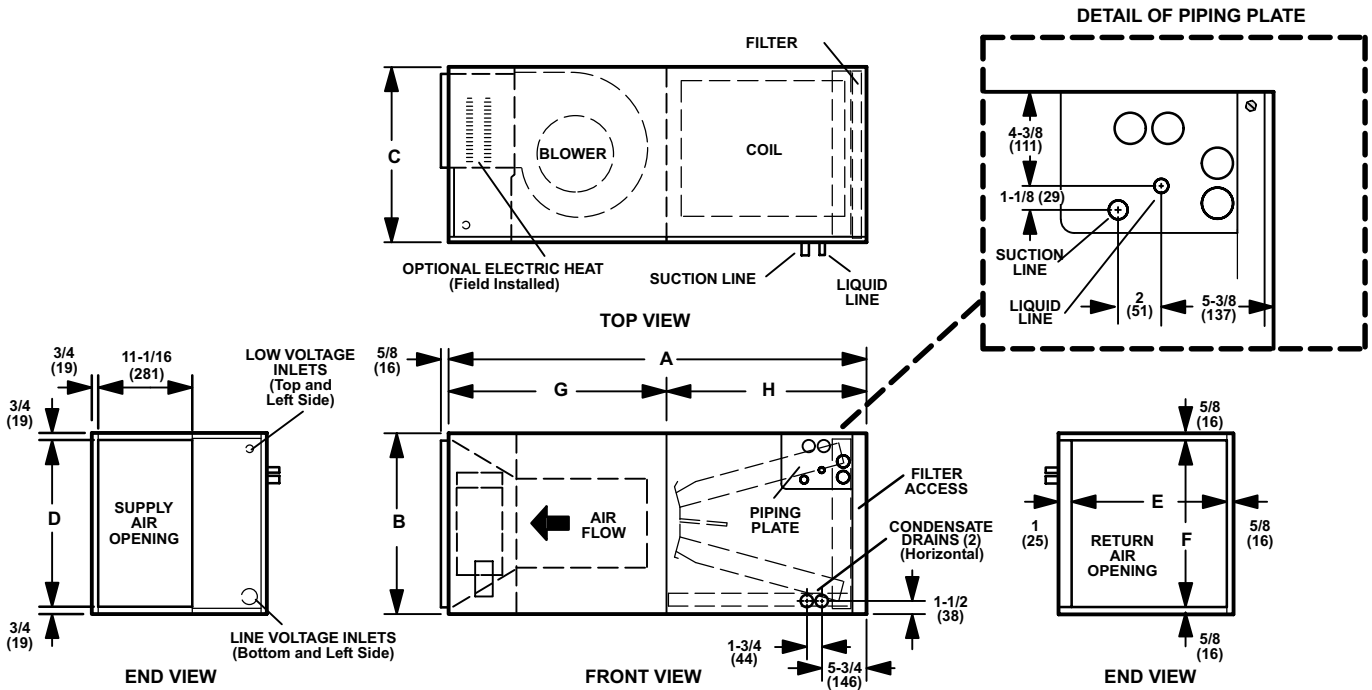

Model No.	A		B		C		D		E		F		G		H	
	inch	mm	inch	mm	inch	mm	inch	mm	inch	mm	inch	mm	inch	mm	inch	mm
CBX32MV-018/024	45-1/4	1149	16-1/4	413	20-5/8	524	14-3/4	375	19	483	15	381	24-5/8	625	20-5/8	524
CBX32MV-024/030	49-1/4	1251	21-1/4	540	20-5/8	524	19-3/4	502	19	483	20	508	24-5/8	625	24-5/8	625
CBX32MV-036	51	1295	21-1/4	540	22-5/8	575	19-3/4	502	21	533	20	508	26-3/8	670	24-5/8	625
CBX32MV-048 CBX32MV-060	58-1/2	1486	21-1/4	540	24-5/8	625	19-3/4	502	23	584	20	508	27-7/8	708	30-5/8	778
CBX32MV-068	64	1626	21-1/4	540	26-5/8	676	19-3/4	502	25	635	20	508	31-3/8	797	32-5/8	829

DIMENSIONS - INCHES (MM)

DOWN-FLOW COMBUSTIBLE FLOOR BASE

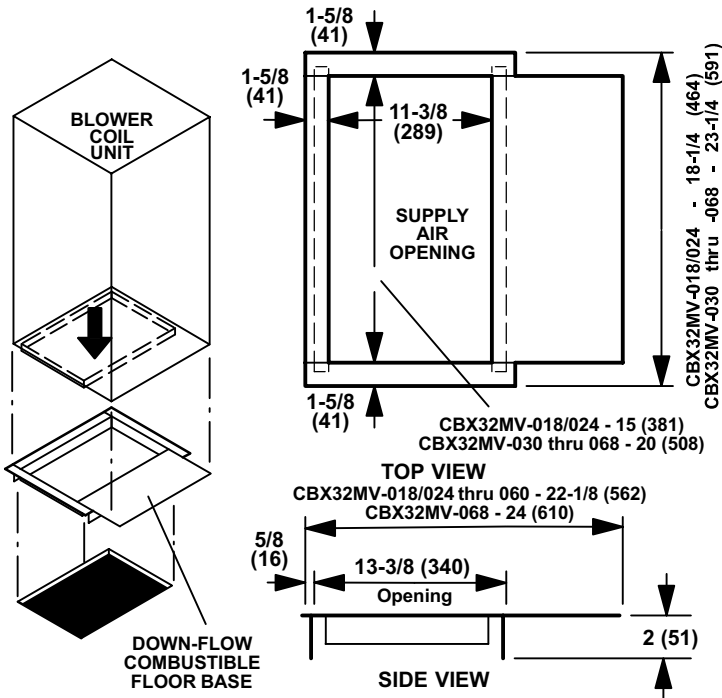

SIDE RETURN UNIT STAND (Up-Flow Only)

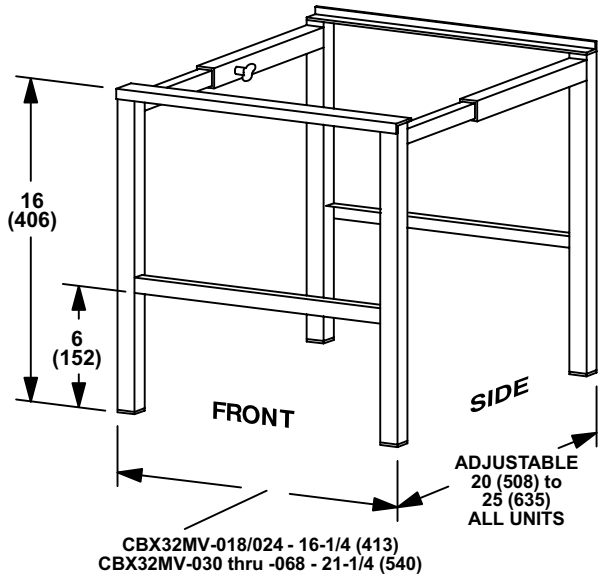

AIR FLOW

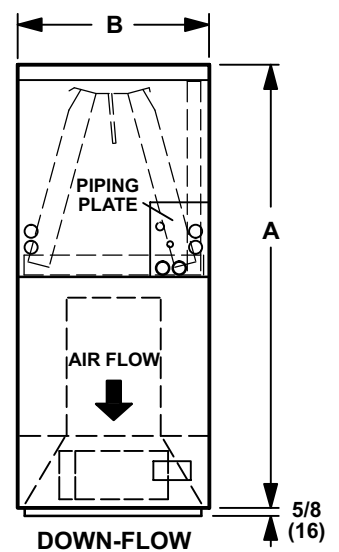
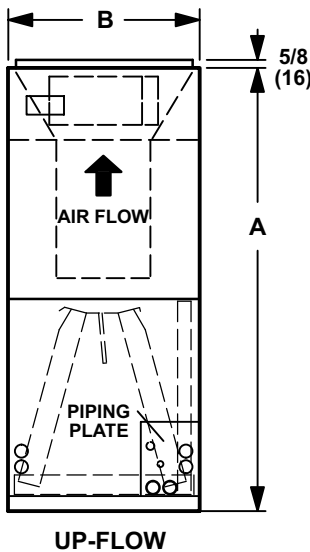
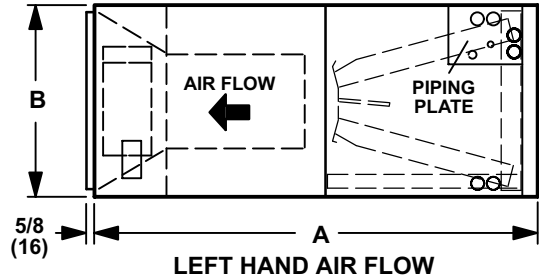
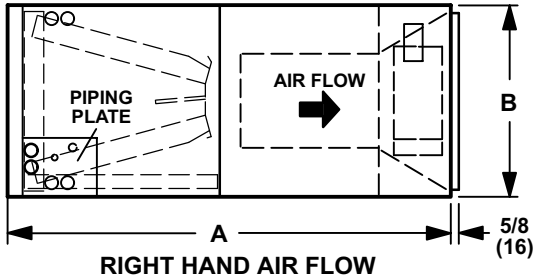

Blower Coil Model No.	A		B	
	in.	mm	in.	mm
CBX32MV-018/024	45-1/4	1149	16-1/4	413
CBX32MV-024/030	49-1/4	1251	21-1/4	540
CBX32MV-036	51	1295	21-1/4	540
CBX32MV-048 CBX32MV-060	58-1/2	1486	21-1/4	540
CBX32MV-068	64	1626	21-1/4	540



Visit us at www.lennox.com
For the latest technical information, www.lennox.com
Contact us at 1-800-4-LENNOX

NOTE - Due to Lennox' ongoing commitment to quality, Specifications, Ratings and Dimensions subject to change without notice and without incurring liability. Improper installation, adjustment, alteration, service or maintenance can cause property damage or personal injury. Installation and service must be performed by a qualified installer and servicing agency.

©2005 Lennox Industries Inc.