



Air Conditioning & Heating

PRODUCT SPECIFICATIONS



13 SEER

2- TO 5-TON

COOLING CAPACITY: 24,000 - 56,500 BTU/H

HEATING CAPACITY: 22,000 - 55,000 BTU/H

GPH13M

PACKAGED HEAT PUMP

The Goodman® GPH13M 13 SEER Packaged Heat Pump provides energy-efficient cooling and heating performance in one self-contained unit. The GPH13M is housed in a heavy-gauge, galvanized-steel cabinet that offers a high-quality, UV-resistant powder-paint finish and allows for a ground-level or rooftop mount.

Standard Features

- Energy-efficient compressor with internal relief valve
- PSC blower motor; EEM blower motor on 4- & 5-ton units
- Convertible airflow — horizontal or downflow
- Copper tube/aluminum fin coils
- Totally enclosed, permanently lubricated condenser fan motor
- Fully charged R-22 system
- Electric heat kit available as a field-installed option

Cabinet Features

- Heavy-gauge galvanized-steel cabinet with attractive Architectural Gray powder-paint finish
- Fully insulated air-handling compartment with convenient access panels
- Louvered condenser coil protection
- One footprint; two heights

Contents

Nomenclature.....	2
Product Specifications.....	3
Evaporator Blower Specifications.....	4
Expanded Cooling Data.....	6
Cooling Data Summary.....	16
Expanded Heating Data.....	18
Heat Kit Electrical Data.....	20
Dimensions.....	21
Wiring Diagrams	22
Accessories	24



NOMENCLATURE

	G	P	H	13	36	H	2	1	A	*					
	1	2	3	4,5	6,7	8	9	10	11	12					
Brand	G Goodman or Distinctions™										Engineering				
											Minor Revision				
Product Category	P Packaged Unit										Engineering				
											Major Revision				
Type	H Heat Pump		C Air Conditioner										Voltage Designator		
													1 208-230/1/60		
													3 208-230/3/60		
													4 460/3/60		
Efficiency	13 13 SEER 15 15 SEER		14 14 SEER 16 16 SEER										Refrigerant		
													2 R-22		
													4 R-410A		
Nominal Capacity	24 2 Tons 42 3½ Tons		30 2½ tons 48 4 Tons		36 3 Tons 60 5 Tons										Configuration
															H Horizontal
															M Multi-position

SPECIFICATIONS

	GPH13 24M21**	GPH13 30M21**	GPH13 36M21**	GPH13 48M21**	GPH13 60M21**
Cooling Capacity					
Total BTU/h	24,000	30,000	35,600	48,000	56,500
Sensible BTU/h	18,200	23,000	26,800	36,600	42,800
SEER / EER	13 / 11.3	13 / 11.0	13 / 11.3	13 / 11.3	13 / 10.4
Decibels	77	77	77	78	78
Heating Capacity					
BUT/h (47°F)	22,000	29,200	34,200	45,000	55,000
C.O.P (47°F)	3.4	3.2	3.4	3.5	3.4
BUT/h (17°F)	12,400	15,600	18,600	25,000	31,000
C.O.P (17°F)	2.1	2.1	2.1	2.2	2.1
HSPF	7.7	7.7	7.8	8.0	7.7
Evaporator Motor					
Type	DD	DD	DD	DD	DD
Nominal Cooling CFM	10 x 9	10 x 9	10 x 9	10 x 9	10 x 9
Wheel (DxW)	875	1,050	1,225	1,750	1,900
RLA/LRA	1.5 / 2.13	1.5 / 3.2	1.9 / 3.5	5.8 / --	7.6 / --
No. of Speeds	3	3	4	5	5
Horsepower - RPM	¼ – 1,075	½ – 1,075	⅓ – 1,075	¾ - 1,075	1 - 1,075
Evaporator Coil					
Face Area (ft ²)	4.5	4.5	4.5	6.2	6.2
Rows Deep/ Fin per Inch	3 / 14	3 / 14	4 / 14	4 / 14	4 / 14
Drain Size (NPT)	¾"	¾"	¾"	¾"	¾"
Refrigerant Charge (oz.)	108	137	165	192	195
Condenser Fan / Coil					
Horsepower - RPM	¼ – 1,075	¼ – 1,075	¼ – 1,075	⅓ – 1,075	⅓ – 1,075
RLA/LRA	1.5 / 3.0	1.5 / 3.0	1.5 / 3.0	2.4 / 5.2	2.4 / 5.2
Fan Diameter / # Fan Blades	22 / 3	22" / 3	22 / 3	22 / 4	22 / 4
Face Area (ft ²)	17.2	15.9	17.2	21.2	21.2
Rows Deep/ Fin per Inch	1 / 19	2 / 16	2 / 16	2 / 16	2 / 18
Electrical Data					
Voltage/ Phase/ Frequency	208-230/1/60	208-230/1/60	208-230/1/60	208-230/1/60	208-230/1/60
Compressor RLA/ LRA	10.9 / 54	13.5 / 73	14.7 / 83	18.3 / 109	25.0 / 148
Total Unit Amps	13.9	12.3	18.1	26.6	35.1
Min. Circuit Ampacity ¹	16.6	19.9	21.7	31.2	41.4
Max. Overcurrent Protection ²	20 amps	30 amps	30 amps	40 amps	60 amps
Shipping Weight (lbs)	376	410	438	492	523

¹ Wire size should be determined in accordance with National Electrical Codes. Extensive wire runs will require larger wire sizes.

² May use fuses or HACR-type circuit breakers of the same size as noted.

Note: Always check the S&R plate for electrical data on the unit being installed.

EVAPORATOR BLOWER SPECIFICATIONS

Model	Speed	Volts		E.S.P (In. of H ₂ O)							
				0.1	0.2	0.3	0.4	0.5	0.6	0.7	0.8
GPH13 24M21A	Low	230	CFM	685	635	-	-	-	-	-	-
			Watts	155	150	-	-	-	-	-	-
	Med	230	CFM	965	920	870	810	745	-	-	-
			Watts	240	235	230	225	215	-	-	-
	High	230	CFM	1,320	1,290	1,240	1,180	1,115	1,040	950	820
			Watts	390	380	370	360	350	340	325	305
GPH13 30M21A	Low	230	CFM	1,185	1,155	1,077	1,015	970	881	709	601
			Watts	333	323	314	306	296	283	263	251
	Med	230	CFM	1,335	1,291	1,224	1,158	1,092	1,012	908	778
			Watts	388	378	367	358	347	334	314	299
	High	230	CFM	1,535	1,478	1,408	1,331	1,250	1,177	1,074	962
			Watts	478	474	463	449	435	422	409	393
GPH13 36M21A	Low	230	CFM	1,055	1,015	975	895	840	770	-	-
			Watts	315	310	300	285	270	255	-	-
	M / L	230	CFM	1,285	1,240	1,190	1,120	1,040	950	850	-
			Watts	385	375	365	350	335	315	295	-
	M / H	230	CFM	1,470	1,425	1,345	1,285	1,195	1,085	980	865
			Watts	455	440	425	410	385	370	350	325
	High	230	CFM	1,565	1,510	1,415	1,340	1,260	1,135	1,035	885
			Watts	495	480	460	445	425	405	385	355
GPH13 48M21A	T1 (G)	230	CFM	1,140	1,395	1,360	1,310	1,265	1,235	1,190	1,130
			Watts	275	285	295	315	325	335	345	355
	T2 / T3 (W2)	230	CFM	1,795	1,765	1,715	1,695	1,650	1,600	1,500	1,375
			Watts	475	490	505	520	530	535	510	475
	T4 / T5 Y	230	CFM	1,860	1,820	1,785	1,745	1,700	1,625	1,515	1,395
			Watts	515	530	545	565	570	550	535	485
GPH13 60M21A	T1 (G)	230	CFM	1,755	1,720	1,685	1,645	1,615	1,570	1,530	1,465
			Watts	420	435	455	460	475	490	500	500
	T2 / T3 (W2)	230	CFM	1,850	1,820	1,775	1,735	1,705	1,675	1,610	1,495
			Watts	480	500	515	525	535	555	545	520
	T4 / T5 Y	230	CFM	2,180	2,125	2,050	1,975	1,875	1,800	1,655	1,530
			Watts	770	755	725	700	675	640	575	540

Notes:

- Data shown is dry coil. Wet coil pressure drop is approximately 0.1" H₂O, for two-row indoor coil; 0.2" H₂O, for three-row indoor coil; and 0.3" H₂O, for four-row indoor coil.
- Data shown does not include filter pressure drop, approximately 0.08" H₂O.
- ALL MODELS SHOULD RUN NO LESS THAN 350 CFM/TON. USE HIGHER SPEED TAP OR NEXT SIZE LARGER BLOWER ASM. See Repair Parts list.
- Reduce airflow by 2% for 208-volt operation.

EVAPORATOR BLOWER SPECIFICATIONS (CONT.)

BTU OUTPUT vs TEMPERATURE RISE CHART

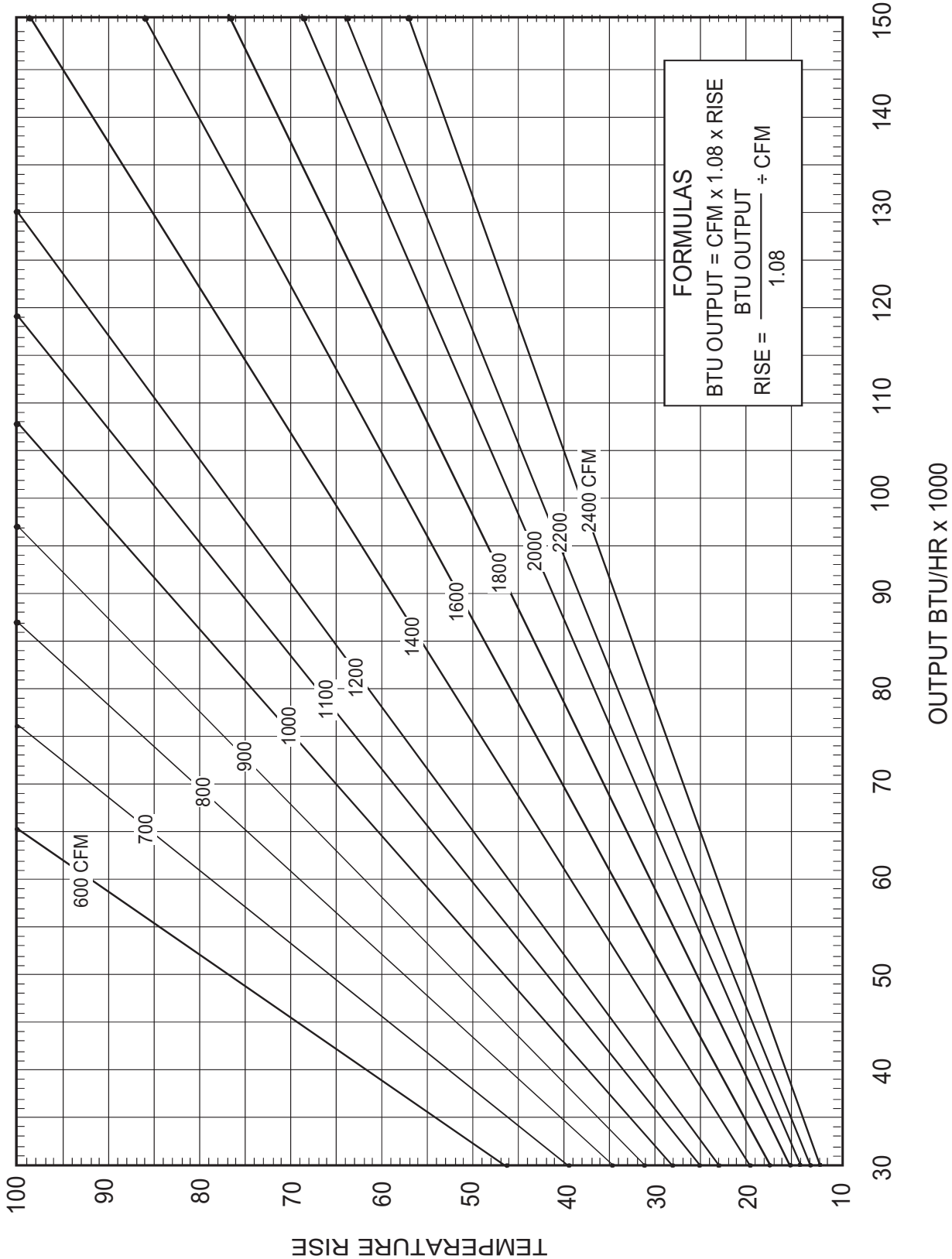

EXPANDED COOLING DATA — GPH1324M21A

IDB	Airflow	Outdoor Ambient Temperature																							
		65°F				75°F				85°F				95°F				105°F				115°F			
		59	63	67	71	59	63	67	71	59	63	67	71	59	63	67	71	59	63	67	71	59	63	67	71
1013	MBh	23.5	24.4	26.7	-	23.0	23.8	26.1	-	22.4	23.2	25.5	-	21.9	22.7	24.8	-	20.8	21.5	23.6	-	19.3	20.0	21.9	-
	S/T	0.76	0.64	0.44	-	0.79	0.66	0.46	-	0.81	0.68	0.47	-	0.84	0.70	0.48	-	0.87	0.72	0.50	-	0.87	0.73	0.51	-
	ΔT	16	14	11	-	16	14	11	-	16	14	11	-	17	14	11	-	16	14	11	-	15	13	10	-
	kW	1.78	1.81	1.86	-	1.90	1.93	1.99	-	2.00	2.04	2.10	-	2.09	2.13	2.20	-	2.17	2.22	2.28	-	2.24	2.28	2.35	-
	Amps	7.1	7.2	7.4	-	7.5	7.7	7.9	-	8.1	8.3	8.5	-	8.6	8.8	9.0	-	9.1	9.3	9.5	-	9.5	9.8	10.0	-
	Hi PR	141	152	160	-	158	170	180	-	180	193	204	-	205	220	233	-	230	248	262	-	254	274	289	-
	Lo PR	64	68	74	-	67	71	78	-	70	74	81	-	73	78	85	-	77	82	89	-	79	85	92	-
	MBh	22.8	23.7	25.9	-	22.3	23.1	25.3	-	21.8	22.6	24.7	-	21.2	22.0	24.1	-	20.2	20.9	22.9	-	18.7	19.4	21.2	-
	S/T	0.73	0.61	0.42	-	0.75	0.63	0.44	-	0.77	0.64	0.45	-	0.80	0.67	0.46	-	0.83	0.69	0.48	-	0.83	0.70	0.48	-
	ΔT	17	15	11	-	17	15	11	-	17	15	11	-	17	15	11	-	17	15	11	-	16	14	10	-
70	kW	1.77	1.80	1.85	-	1.88	1.92	1.97	-	1.99	2.03	2.08	-	2.08	2.12	2.18	-	2.16	2.20	2.26	-	2.22	2.27	2.34	-
	Amps	7.0	7.2	7.3	-	7.5	7.6	7.9	-	8.0	8.2	8.4	-	8.5	8.7	9.0	-	9.0	9.2	9.5	-	9.5	9.7	10.0	-
	Hi PR	139	150	158	-	156	168	178	-	178	191	202	-	203	218	230	-	228	245	259	-	252	271	286	-
	Lo PR	63	67	73	-	66	71	77	-	69	73	80	-	73	77	84	-	76	81	88	-	79	84	91	-
	MBh	21.1	21.8	23.9	-	20.6	21.3	23.4	-	20.1	20.8	22.8	-	19.6	20.3	22.3	-	18.6	19.3	21.1	-	17.3	17.9	19.6	-
	S/T	0.70	0.58	0.41	-	0.73	0.61	0.42	-	0.74	0.62	0.43	-	0.77	0.64	0.44	-	0.80	0.67	0.46	-	0.80	0.67	0.47	-
	ΔT	17	15	11	-	17	15	11	-	17	15	11	-	18	15	12	-	17	15	11	-	16	14	11	-
	kW	1.73	1.76	1.81	-	1.84	1.88	1.93	-	1.94	1.98	2.04	-	2.03	2.07	2.13	-	2.11	2.15	2.21	-	2.17	2.22	2.28	-
	Amps	6.9	7.0	7.2	-	7.3	7.5	7.7	-	7.8	8.0	8.2	-	8.3	8.5	8.7	-	8.8	9.0	9.2	-	9.2	9.4	9.7	-
	Hi PR	135	146	154	-	152	163	172	-	173	186	196	-	197	212	223	-	221	238	251	-	244	263	278	-
Lo PR	61	65	71	-	64	69	75	-	67	71	78	-	70	75	82	-	74	78	86	-	76	81	89	-	

1013	MBh	23.9	24.6	26.7	28.6	23.4	24.1	26.0	27.9	22.8	23.5	25.4	27.3	22.2	22.9	24.8	26.6	21.1	21.8	23.6	25.3	19.6	20.2	21.8	23.4
	S/T	0.87	0.77	0.59	0.38	0.90	0.80	0.61	0.39	0.92	0.82	0.62	0.40	0.95	0.85	0.64	0.41	0.99	0.88	0.67	0.43	0.99	0.89	0.67	0.43
	ΔT	19	17	14	10	19	18	14	10	19	18	14	10	19	18	14	10	19	17	14	10	18	16	13	9
	kW	1.79	1.82	1.87	1.93	1.91	1.95	2.00	2.06	2.02	2.05	2.11	2.18	2.11	2.15	2.21	2.28	2.19	2.23	2.30	2.37	2.26	2.30	2.37	2.44
	Amps	7.1	7.3	7.5	7.7	7.6	7.8	8.0	8.2	8.2	8.3	8.6	8.9	8.7	8.8	9.1	9.4	9.1	9.3	9.6	9.9	9.6	9.8	10.1	10.5
	Hi PR	142	153	162	169	160	172	181	189	182	195	206	215	207	223	235	245	233	250	264	276	257	277	292	305
	Lo PR	64	68	75	79	68	72	79	84	70	75	82	87	74	79	86	92	78	83	90	96	80	85	93	99
	MBh	23.2	23.9	25.9	27.8	22.7	23.4	25.3	27.1	22.1	22.8	24.7	26.5	21.6	22.2	24.1	25.8	20.5	21.1	22.9	24.5	19.0	19.6	21.2	22.7
	S/T	0.83	0.74	0.56	0.36	0.86	0.77	0.58	0.37	0.88	0.78	0.59	0.38	0.91	0.81	0.61	0.39	0.94	0.84	0.64	0.41	0.95	0.85	0.64	0.41
	ΔT	20	18	15	10	20	18	15	10	20	18	15	10	20	18	15	10	20	18	15	10	18	17	14	10
75	kW	1.78	1.81	1.86	1.91	1.90	1.93	1.99	2.04	2.00	2.04	2.10	2.16	2.09	2.13	2.20	2.26	2.17	2.22	2.28	2.35	2.24	2.29	2.35	2.43
	Amps	7.1	7.2	7.4	7.6	7.5	7.7	7.9	8.2	8.1	8.3	8.5	8.8	8.6	8.8	9.0	9.3	9.1	9.3	9.5	9.9	9.5	9.8	10.0	10.4
	Hi PR	141	152	160	167	158	170	180	187	180	193	204	213	205	220	233	243	230	248	262	273	254	274	289	302
	Lo PR	64	68	74	79	67	71	78	83	70	74	81	86	73	78	85	91	77	82	89	95	79	85	92	98
	MBh	21.4	22.1	23.9	25.6	20.9	21.6	23.3	25.0	20.4	21.0	22.8	24.4	19.9	20.5	22.2	23.8	18.9	19.5	21.1	22.7	17.5	18.1	19.6	21.0
	S/T	0.80	0.71	0.54	0.35	0.82	0.74	0.56	0.36	0.85	0.76	0.57	0.37	0.87	0.78	0.59	0.38	0.91	0.81	0.61	0.39	0.91	0.82	0.62	0.40
	ΔT	20	18	15	10	20	19	15	11	20	19	15	11	20	19	15	11	20	18	15	10	19	17	14	10
	kW	1.74	1.77	1.82	1.87	1.86	1.89	1.94	2.00	1.96	2.00	2.05	2.11	2.05	2.09	2.15	2.21	2.12	2.17	2.23	2.30	2.19	2.23	2.30	2.37
	Amps	6.9	7.0	7.2	7.5	7.4	7.5	7.7	8.0	7.9	8.1	8.3	8.6	8.4	8.6	8.8	9.1	8.8	9.0	9.3	9.6	9.3	9.5	9.8	10.1
	Hi PR	137	147	155	162	153	165	174	182	174	188	198	207	199	214	226	235	223	240	254	265	247	266	281	293
Lo PR	62	66	72	76	65	69	76	81	68	72	79	84	71	76	83	88	75	79	87	92	77	82	90	95	

Shaded area reflects ACOA (TVA) conditions IDB: Entering Indoor Dry Bulb Temperature kW = Total system power Amps = outdoor unit amps (comp.+fan)
 High and low pressures are measured at the liquid and suction service valves.

EXPANDED COOLING DATA — GPH1324M21A (CONT.)

IDB	Airflow	Outdoor Ambient Temperature																								
		65°F				75°F				85°F				95°F				105°F				115°F				
		59	63	67	71	59	63	67	71	59	63	67	71	59	63	67	71	59	63	67	71	59	63	67	71	
80	1013	MBh	24.3	24.9	26.6	28.4	23.8	24.3	26.0	27.7	23.2	23.7	25.3	27.1	22.6	23.1	24.7	26.4	21.5	22.0	23.5	25.1	19.9	20.4	21.8	23.3
		S/T	0.95	0.89	0.72	0.54	1.00	0.92	0.75	0.56	1.00	0.95	0.77	0.58	1.00	1.00	0.79	0.59	1.00	1.00	0.82	0.62	1.00	1.00	0.83	0.62
		ΔT	21	20	17	14	22	20	18	14	21	20	18	14	21	21	18	14	20	20	18	14	18	18	16	13
		kW	1.80	1.84	1.89	1.94	1.92	1.96	2.02	2.07	2.03	2.07	2.13	2.19	2.12	2.17	2.23	2.30	2.21	2.25	2.32	2.39	2.27	2.32	2.39	2.46
		Amps	7.2	7.3	7.5	7.8	7.7	7.8	8.0	8.3	8.2	8.4	8.7	8.9	8.7	8.9	9.2	9.5	9.2	9.4	9.7	10.0	9.7	9.9	10.2	10.6
	Hi PR	144	155	163	170	161	174	183	191	183	197	208	217	209	225	237	248	235	253	267	279	260	279	295	308	
	Lo PR	65	69	75	80	69	73	80	85	71	76	83	88	75	80	87	93	78	83	91	97	81	86	94	100	
	MBh	23.6	24.1	25.8	27.6	23.1	23.6	25.2	26.9	22.5	23.0	24.6	26.3	22.0	22.5	##	25.7	20.9	21.3	22.8	24.4	19.3	19.8	21.1	22.6	
	S/T	0.91	0.85	0.69	0.52	0.94	0.88	0.72	0.54	0.96	0.90	0.73	0.55	0.99	0.93	0.76	0.57	1.00	0.97	0.79	0.59	1.00	0.97	0.79	0.59	
	ΔT	22	21	18	15	22	21	18	15	22	21	18	15	22	21	19	15	21	21	18	15	20	20	17	14	
kW	1.79	1.82	1.87	1.93	1.91	1.95	2.00	2.06	2.02	2.06	2.11	2.18	2.11	2.15	2.21	2.28	2.19	2.23	2.30	2.37	2.26	2.30	2.37	2.44		
Amps	7.1	7.3	7.5	7.7	7.6	7.8	8.0	8.2	8.2	8.3	8.6	8.9	8.7	8.8	9.1	9.4	9.1	9.3	9.6	9.9	9.6	9.8	10.1	10.5		
Hi PR	142	153	162	169	160	172	181	189	182	195	206	215	207	223	235	245	233	250	264	276	257	277	292	305		
Lo PR	64	68	75	79	68	72	79	84	70	75	82	87	74	79	86	92	78	83	90	96	80	85	93	99		
MBh	21.8	22.3	23.8	25.5	21.3	21.8	23.3	24.9	20.8	21.3	22.7	24.3	20.3	20.7	22.2	23.7	19.3	19.7	21.0	22.5	17.9	18.2	19.5	20.8		
S/T	0.87	0.82	0.67	0.50	0.90	0.85	0.69	0.52	0.93	0.87	0.71	0.53	0.96	0.90	0.73	0.55	0.99	0.93	0.76	0.57	1.00	0.94	0.76	0.57		
ΔT	22	21	19	15	23	22	19	15	23	22	19	15	23	22	19	15	22	21	19	15	21	20	17	14		
kW	1.75	1.79	1.83	1.89	1.87	1.90	1.96	2.01	1.97	2.01	2.07	2.13	2.06	2.10	2.16	2.23	2.14	2.18	2.25	2.31	2.21	2.25	2.32	2.39		
Amps	7.0	7.1	7.3	7.5	7.4	7.6	7.8	8.0	8.0	8.1	8.4	8.6	8.4	8.6	8.9	9.2	8.9	9.1	9.4	9.7	9.4	9.6	9.9	10.2		
Hi PR	138	149	157	164	155	167	176	184	176	190	200	209	201	216	228	238	226	243	256	267	249	268	283	296		
Lo PR	62	66	72	77	66	70	76	81	68	73	79	85	72	76	83	89	75	80	87	93	78	83	90	96		

85	1013	MBh	24.8	25.2	26.4	28.2	24.2	24.7	25.8	27.6	23.6	24.1	25.2	26.9	23.0	23.5	24.6	26.2	21.9	22.3	23.4	24.9	20.3	20.7	21.6	23.1
		S/T	1.00	0.96	0.87	0.70	1.00	1.00	0.90	0.73	1.00	1.00	0.92	0.75	1.00	1.00	0.95	0.77	1.00	1.00	0.99	0.80	1.00	1.00	0.99	0.81
		ΔT	22	22	21	18	22	22	21	18	21	22	21	18	21	21	21	18	20	20	21	18	18	19	20	17
		kW	1.82	1.85	1.90	1.95	1.94	1.97	2.03	2.09	2.05	2.09	2.15	2.21	2.14	2.18	2.25	2.32	2.22	2.27	2.33	2.40	2.29	2.34	2.41	2.48
		Amps	7.2	7.4	7.6	7.8	7.7	7.9	8.1	8.4	8.3	8.5	8.7	9.0	8.8	9.0	9.2	9.6	9.3	9.5	9.8	10.1	9.8	10.0	10.3	10.7
	Hi PR	145	156	165	172	163	175	185	193	185	199	210	220	211	227	240	250	237	255	270	281	262	282	298	311	
	Lo PR	65	70	76	81	69	74	80	86	72	77	84	89	76	80	88	93	79	84	92	98	82	87	95	101	
	MBh	24.0	24.5	25.7	27.4	23.5	23.9	25.1	26.8	22.9	23.4	24.5	26.1	22.4	22.8	23.9	25.5	21.2	21.7	22.7	24.2	19.7	20.1	21.0	22.4	
	S/T	0.95	0.92	0.83	0.67	0.98	0.95	0.86	0.69	1.00	0.97	0.88	0.71	1.00	1.00	0.91	0.74	1.00	1.00	0.94	0.76	1.00	1.00	0.95	0.77	
	ΔT	23	23	22	19	24	23	22	19	23	23	22	19	23	23	22	19	22	22	22	19	20	20	20	18	
kW	1.80	1.84	1.89	1.94	1.92	1.96	2.02	2.07	2.03	2.07	2.13	2.19	2.12	2.17	2.23	2.30	2.21	2.25	2.32	2.39	2.27	2.32	2.39	2.46		
Amps	7.2	7.3	7.5	7.8	7.7	7.8	8.0	8.3	8.2	8.4	8.7	8.9	8.7	8.9	9.2	9.5	9.2	9.4	9.7	10.0	9.7	9.9	10.2	10.6		
Hi PR	144	155	163	170	161	174	183	191	183	197	208	217	209	225	237	248	235	253	267	279	260	279	295	308		
Lo PR	65	69	75	80	69	73	80	85	71	76	83	88	75	80	87	93	78	83	91	97	81	86	94	100		
MBh	22.2	22.6	23.7	25.3	21.7	22.1	23.1	24.7	21.2	21.6	22.6	24.1	20.6	21.0	22.0	23.5	19.6	20.0	20.9	22.3	18.2	18.5	19.4	20.7		
S/T	0.92	0.88	0.80	0.65	0.95	0.92	0.83	0.67	0.97	0.94	0.85	0.69	1.00	0.97	0.87	0.71	1.00	1.00	0.91	0.74	1.00	1.00	0.91	0.74		
ΔT	24	23	22	19	24	24	22	19	24	24	22	19	24	24	22	19	23	23	22	19	21	22	21	18		
kW	1.77	1.80	1.85	1.90	1.88	1.92	1.97	2.03	1.99	2.02	2.08	2.14	2.08	2.12	2.18	2.25	2.16	2.20	2.26	2.33	2.22	2.27	2.33	2.41		
Amps	7.0	7.1	7.3	7.6	7.5	7.6	7.9	8.1	8.0	8.2	8.4	8.7	8.5	8.7	8.9	9.2	9.0	9.2	9.5	9.8	9.5	9.7	10.0	10.3		
Hi PR	139	150	158	165	156	168	178	185	178	191	202	211	203	218	230	240	228	245	259	270	252	271	286	298		
Lo PR	63	67	73	78	66	71	77	82	69	73	80	85	73	77	84	90	76	81	88	94	79	84	91	97		

Shaded area reflects ARI conditions IDB: Entering Indoor Dry Bulb Temperature kW = Total system power Amps = outdoor unit amps (comp.+fan)
 High and low pressures are measured at the liquid and suction service valves.

EXPANDED COOLING DATA — GPH1330M21A

IDB	Airflow	Outdoor Ambient Temperature																								
		65°F				75°F				85°F				95°F				105°F				115°F				
		59	63	67	71	59	63	67	71	59	63	67	71	59	63	67	71	59	63	67	71	59	63	67	71	
70	1181	MBh	29.4	30.5	33.4	-	28.7	29.8	32.6	-	28.0	29.1	31.8	-	27.3	28.3	31.1	-	26.0	26.9	29.5	-	24.1	24.9	27.3	-
		S/T	0.78	0.65	0.45	-	0.81	0.67	0.47	-	0.83	0.69	0.48	-	0.85	0.71	0.49	-	0.88	0.74	0.51	-	0.89	0.74	0.52	-
		ΔT	18	15	12	-	18	16	12	-	18	16	12	-	18	16	12	-	18	15	12	-	17	14	11	-
		kW	2.14	2.19	2.25	-	2.30	2.35	2.42	-	2.44	2.49	2.57	-	2.57	2.62	2.70	-	2.67	2.73	2.82	-	2.76	2.82	2.91	-
		Amps	7.9	8.1	8.4	-	8.6	8.8	9.1	-	9.3	9.5	9.9	-	10.0	10.2	10.5	-	10.6	10.9	11.2	-	11.2	11.5	11.9	-
	1050	Hi-PR	146	157	166	-	164	176	186	-	186	200	212	-	212	228	241	-	239	257	271	-	264	284	300	-
		Lo-PR	62	66	72	-	66	70	76	-	68	72	79	-	72	76	83	-	75	80	87	-	78	82	90	-
		MBh	28.5	29.6	32.4	-	27.9	28.9	31.7	-	27.2	28.2	30.9	-	26.6	27.5	30.2	-	25.2	26.1	28.6	-	23.4	24.2	26.5	-
		S/T	0.74	0.62	0.43	-	0.77	0.64	0.44	-	0.79	0.66	0.46	-	0.81	0.68	0.47	-	0.84	0.70	0.49	-	0.85	0.71	0.49	-
		ΔT	19	16	12	-	19	16	12	-	19	16	12	-	19	16	12	-	19	16	12	-	17	15	11	-
919	1181	kW	2.13	2.17	2.24	-	2.29	2.33	2.40	-	2.42	2.47	2.55	-	2.55	2.60	2.68	-	2.65	2.71	2.79	-	2.74	2.80	2.89	-
		Amps	7.8	8.0	8.3	-	8.5	8.7	9.0	-	9.2	9.5	9.8	-	9.9	10.1	10.5	-	10.5	10.8	11.1	-	11.1	11.4	11.8	-
		Hi-PR	144	155	164	-	162	174	184	-	184	198	210	-	210	226	239	-	236	254	268	-	261	281	297	-
		Lo-PR	61	65	71	-	65	69	75	-	67	72	78	-	71	75	82	-	74	79	86	-	77	82	89	-
		MBh	26.3	27.3	29.9	-	25.7	26.7	29.2	-	25.1	26.0	28.5	-	24.5	25.4	27.8	-	23.3	24.1	26.4	-	21.6	22.4	24.5	-
	1050	S/T	0.71	0.60	0.41	-	0.74	0.62	0.43	-	0.76	0.63	0.44	-	0.78	0.65	0.45	-	0.81	0.68	0.47	-	0.82	0.68	0.47	-
		ΔT	19	16	12	-	19	16	13	-	19	17	13	-	19	17	13	-	19	16	12	-	18	15	12	-
		kW	2.08	2.12	2.19	-	2.23	2.28	2.35	-	2.37	2.42	2.49	-	2.48	2.54	2.62	-	2.59	2.64	2.72	-	2.67	2.73	2.82	-
		Amps	7.6	7.8	8.1	-	8.3	8.5	8.7	-	9.0	9.2	9.5	-	9.6	9.8	10.2	-	10.2	10.5	10.8	-	10.8	11.1	11.5	-
		Hi-PR	140	151	159	-	157	169	179	-	179	192	203	-	204	219	231	-	229	247	260	-	253	272	288	-
Lo-PR	60	63	69	-	63	67	73	-	65	70	76	-	69	73	80	-	72	77	84	-	74	79	86	-		

75	1181	MBh	29.9	30.8	33.3	35.8	29.2	30.1	32.5	34.9	28.5	29.3	31.8	34.1	27.8	28.6	31.0	33.3	26.4	27.2	29.4	31.6	24.5	25.2	27.3	29.3
		S/T	0.88	0.79	0.60	0.38	0.92	0.82	0.62	0.40	0.94	0.84	0.64	0.41	0.97	0.87	0.66	0.42	1.00	0.90	0.68	0.44	1.00	0.91	0.69	0.44
		ΔT	21	19	15	11	21	19	16	11	21	19	16	11	21	19	16	11	21	19	16	11	19	18	15	10
		kW	2.16	2.21	2.27	2.34	2.32	2.37	2.44	2.52	2.46	2.51	2.59	2.68	2.59	2.64	2.73	2.82	2.69	2.75	2.84	2.93	2.78	2.85	2.94	3.03
		Amps	8.0	8.2	8.5	8.8	8.6	8.9	9.1	9.5	9.4	9.6	10.0	10.3	10.1	10.3	10.6	11.1	10.7	11.0	11.3	11.8	11.4	11.6	12.0	12.5
	1050	Hi-PR	147	159	168	175	165	178	188	196	188	202	214	223	214	231	243	254	241	259	274	286	266	287	303	316
		Lo-PR	63	67	73	77	66	70	77	82	69	73	80	85	72	77	84	89	76	81	88	94	78	83	91	97
		MBh	29.0	29.9	32.3	34.7	28.4	29.2	31.6	33.9	27.7	28.5	30.8	33.1	27.0	27.8	30.1	32.3	25.7	26.4	28.6	30.7	23.8	24.5	26.5	28.4
		S/T	0.84	0.75	0.57	0.37	0.87	0.78	0.59	0.38	0.89	0.80	0.61	0.39	0.92	0.83	0.63	0.40	0.96	0.86	0.65	0.42	0.97	0.86	0.65	0.42
		ΔT	21	20	16	11	22	20	16	11	22	20	16	11	22	20	16	11	22	20	16	11	20	19	15	10
919	kW	2.14	2.19	2.25	2.32	2.30	2.35	2.42	2.50	2.44	2.49	2.57	2.66	2.57	2.62	2.70	2.79	2.67	2.73	2.82	2.91	2.76	2.82	2.91	3.01	
	Amps	7.9	8.1	8.4	8.7	8.6	8.8	9.1	9.4	9.3	9.5	9.9	10.2	10.0	10.2	10.6	11.0	10.6	10.9	11.2	11.7	11.2	11.5	11.9	12.4	
	Hi-PR	146	157	166	173	164	176	186	194	186	200	212	221	212	228	241	251	239	257	271	283	264	284	300	313	
	Lo-PR	62	66	72	77	66	70	76	81	68	72	79	84	72	76	83	88	75	80	87	93	78	83	90	96	
	MBh	26.8	27.6	29.9	32.0	26.2	26.9	29.2	31.3	25.5	26.3	28.5	30.6	24.9	25.7	27.8	29.8	23.7	24.4	26.4	28.3	21.9	22.6	24.4	26.2	

Shaded area reflects ACCA (TVA) conditions IDB: Entering Indoor Dry Bulb Temperature kW = Total system power Amps = outdoor unit amps (comp. +fan)
 High and low pressures are measured at the liquid and suction service valves.

EXPANDED COOLING DATA — GPH1330M21A (CONT.)

IDB	Airflow	Outdoor Ambient Temperature																									
		65°F				75°F				85°F				95°F				105°F				115°F					
		59	63	67	71	59	63	67	71	59	63	67	71	59	63	67	71	59	63	67	71	59	63	67	71		
80	1181	MBh	30.4	31.1	33.2	35.5	29.7	30.4	32.4	34.7	29.0	29.6	31.7	33.9	28.3	28.9	30.9	33.0	26.9	27.5	29.4	31.4	24.9	25.5	27.2	29.1	
		S/T	0.97	0.91	0.74	0.55	1.00	0.94	0.77	0.57	1.00	0.97	0.79	0.59	1.00	1.00	0.81	0.61	1.00	1.00	0.84	0.63	1.00	1.00	0.85	0.63	
	ΔT	23	22	19	15	23	22	19	15	22	23	20	16	22	23	20	16	21	21	19	15	19	20	18	14		
	kW	2.18	2.22	2.29	2.36	2.34	2.39	2.46	2.54	2.48	2.53	2.61	2.70	2.61	2.66	2.75	2.84	2.72	2.77	2.86	2.96	2.81	2.87	2.96	3.06		
	Amps	8.1	8.3	8.5	8.9	8.7	8.9	9.2	9.6	9.5	9.7	10.0	10.4	10.1	10.4	10.7	11.2	10.8	11.1	11.5	11.9	11.5	11.7	12.1	12.6		
	Hi:PR	149	160	169	176	167	180	190	198	190	204	216	225	216	233	246	257	243	262	277	289	269	290	306	319		
	Lo:PR	63	67	73	78	67	71	78	83	69	74	81	86	73	78	85	90	76	81	89	95	79	84	92	98		
	1050	MBh	29.5	30.2	32.3	34.5	28.9	29.5	31.5	33.7	28.2	28.8	30.8	32.9	27.5	28.1	##	32.1	26.1	26.7	28.5	30.5	24.2	24.7	26.4	28.2	
		S/T	0.92	0.87	0.70	0.53	0.96	0.90	0.73	0.55	0.98	0.92	0.75	0.56	1.00	0.95	0.77	0.58	1.00	0.99	0.80	0.60	1.00	0.99	0.81	0.60	
	919	1050	ΔT	24	23	20	16	24	23	20	16	24	23	20	16	24	23	20	16	23	23	20	16	21	22	19	15
kW			2.16	2.21	2.27	2.34	2.32	2.37	2.44	2.52	2.46	2.51	2.59	2.68	2.59	2.64	2.73	2.82	2.69	2.75	2.84	2.93	2.78	2.85	2.94	3.03	
Amps		8.0	8.2	8.5	8.8	8.6	8.9	9.2	9.5	9.4	9.6	10.0	10.3	10.1	10.3	10.7	11.1	10.7	11.0	11.3	11.8	11.4	11.6	12.0	12.5		
Hi:PR		147	159	168	175	165	178	188	196	188	202	214	223	214	231	244	254	241	259	274	286	266	287	303	316		
Lo:PR		63	67	73	77	66	70	77	82	69	73	80	85	72	77	84	89	76	81	88	94	78	83	91	97		
1050		MBh	27.3	27.9	29.8	31.8	26.6	27.2	29.1	31.1	26.0	26.6	28.4	30.3	25.4	25.9	27.7	29.6	24.1	24.6	26.3	28.1	22.3	22.8	24.4	26.0	
		S/T	0.89	0.84	0.68	0.51	0.92	0.87	0.70	0.53	0.95	0.89	0.72	0.54	0.98	0.92	0.75	0.56	1.01	0.95	0.77	0.58	1.02	0.96	0.78	0.58	
85		1181	ΔT	24	23	20	16	25	24	20	16	25	24	21	16	25	24	21	17	24	23	20	16	23	22	19	15
			kW	2.11	2.15	2.22	2.29	2.27	2.31	2.39	2.46	2.40	2.45	2.53	2.61	2.52	2.58	2.66	2.75	2.63	2.68	2.77	2.86	2.72	2.78	2.86	2.96
		Amps	7.8	8.0	8.2	8.5	8.4	8.6	8.9	9.2	9.1	9.4	9.7	10.0	9.8	10.0	10.4	10.7	10.4	10.7	11.0	11.4	11.0	11.3	11.7	12.1	
	Hi:PR	143	154	163	169	160	173	182	190	183	196	207	216	208	224	236	246	234	252	266	277	258	278	294	306		
	Lo:PR	61	65	71	75	64	68	75	79	67	71	78	83	70	75	81	87	73	78	85	91	76	81	88	94		
	1050	MBh	31.0	31.6	33.1	35.3	30.2	30.8	32.3	34.4	29.5	30.1	31.5	33.6	28.8	29.4	30.7	32.8	27.4	27.9	29.2	31.2	25.3	25.8	27.1	28.9	
		S/T	1.00	0.98	0.88	0.72	1.00	1.00	0.92	0.74	1.00	1.00	0.94	0.76	1.00	1.00	0.97	0.79	1.00	1.00	0.96	0.82	1.00	1.00	0.96	0.82	
	919	1050	ΔT	24	24	23	20	24	24	23	20	23	23	23	20	22	23	23	20	21	22	23	20	20	20	21	18
			kW	2.19	2.24	2.31	2.38	2.36	2.41	2.48	2.56	2.50	2.56	2.64	2.72	2.63	2.69	2.77	2.86	2.74	2.80	2.89	2.98	2.83	2.89	2.99	3.09
		Amps	8.1	8.3	8.6	8.9	8.8	9.0	9.3	9.7	9.6	9.8	10.1	10.5	10.2	10.5	10.8	11.3	10.9	11.2	11.6	12.0	11.6	11.9	12.3	12.7	
Hi:PR		150	162	171	178	169	182	192	200	192	207	218	227	219	235	248	259	246	265	279	291	272	292	309	322		
Lo:PR		64	68	74	79	68	72	78	84	70	75	82	87	74	78	86	91	77	82	90	96	80	85	93	99		
1050		MBh	30.1	30.6	32.1	34.2	29.4	29.9	31.3	33.4	28.7	29.2	30.6	32.6	28.0	28.5	29.9	31.8	26.6	27.1	28.4	30.3	24.6	25.1	26.3	28.0	
		S/T	0.97	0.93	0.84	0.68	1.00	0.97	0.87	0.71	1.00	0.99	0.90	0.73	1.00	1.00	0.92	0.75	1.00	1.00	0.96	0.78	1.00	1.00	0.97	0.79	
919		1050	ΔT	25	25	24	21	26	25	24	21	25	25	24	21	24	25	24	21	23	24	24	21	22	22	22	19
			kW	2.18	2.22	2.29	2.36	2.34	2.39	2.46	2.54	2.48	2.53	2.61	2.70	2.61	2.66	2.75	2.84	2.72	2.77	2.86	2.96	2.81	2.87	2.96	3.06
		Amps	8.1	8.3	8.5	8.9	8.7	8.9	9.2	9.6	9.5	9.7	10.0	10.4	10.1	10.4	10.7	11.2	10.8	11.1	11.5	11.9	11.5	11.7	12.1	12.6	
	Hi:PR	149	160	169	176	167	180	190	198	190	204	216	225	216	233	246	257	243	262	277	289	269	290	306	319		
	Lo:PR	63	67	73	78	67	71	78	83	69	74	81	86	73	78	85	90	76	81	89	95	79	84	92	98		
	1050	MBh	27.7	28.3	29.6	31.6	27.1	27.6	28.9	30.9	26.5	27.0	28.2	30.1	25.8	26.3	27.6	29.4	24.5	25.0	26.2	27.9	22.7	23.1	24.2	25.9	
		S/T	0.93	0.90	0.81	0.66	0.97	0.93	0.84	0.68	0.99	0.96	0.86	0.70	1.00	0.99	0.89	0.72	1.00	1.00	0.93	0.75	1.00	1.00	0.93	0.76	
	919	1050	ΔT	26	25	24	21	26	26	24	21	26	26	24	21	26	26	25	21	25	25	24	21	23	23	23	20
			kW	2.13	2.17	2.24	2.31	2.28	2.33	2.40	2.48	2.42	2.47	2.55	2.63	2.55	2.60	2.68	2.77	2.65	2.71	2.79	2.88	2.74	2.80	2.89	2.98
		Amps	7.8	8.0	8.3	8.6	8.5	8.7	9.0	9.3	9.2	9.5	9.8	10.1	9.9	10.1	10.4	10.8	10.5	10.8	11.1	11.6	11.1	11.4	11.8	12.3	
Hi:PR		144	155	164	171	162	174	184	192	184	198	209	218	210	226	239	249	236	254	268	280	261	281	297	309		
Lo:PR		61	65	71	76	65	69	75	80	67	72	78	83	71	75	82	88	74	79	86	92	77	82	89	95		

Shaded area reflects ARI conditions
 High and low pressures are measured at the liquid and suction service valves.
 IDB: Entering Indoor Dry Bulb Temperature
 kW = Total system power
 Amps = outdoor unit amps (comp. -fan)

EXPANDED COOLING DATA — GPH1336M21A

IDB	Airflow	Outdoor Ambient Temperature																							
		65°F				75°F				85°F				95°F				105°F				115°F			
		59	63	67	71	59	63	67	71	59	63	67	71	59	63	67	71	59	63	67	71	59	63	67	71
1350	MBh	34.9	36.2	39.6	-	34.1	35.3	38.7	-	33.3	34.5	37.8	-	32.5	33.6	36.9	-	30.8	32.0	35.0	-	28.6	29.6	32.4	-
	S/T	0.75	0.63	0.44	-	0.78	0.65	0.45	-	0.80	0.67	0.46	-	0.83	0.69	0.48	-	0.86	0.72	0.50	-	0.86	0.72	0.50	-
	ΔT	18	15	12	-	18	16	12	-	18	16	12	-	18	16	12	-	18	16	12	-	17	15	11	-
	kW	2.49	2.54	2.61	-	2.67	2.72	2.80	-	2.83	2.88	2.97	-	2.97	3.03	3.12	-	3.09	3.15	3.25	-	3.19	3.26	3.36	-
	Amps	10.8	11.0	11.3	-	11.6	11.8	12.1	-	12.4	12.7	13.1	-	13.2	13.5	13.9	-	13.9	14.3	14.7	-	14.7	15.0	15.5	-
	Hi PR	147	158	167	-	165	177	187	-	187	202	213	-	213	230	243	-	240	258	273	-	265	285	301	-
	Lo PR	64	68	74	-	67	71	78	-	70	74	81	-	73	78	85	-	77	82	89	-	79	85	92	-
	MBh	33.9	35.1	38.5	-	33.1	34.3	37.6	-	32.3	33.5	36.7	-	31.5	32.7	35.8	-	29.9	31.0	34.0	-	27.7	28.7	31.5	-
	S/T	0.72	0.60	0.42	-	0.74	0.62	0.43	-	0.76	0.64	0.44	-	0.79	0.66	0.46	-	0.82	0.68	0.47	-	0.82	0.69	0.48	-
	ΔT	19	16	12	-	19	16	12	-	19	16	12	-	19	16	12	-	19	16	12	-	18	15	12	-
70	kW	2.47	2.52	2.59	-	2.65	2.70	2.78	-	2.80	2.86	2.95	-	2.94	3.01	3.10	-	3.06	3.13	3.23	-	3.16	3.23	3.33	-
	Amps	10.7	10.9	11.3	-	11.5	11.7	12.1	-	12.3	12.6	13.0	-	13.1	13.4	13.8	-	13.8	14.1	14.6	-	14.6	14.9	15.3	-
	Hi PR	145	156	165	-	163	176	185	-	186	200	211	-	211	227	240	-	238	256	270	-	263	283	298	-
	Lo PR	63	67	73	-	66	71	77	-	69	73	80	-	73	77	84	-	76	81	88	-	79	84	91	-
	MBh	31.3	32.4	35.5	-	30.5	31.6	34.7	-	29.8	30.9	33.8	-	29.1	30.1	33.0	-	27.6	28.6	31.4	-	25.6	26.5	29.1	-
	S/T	0.69	0.58	0.40	-	0.72	0.60	0.42	-	0.74	0.61	0.43	-	0.76	0.63	0.44	-	0.79	0.66	0.46	-	0.80	0.66	0.46	-
	ΔT	19	16	12	-	19	17	13	-	19	17	13	-	19	17	13	-	19	17	13	-	18	15	12	-
	kW	2.41	2.46	2.53	-	2.59	2.64	2.72	-	2.74	2.79	2.88	-	2.87	2.93	3.03	-	2.99	3.05	3.15	-	3.09	3.15	3.25	-
	Amps	10.5	10.7	11.0	-	11.2	11.4	11.8	-	12.0	12.3	12.7	-	12.8	13.0	13.4	-	13.5	13.8	14.2	-	14.2	14.5	15.0	-
	Hi PR	141	152	160	-	158	170	180	-	180	194	204	-	205	221	233	-	231	248	262	-	255	274	289	-
Lo PR	61	65	71	-	64	69	75	-	67	71	78	-	70	75	82	-	74	78	86	-	76	81	89	-	

1350	MBh	35.5	36.5	39.5	42.4	34.7	35.7	38.6	41.4	33.8	34.8	37.7	40.5	33.0	34.0	36.8	39.5	31.4	32.3	34.9	37.5	29.0	29.9	32.4	34.7
	S/T	0.86	0.77	0.58	0.37	0.89	0.79	0.60	0.39	0.91	0.81	0.62	0.40	0.94	0.84	0.64	0.41	0.97	0.87	0.66	0.42	0.98	0.88	0.67	0.43
	ΔT	21	19	16	11	21	19	16	11	21	19	16	11	21	19	16	11	21	19	16	11	21	19	16	11
	kW	2.50	2.55	2.63	2.71	2.69	2.74	2.83	2.91	2.85	2.91	3.00	3.09	2.99	3.05	3.15	3.25	3.11	3.18	3.28	3.39	3.22	3.28	3.39	3.50
	Amps	10.9	11.1	11.4	11.8	11.7	11.9	12.2	12.7	12.5	12.8	13.2	13.6	13.3	13.6	14.0	14.5	14.1	14.4	14.8	15.3	14.8	15.1	15.6	16.2
	Hi PR	148	160	169	176	166	179	189	197	189	204	215	224	216	232	245	256	243	261	276	287	268	288	305	318
	Lo PR	64	68	75	79	68	72	79	84	70	75	82	87	74	79	86	92	78	83	90	96	80	85	93	99
	MBh	34.4	35.5	38.4	41.2	33.6	34.6	37.5	40.2	32.8	33.8	36.6	39.3	32.0	33.0	35.7	38.3	30.4	31.3	33.9	36.4	28.2	29.0	31.4	33.7
	S/T	0.82	0.73	0.55	0.36	0.85	0.76	0.57	0.37	0.87	0.78	0.59	0.38	0.90	0.80	0.61	0.39	0.93	0.83	0.63	0.40	0.94	0.84	0.63	0.41
	ΔT	22	20	16	11	22	20	16	11	22	20	16	11	22	20	17	11	22	20	16	11	20	19	15	11
1200	kW	2.49	2.54	2.61	2.69	2.67	2.72	2.80	2.89	2.83	2.88	2.97	3.07	2.97	3.03	3.12	3.22	3.09	3.15	3.25	3.36	3.19	3.26	3.36	3.47
	Amps	10.8	11.0	11.3	11.7	11.6	11.8	12.1	12.5	12.4	12.7	13.1	13.5	13.2	13.5	13.9	14.4	14.0	14.3	14.7	15.2	14.7	15.0	15.5	16.0
	Hi PR	147	158	167	174	165	177	187	195	187	202	213	222	213	230	243	253	240	258	273	285	265	286	301	314
	Lo PR	64	68	74	79	67	71	78	83	70	74	81	86	73	78	85	91	77	82	89	95	79	85	92	98
	MBh	31.8	32.7	35.4	38.0	31.1	32.0	34.6	37.1	30.3	31.2	33.8	36.3	29.6	30.4	33.0	35.4	28.1	28.9	31.3	33.6	26.0	26.8	29.0	31.1
	S/T	0.79	0.70	0.53	0.34	0.82	0.73	0.55	0.36	0.84	0.75	0.57	0.36	0.86	0.77	0.58	0.38	0.90	0.80	0.61	0.39	0.90	0.81	0.61	0.39
	ΔT	22	20	17	11	22	20	17	12	22	20	17	12	22	21	17	12	22	20	17	12	21	19	16	11
	kW	2.43	2.48	2.55	2.63	2.61	2.66	2.74	2.82	2.76	2.82	2.90	3.00	2.90	2.96	3.05	3.15	3.01	3.08	3.17	3.28	3.11	3.18	3.28	3.39
	Amps	10.6	10.8	11.1	11.4	11.3	11.5	11.9	12.2	12.1	12.4	12.8	13.2	12.9	13.1	13.5	14.0	13.6	13.9	14.3	14.8	14.3	14.6	15.1	15.6
	Hi PR	142	153	162	169	160	172	182	189	182	196	207	215	207	223	235	245	233	251	265	276	257	277	292	305
Lo PR	62	66	72	76	65	69	76	81	68	72	79	84	71	76	83	88	75	79	87	92	77	82	90	95	

Shaded area reflects ACOA (TVA) conditions IDB: Entering Indoor Dry Bulb Temperature kW = Total system power Amps = outdoor unit amps (comp.+fan)
 High and low pressures are measured at the liquid and suction service valves.

EXPANDED COOLING DATA — GPH1336M21A (CONT.)

IDB	Airflow	Outdoor Ambient Temperature																								
		65°F				75°F				85°F				95°F				105°F				115°F				
		59	63	67	71	59	63	67	71	59	63	67	71	59	63	67	71	59	63	67	71	59	63	67	71	
80	1350	MBh	36.1	36.9	39.4	42.1	35.3	36.0	38.5	41.2	34.4	35.2	37.6	40.2	33.6	34.3	36.7	39.2	31.9	32.6	34.8	37.2	29.6	30.2	32.3	34.5
		S/T	0.94	0.88	0.72	0.54	1.00	0.91	0.74	0.56	1.00	0.94	0.76	0.57	1.00	0.97	0.79	0.59	1.00	1.00	0.82	0.61	1.00	1.00	0.82	0.62
	ΔT	23	22	19	15	24	22	19	16	23	22	20	16	23	23	20	16	22	22	19	15	20	21	18	14	
	kW	2.52	2.57	2.65	2.73	2.71	2.76	2.85	2.94	2.87	2.93	3.02	3.12	3.01	3.08	3.18	3.28	3.14	3.20	3.31	3.41	3.24	3.31	3.42	3.53	
	Amps	11.0	11.2	11.5	11.9	11.8	12.0	12.3	12.8	12.6	12.9	13.3	13.7	13.4	13.7	14.1	14.6	14.2	14.5	14.9	15.5	14.9	15.3	15.7	16.3	
	Hi PR	150	161	170	178	168	181	191	199	191	206	217	227	218	234	247	258	245	264	278	290	271	291	308	321	
	Lo PR	65	69	75	80	69	73	80	85	71	76	83	88	75	80	87	93	78	83	91	97	81	86	94	100	
	MBh	35.1	35.8	38.3	40.9	34.2	35.0	37.4	40.0	33.4	34.2	36.5	39.0	32.6	33.3	35.6	38.1	31.0	31.7	33.8	36.2	28.7	29.3	31.3	33.5	
	S/T	0.90	0.84	0.68	0.51	0.93	0.87	0.71	0.53	0.95	0.89	0.73	0.54	0.98	0.92	0.75	0.56	1.00	0.96	0.78	0.58	1.00	0.96	0.78	0.59	
	ΔT	24	23	20	16	24	23	20	16	24	23	20	16	25	24	20	16	24	23	20	16	22	22	19	15	
kW	2.50	2.55	2.63	2.71	2.69	2.74	2.83	2.91	2.85	2.91	3.00	3.09	2.99	3.05	3.15	3.25	3.11	3.18	3.28	3.39	3.22	3.29	3.39	3.50		
Amps	10.9	11.1	11.4	11.8	11.7	11.9	12.2	12.7	12.5	12.8	13.2	13.6	13.3	13.6	14.0	14.5	14.1	14.4	14.8	15.3	14.8	15.1	15.6	16.2		
Hi PR	148	160	169	176	166	179	189	197	189	204	215	224	216	232	245	256	243	261	276	287	268	288	305	318		
Lo PR	64	68	75	79	68	72	79	84	70	75	82	87	74	79	86	92	78	83	90	96	80	85	93	99		
MBh	32.4	33.1	35.3	37.8	31.6	32.3	34.5	36.9	30.9	31.5	33.7	36.0	30.1	30.8	32.9	35.1	28.6	29.2	31.2	33.4	26.5	27.1	28.9	30.9		
S/T	0.86	0.81	0.66	0.49	0.90	0.84	0.68	0.51	0.92	0.86	0.70	0.52	0.95	0.89	0.72	0.54	0.98	0.92	0.75	0.56	0.99	0.93	0.76	0.57		
ΔT	24	23	20	16	25	24	21	16	25	24	21	17	25	24	21	17	25	24	21	16	23	22	19	15		
kW	2.45	2.50	2.57	2.65	2.63	2.68	2.76	2.85	2.78	2.84	2.93	3.02	2.92	2.98	3.07	3.17	3.04	3.10	3.20	3.30	3.14	3.21	3.31	3.41		
Amps	10.6	10.9	11.2	11.5	11.4	11.6	12.0	12.3	12.2	12.5	12.9	13.3	13.0	13.3	13.7	14.1	13.7	14.0	14.4	14.9	14.4	14.8	15.2	15.7		
Hi PR	144	155	164	171	161	174	183	191	184	198	209	218	209	225	238	248	235	253	267	279	260	280	295	308		
Lo PR	62	66	72	77	66	70	76	81	68	73	79	85	72	76	83	89	75	80	87	93	78	83	90	96		

85	1350	MBh	36.7	37.4	39.2	41.8	35.9	36.6	38.3	40.9	35.0	35.7	37.4	39.9	34.2	34.8	36.5	38.9	32.5	33.1	34.7	37.0	30.1	30.7	32.1	34.3
		S/T	0.98	0.95	0.86	0.70	1.00	0.98	0.89	0.72	1.00	1.00	0.91	0.74	1.00	1.00	0.94	0.76	1.00	1.00	0.98	0.79	1.00	1.00	0.98	0.80
	ΔT	25	24	23	20	24	25	23	20	24	24	23	20	23	24	23	20	22	23	23	20	20	21	22	19	
	kW	2.54	2.59	2.67	2.75	2.73	2.78	2.87	2.96	2.89	2.95	3.05	3.14	3.04	3.10	3.20	3.30	3.16	3.23	3.33	3.44	3.27	3.34	3.45	3.56	
	Amps	11.1	11.3	11.6	12.0	11.8	12.1	12.4	12.9	12.7	13.0	13.4	13.9	13.5	13.8	14.2	14.7	14.3	14.6	15.1	15.6	15.1	15.4	15.9	16.4	
	Hi PR	151	163	172	179	170	183	193	201	193	208	219	229	220	237	250	261	247	266	281	293	273	294	311	324	
	Lo PR	65	70	76	81	69	74	80	86	72	77	84	89	76	80	88	93	79	84	92	98	82	87	95	101	
	MBh	35.7	36.4	38.1	40.6	34.8	35.5	37.2	39.7	34.0	34.7	36.3	38.7	33.2	33.8	35.4	37.8	31.5	32.1	33.7	35.9	29.2	29.8	31.2	33.3	
	S/T	0.94	0.91	0.82	0.66	0.97	0.94	0.85	0.69	1.00	0.96	0.87	0.71	1.00	0.99	0.90	0.73	1.00	1.00	0.93	0.76	1.00	1.00	0.94	0.76	
	ΔT	26	25	24	21	26	26	24	21	26	26	24	21	25	26	24	21	24	25	24	21	22	23	22	19	
kW	2.52	2.57	2.65	2.73	2.71	2.76	2.85	2.94	2.87	2.93	3.02	3.12	3.01	3.08	3.18	3.28	3.14	3.20	3.31	3.41	3.24	3.31	3.42	3.53		
Amps	11.0	11.2	11.5	11.9	11.8	12.0	12.3	12.8	12.6	12.9	13.3	13.7	13.4	13.7	14.1	14.6	14.2	14.5	14.9	15.5	14.9	15.3	15.7	16.3		
Hi PR	150	161	170	178	168	181	191	199	191	206	217	227	218	234	247	258	245	264	278	290	271	291	308	321		
Lo PR	65	69	75	80	69	73	80	85	71	76	83	88	75	80	87	93	78	83	91	97	81	86	94	100		
MBh	32.9	33.6	35.1	37.5	32.2	32.8	34.3	36.6	31.4	32.0	33.5	35.8	30.6	31.2	32.7	34.9	29.1	29.7	31.1	33.1	26.9	27.5	28.8	30.7		
S/T	0.91	0.87	0.79	0.64	0.94	0.91	0.82	0.66	0.96	0.93	0.84	0.68	0.99	0.96	0.86	0.70	1.00	0.99	0.90	0.73	1.00	1.00	0.91	0.73		
ΔT	26	26	24	21	26	26	25	21	26	26	25	21	27	26	25	21	25	26	24	21	24	24	23	20		
kW	2.47	2.52	2.59	2.67	2.65	2.70	2.78	2.87	2.80	2.86	2.95	3.04	2.94	3.00	3.10	3.20	3.06	3.13	3.23	3.33	3.16	3.23	3.33	3.44		
Amps	10.7	10.9	11.3	11.6	11.5	11.7	12.0	12.4	12.3	12.6	13.0	13.4	13.1	13.4	13.8	14.2	13.8	14.1	14.6	15.1	14.6	14.9	15.3	15.9		
Hi PR	145	156	165	172	163	175	185	193	185	200	211	220	211	227	240	250	238	256	270	282	263	283	298	311		
Lo PR	63	67	73	78	66	71	77	82	69	73	80	85	73	77	84	90	76	81	88	94	79	84	91	97		

Shaded area reflects ARI conditions IDB: Entering Indoor Dry Bulb Temperature kW = Total system power Amps = outdoor unit amps (comp.+fan)
 High and low pressures are measured at the liquid and suction service valves.

EXPANDED COOLING DATA — GPH1348M21A

IDB	Airflow	Outdoor Ambient Temperature																							
		65°F				75°F				85°F				95°F				105°F				115°F			
		59	63	67	71	59	63	67	71	59	63	67	71	59	63	67	71	59	63	67	71	59	63	67	71
1969	MBh	47.0	48.8	53.4	-	45.9	47.6	52.2	-	44.8	46.5	50.9	-	43.8	45.4	49.7	-	41.6	43.1	47.2	-	38.5	39.9	43.7	-
	S/T	0.76	0.64	0.44	-	0.79	0.66	0.46	-	0.81	0.68	0.47	-	0.84	0.70	0.48	-	0.87	0.73	0.50	-	0.88	0.73	0.51	-
	ΔT	17	15	11	-	17	15	11	-	17	15	11	-	17	15	11	-	17	15	11	-	16	14	10	-
	kW	3.30	3.36	3.46	-	3.53	3.61	3.72	-	3.74	3.82	3.94	-	3.93	4.01	4.14	-	4.09	4.17	4.30	-	4.22	4.31	4.45	-
	Amps	16.3	16.6	17.0	-	17.3	17.6	18.0	-	18.4	18.8	19.3	-	19.4	19.8	20.3	-	20.4	20.8	21.4	-	21.4	21.9	22.5	-
	Hi PR	150	161	170	-	168	181	191	-	191	206	217	-	218	234	247	-	245	264	278	-	271	291	308	-
	Lo PR	64	68	75	-	68	72	79	-	71	75	82	-	74	79	86	-	78	83	90	-	80	86	93	-
	MBh	45.7	47.3	51.9	-	44.6	46.2	50.7	-	43.5	45.1	49.4	-	42.5	44.0	48.2	-	40.4	41.8	45.8	-	37.4	38.7	42.5	-
	S/T	0.73	0.61	0.42	-	0.75	0.63	0.44	-	0.77	0.65	0.45	-	0.80	0.67	0.46	-	0.83	0.69	0.48	-	0.84	0.70	0.48	-
	ΔT	17	15	11	-	18	15	12	-	18	15	12	-	18	15	12	-	18	15	12	-	16	14	11	-
70	kW	3.27	3.34	3.44	-	3.51	3.58	3.69	-	3.72	3.79	3.91	-	3.90	3.98	4.10	-	4.05	4.14	4.27	-	4.19	4.28	4.41	-
	Amps	16.2	16.4	16.9	-	17.1	17.5	17.9	-	18.3	18.6	19.1	-	19.3	19.7	20.2	-	20.3	20.7	21.2	-	21.3	21.7	22.3	-
	Hi PR	148	160	169	-	166	179	189	-	189	204	215	-	216	232	245	-	243	261	276	-	268	288	305	-
	Lo PR	64	68	74	-	67	72	78	-	70	74	81	-	73	78	85	-	77	82	89	-	80	85	92	-
	MBh	42.1	43.7	47.9	-	41.2	42.7	46.8	-	40.2	41.7	45.6	-	39.2	40.6	44.5	-	37.2	38.6	42.3	-	34.5	35.8	39.2	-
	S/T	0.70	0.59	0.41	-	0.73	0.61	0.42	-	0.75	0.62	0.43	-	0.77	0.64	0.45	-	0.80	0.67	0.46	-	0.81	0.67	0.47	-
	ΔT	18	15	12	-	18	16	12	-	18	16	12	-	18	16	12	-	18	15	12	-	17	14	11	-
	kW	3.20	3.26	3.36	-	3.43	3.50	3.60	-	3.63	3.70	3.82	-	3.81	3.89	4.01	-	3.96	4.04	4.17	-	4.09	4.17	4.31	-
	Amps	15.8	16.1	16.5	-	16.8	17.1	17.5	-	17.9	18.2	18.7	-	18.9	19.2	19.7	-	19.8	20.2	20.8	-	20.8	21.2	21.8	-
	Hi PR	144	155	164	-	161	174	183	-	184	198	209	-	209	225	238	-	235	253	267	-	260	280	295	-
Lo PR	62	66	72	-	65	69	76	-	68	72	79	-	71	76	83	-	75	79	87	-	77	82	90	-	

1969	MBh	47.8	49.2	53.3	57.2	46.7	48.1	52.1	55.9	45.6	47.0	50.8	54.6	44.5	45.8	49.6	53.2	42.3	43.5	47.1	50.6	39.2	40.3	43.6	46.8
	S/T	0.87	0.78	0.59	0.38	0.90	0.80	0.61	0.39	0.92	0.82	0.62	0.40	0.95	0.85	0.64	0.41	0.99	0.88	0.67	0.43	1.00	0.89	0.67	0.43
	ΔT	19	18	15	10	20	18	15	10	20	18	15	10	20	18	15	10	20	18	15	10	18	17	14	9
	kW	3.32	3.39	3.49	3.59	3.56	3.63	3.74	3.86	3.77	3.85	3.97	4.10	3.96	4.04	4.17	4.30	4.12	4.21	4.34	4.48	4.26	4.35	4.49	4.63
	Amps	16.4	16.7	17.1	17.6	17.4	17.7	18.2	18.7	18.6	18.9	19.4	20.0	19.6	20.0	20.5	21.1	20.6	21.0	21.6	22.3	21.6	22.0	22.6	23.4
	Hi PR	151	163	172	179	170	183	193	201	193	208	219	229	220	237	250	261	247	266	281	293	273	294	311	324
	Lo PR	65	69	75	80	69	73	80	85	71	76	83	88	75	80	87	93	78	84	91	97	81	86	94	100
	MBh	46.4	47.8	51.8	55.5	45.4	46.7	50.6	54.3	44.3	45.6	49.3	53.0	43.2	44.5	48.1	51.7	41.0	42.3	45.7	49.1	38.0	39.1	42.4	45.5
	S/T	0.83	0.74	0.56	0.36	0.86	0.77	0.58	0.37	0.88	0.79	0.60	0.38	0.91	0.81	0.61	0.40	0.94	0.84	0.64	0.41	0.95	0.85	0.64	0.41
	ΔT	20	19	15	11	20	19	15	11	20	19	15	11	21	19	16	11	20	19	15	11	19	17	14	10
75	kW	3.30	3.36	3.46	3.57	3.54	3.61	3.72	3.83	3.74	3.82	3.94	4.06	3.93	4.01	4.14	4.27	4.09	4.17	4.30	4.44	4.22	4.31	4.45	4.59
	Amps	16.3	16.6	17.0	17.5	17.3	17.6	18.0	18.6	18.4	18.8	19.3	19.9	19.4	19.8	20.3	21.0	20.4	20.8	21.4	22.1	21.4	21.9	22.5	23.2
	Hi PR	150	161	170	178	168	181	191	199	191	206	217	227	218	234	248	258	245	264	278	290	271	291	308	321
	Lo PR	64	68	75	80	68	72	79	84	71	75	82	87	74	79	86	92	78	83	90	96	80	86	93	99
	MBh	42.9	44.1	47.8	51.3	41.9	43.1	46.7	50.1	40.9	42.1	45.5	48.9	39.9	41.1	44.4	47.7	37.9	39.0	42.2	45.3	35.1	36.1	39.1	42.0
	S/T	0.80	0.71	0.54	0.35	0.83	0.74	0.56	0.36	0.85	0.76	0.57	0.37	0.88	0.78	0.59	0.38	0.91	0.81	0.62	0.40	0.92	0.82	0.62	0.40
	ΔT	21	19	15	11	21	19	16	11	21	19	16	11	21	19	16	11	21	19	16	11	19	18	15	10
	kW	3.22	3.29	3.38	3.49	3.45	3.52	3.63	3.74	3.66	3.73	3.85	3.97	3.84	3.92	4.04	4.17	3.99	4.07	4.20	4.33	4.12	4.21	4.34	4.48
	Amps	15.9	16.2	16.6	17.1	16.9	17.2	17.7	18.2	18.0	18.4	18.9	19.4	19.0	19.4	19.9	20.5	20.0	20.4	20.9	21.6	20.9	21.4	21.9	22.6
	Hi PR	145	156	165	172	163	176	185	193	185	200	211	220	212	227	240	250	238	256	270	282	263	283	298	311
Lo PR	62	66	72	77	66	70	77	82	68	73	80	85	72	77	84	89	75	80	88	93	78	83	91	96	

Shaded area reflects ACOA (TVA) conditions IDB: Entering Indoor Dry Bulb Temperature kW = Total system power Amps = outdoor unit amps (comp.+fan)
 High and low pressures are measured at the liquid and suction service valves.

EXPANDED COOLING DATA — GPH1348M21A (CONT.)

IDB		Outdoor Ambient Temperature																											
		65°F				75°F				85°F				95°F				105°F				115°F							
		59	63	67	71	59	63	67	71	59	63	67	71	59	63	67	71	59	63	67	71	59	63	67	71				
		Entering Indoor Wet Bulb Temperature																											
80	Airflow	59	63	67	71	59	63	67	71	59	63	67	71	59	63	67	71	59	63	67	71	59	63	67	71	59	63	67	71
	MBh	48.7	49.7	53.1	56.8	47.6	48.6	51.9	55.5	46.4	47.4	50.7	54.2	45.3	46.3	49.4	52.9	43.0	44.0	47.0	50.2	39.9	40.7	43.5	46.5				
	S/T	0.95	0.89	0.73	0.54	1.00	0.93	0.75	0.56	1.00	0.95	0.77	0.58	1.00	1.00	0.80	0.60	1.00	1.00	0.83	0.62	1.00	1.00	0.83	0.62				
	ΔT	22	21	18	14	22	21	18	15	21	22	18	15	21	22	18	15	21	22	18	14	19	19	17	14				
	kW	3.35	3.41	3.52	3.62	3.59	3.66	3.77	3.89	3.80	3.88	4.00	4.13	3.99	4.08	4.20	4.34	4.15	4.24	4.37	4.52	4.29	4.38	4.52	4.67				
	Amps	16.5	16.8	17.2	17.7	17.5	17.8	18.3	18.8	18.7	19.1	19.6	20.2	19.7	20.1	20.7	21.3	20.7	21.2	21.7	22.4	21.8	22.2	22.8	23.5				
	Hi PR	153	165	174	181	172	185	195	203	195	210	222	231	222	239	253	263	250	269	284	296	276	297	314	327				
	Lo PR	66	70	76	81	69	74	80	86	72	77	84	89	76	80	88	94	79	84	92	98	82	87	95	101				
	MBh	47.3	48.3	51.6	55.2	46.2	47.2	50.4	53.9	45.1	46.1	49.2	52.6	44.0	44.9	##	##	51.3	41.8	42.7	45.6	48.7	38.7	39.5	42.2				
	S/T	0.91	0.85	0.69	0.52	0.94	0.88	0.72	0.54	0.96	0.90	0.74	0.55	1.00	0.93	0.76	0.57	1.00	0.97	0.79	0.59	1.00	0.98	0.80	0.59				
ΔT	23	22	19	15	23	22	19	15	23	22	19	15	23	22	19	15	22	22	19	15	20	20	18	14					
kW	3.32	3.39	3.49	3.59	3.56	3.64	3.75	3.86	3.77	3.85	3.97	4.10	3.96	4.04	4.17	4.30	4.12	4.21	4.34	4.48	4.26	4.35	4.49	4.63					
Amps	16.4	16.7	17.1	17.6	17.4	17.7	18.2	18.7	18.6	18.9	19.4	20.0	19.6	20.0	20.5	21.1	20.6	21.0	21.6	22.3	21.6	22.0	22.6	23.4					
Hi PR	151	163	172	179	170	183	193	201	193	208	220	229	220	237	250	261	248	266	281	293	273	294	311	324					
Lo PR	65	69	75	80	69	73	80	85	71	76	83	88	75	80	87	93	79	84	91	97	81	86	94	100					
MBh	43.6	44.6	47.6	50.9	42.6	43.5	46.5	49.7	41.6	42.5	45.4	48.5	40.6	41.5	44.3	47.4	38.6	39.4	42.1	45.0	35.7	36.5	39.0	41.7					
S/T	0.88	0.82	0.67	0.50	0.91	0.85	0.69	0.52	0.93	0.87	0.71	0.53	0.96	0.90	0.73	0.55	1.00	0.93	0.76	0.57	1.00	0.94	0.77	0.57					
ΔT	23	22	19	15	23	22	19	15	23	22	19	15	23	22	19	16	23	22	19	15	22	21	18	14					
kW	3.25	3.31	3.41	3.51	3.48	3.55	3.66	3.77	3.69	3.76	3.88	4.00	3.87	3.95	4.07	4.20	4.02	4.11	4.23	4.37	4.15	4.24	4.38	4.52					
Amps	16.0	16.3	16.7	17.2	17.0	17.3	17.8	18.3	18.2	18.5	19.0	19.6	19.1	19.5	20.0	20.7	20.1	20.5	21.1	21.7	21.1	21.5	22.1	22.8					
Hi PR	147	158	167	174	165	177	187	195	187	202	213	222	213	230	243	253	240	258	273	285	265	285	301	314					
Lo PR	63	67	73	78	67	71	77	82	69	74	80	86	73	77	84	90	76	81	88	94	79	84	91	97					

85	MBh	49.5	50.5	52.9	56.4	48.4	49.3	51.7	55.1	47.2	48.1	50.4	53.8	46.1	47.0	49.2	52.5	43.8	44.6	46.7	49.9	40.5	41.3	43.3	46.2
	S/T	1.00	0.96	0.87	0.70	1.00	1.00	0.90	0.73	1.00	1.00	0.92	0.75	1.00	1.00	0.95	0.77	1.00	1.00	0.99	0.80	1.00	1.00	1.00	0.81
	ΔT	23	23	21	19	23	23	22	19	22	22	22	19	22	22	22	19	20	21	22	19	19	19	20	17
	kW	3.37	3.44	3.54	3.65	3.62	3.69	3.80	3.92	3.83	3.91	4.03	4.16	4.02	4.11	4.24	4.37	4.19	4.27	4.41	4.55	4.32	4.42	4.56	4.71
	Amps	16.6	16.9	17.3	17.8	17.6	18.0	18.4	19.0	18.8	19.2	19.7	20.3	19.9	20.3	20.8	21.5	20.9	21.3	21.9	22.6	21.9	22.4	23.0	23.7
	Hi PR	154	166	175	183	173	186	197	205	197	212	224	234	224	242	255	266	252	272	287	299	279	300	317	331
	Lo PR	66	70	77	82	70	74	81	87	73	77	84	90	76	81	89	95	80	85	93	99	83	88	96	102
	MBh	48.1	49.0	51.3	54.8	47.0	47.9	50.1	53.5	45.9	46.7	49.0	52.2	44.7	45.6	47.8	51.0	42.5	43.3	45.4	48.4	39.4	40.1	42.0	44.8
	S/T	0.95	0.92	0.83	0.67	0.99	0.95	0.86	0.70	1.00	0.98	0.88	0.71	1.00	1.00	0.91	0.74	1.00	1.00	0.94	0.77	1.00	1.00	0.95	0.77
	ΔT	24	24	22	19	24	24	23	20	24	24	23	20	24	24	23	20	22	23	22	19	21	21	21	18
kW	3.35	3.41	3.52	3.62	3.59	3.66	3.77	3.89	3.80	3.88	4.00	4.13	3.99	4.08	4.20	4.34	4.15	4.24	4.37	4.52	4.29	4.38	4.52	4.67	
Amps	16.5	16.8	17.2	17.7	17.5	17.8	18.3	18.8	18.7	19.1	19.6	20.2	19.7	20.1	20.7	21.3	20.7	21.2	21.7	22.4	21.8	22.2	22.8	23.5	
Hi PR	153	165	174	181	172	185	195	203	195	210	222	231	222	239	253	263	250	269	284	296	276	297	314	327	
Lo PR	66	70	76	81	69	74	80	86	72	77	84	89	76	80	88	94	79	84	92	98	82	87	95	101	
MBh	44.4	45.2	47.4	50.6	43.4	44.2	46.3	49.4	42.3	43.1	45.2	48.2	41.3	42.1	44.1	47.0	39.2	40.0	41.9	44.7	36.3	37.0	38.8	41.4	
S/T	0.92	0.89	0.80	0.65	0.95	0.92	0.83	0.67	0.98	0.94	0.85	0.69	1.00	0.97	0.88	0.71	1.00	1.00	0.91	0.74	1.00	1.00	0.92	0.74	
ΔT	24	24	23	20	25	24	23	20	25	24	23	20	25	25	23	20	24	24	23	20	22	22	21	18	
kW	3.27	3.34	3.44	3.54	3.51	3.58	3.69	3.80	3.71	3.79	3.91	4.03	3.90	3.98	4.10	4.23	4.05	4.14	4.27	4.41	4.19	4.28	4.41	4.55	
Amps	16.1	16.4	16.9	17.3	17.1	17.5	17.9	18.4	18.3	18.6	19.1	19.7	19.3	19.7	20.2	20.8	20.3	20.7	21.2	21.9	21.3	21.7	22.3	23.0	
Hi PR	148	160	169	176	166	179	189	197	189	204	215	224	216	232	245	255	242	261	276	287	268	288	304	318	
Lo PR	64	68	74	79	67	72	78	83	70	74	81	86	73	78	85	91	77	82	89	95	80	85	92	98	

Shaded area reflects ARI conditions IDB: Entering Indoor Dry Bulb Temperature kW = Total system power Amps = outdoor unit amps (comp. +fan)
 High and low pressures are measured at the liquid and suction service valves.

EXPANDED COOLING DATA — GPH1360M21A

IDB	Airflow	Outdoor Ambient Temperature																							
		65°F				75°F				85°F				95°F				105°F				115°F			
		59	63	67	71	59	63	67	71	59	63	67	71	59	63	67	71	59	63	67	71	59	63	67	71
70	MBh	55.9	57.9	63.4	-	54.6	56.5	62.0	-	53.3	55.2	60.5	-	52.0	53.9	59.0	-	49.4	51.2	56.1	-	45.7	47.4	51.9	-
	S/T	0.75	0.63	0.44	-	0.78	0.65	0.45	-	0.80	0.67	0.46	-	0.83	0.69	0.48	-	0.86	0.72	0.50	-	0.86	0.72	0.50	-
	ΔT	19	16	12	-	19	16	12	-	19	16	12	-	19	16	12	-	19	16	12	-	17	15	11	-
	kW	4.31	4.40	4.53	-	4.63	4.72	4.87	-	4.91	5.01	5.17	-	5.16	5.27	5.43	-	5.37	5.48	5.66	-	5.55	5.67	5.85	-
	Amps	18.3	18.7	19.2	-	19.6	20.0	20.6	-	21.1	21.5	22.2	-	22.3	22.8	23.5	-	23.6	24.1	24.9	-	24.9	25.4	26.2	-
	Hi PR	156	168	177	-	175	188	199	-	199	214	226	-	226	244	257	-	255	274	290	-	281	303	320	-
	Lo PR	62	66	72	-	66	70	76	-	68	73	79	-	72	76	83	-	75	80	87	-	78	83	90	-
	MBh	54.2	56.2	61.6	-	53.0	54.9	60.1	-	51.7	53.6	58.7	-	50.4	52.3	57.3	-	47.9	49.7	54.4	-	44.4	46.0	50.4	-
	S/T	0.72	0.60	0.42	-	0.74	0.62	0.43	-	0.76	0.64	0.44	-	0.79	0.66	0.46	-	0.82	0.68	0.47	-	0.82	0.69	0.48	-
	ΔT	19	17	13	-	20	17	13	-	20	17	13	-	20	17	13	-	19	17	13	-	18	16	12	-
kW	4.28	4.37	4.50	-	4.59	4.69	4.83	-	4.87	4.97	5.13	-	5.12	5.23	5.39	-	5.32	5.44	5.61	-	5.50	5.62	5.81	-	
Amps	18.2	18.6	19.1	-	19.5	19.9	20.4	-	20.9	21.4	22.0	-	22.2	22.6	23.3	-	23.4	23.9	24.6	-	24.7	25.2	26.0	-	
Hi PR	154	166	175	-	173	186	197	-	197	212	224	-	224	241	255	-	252	271	287	-	279	300	317	-	
Lo PR	61	65	71	-	65	69	75	-	67	72	78	-	71	75	82	-	74	79	86	-	77	82	89	-	
MBh	50.1	51.9	56.8	-	48.9	50.7	55.5	-	47.7	49.5	54.2	-	46.6	48.3	52.9	-	44.2	45.8	50.2	-	41.0	42.5	46.5	-	
S/T	0.69	0.58	0.40	-	0.72	0.60	0.42	-	0.74	0.61	0.43	-	0.76	0.63	0.44	-	0.79	0.66	0.46	-	0.80	0.66	0.46	-	
ΔT	20	17	13	-	20	17	13	-	20	17	13	-	20	17	13	-	20	17	13	-	19	16	12	-	
kW	4.18	4.27	4.39	-	4.49	4.58	4.72	-	4.76	4.86	5.01	-	4.99	5.10	5.26	-	5.20	5.31	5.48	-	5.37	5.49	5.66	-	
Amps	17.8	18.1	18.6	-	19.0	19.4	19.9	-	20.4	20.8	21.4	-	21.6	22.1	22.7	-	22.8	23.3	24.0	-	24.0	24.6	25.3	-	
Hi PR	150	161	170	-	168	181	191	-	191	206	217	-	217	234	247	-	245	263	278	-	270	291	307	-	
Lo PR	60	63	69	-	63	67	73	-	65	70	76	-	69	73	80	-	72	77	84	-	75	79	87	-	

75	MBh	56.8	58.5	63.3	67.9	55.5	57.1	61.8	66.4	54.2	55.8	60.4	64.8	52.8	54.4	58.9	63.2	50.2	51.7	55.9	60.0	46.5	47.9	51.8	55.6
	S/T	0.86	0.77	0.58	0.37	0.89	0.79	0.60	0.39	0.91	0.81	0.62	0.40	0.94	0.84	0.64	0.41	0.97	0.87	0.66	0.42	0.98	0.88	0.67	0.43
	ΔT	21	20	16	11	22	20	16	11	22	20	16	11	22	20	17	11	22	20	16	11	20	19	15	11
	kW	4.34	4.43	4.57	4.71	4.67	4.76	4.91	5.07	4.95	5.05	5.21	5.38	5.20	5.31	5.48	5.66	5.41	5.53	5.71	5.89	5.60	5.72	5.90	6.10
	Amps	18.5	18.9	19.4	20.0	19.8	20.2	20.8	21.4	21.2	21.7	22.3	23.1	22.5	23.0	23.7	24.5	23.8	24.3	25.1	25.9	25.1	25.6	26.4	27.3
	Hi PR	157	169	179	187	177	190	201	209	201	216	228	238	229	246	260	271	257	277	292	305	284	306	323	337
	Lo PR	63	67	73	78	66	70	77	82	69	73	80	85	72	77	84	89	76	81	88	94	78	83	91	97
	MBh	55.1	56.8	61.5	66.0	53.9	55.5	60.0	64.4	52.6	54.1	58.6	62.9	51.3	52.8	57.2	61.4	48.7	50.2	54.3	58.3	45.1	46.5	50.3	54.0
	S/T	0.82	0.73	0.55	0.36	0.85	0.76	0.57	0.37	0.87	0.78	0.59	0.38	0.90	0.80	0.61	0.39	0.93	0.83	0.63	0.40	0.94	0.84	0.63	0.41
	ΔT	22	21	17	12	23	21	17	12	23	21	17	12	23	21	17	12	23	21	17	12	21	19	16	11
kW	4.31	4.40	4.53	4.67	4.63	4.73	4.87	5.03	4.91	5.01	5.17	5.34	5.16	5.27	5.44	5.61	5.37	5.48	5.66	5.85	5.55	5.67	5.85	6.05	
Amps	18.3	18.7	19.2	19.9	19.6	20.0	20.6	21.3	21.1	21.5	22.2	22.9	22.3	22.8	23.5	24.3	23.6	24.1	24.9	25.7	24.9	25.4	26.2	27.1	
Hi PR	156	168	177	185	175	188	199	207	199	214	226	236	227	244	257	268	255	274	290	302	282	303	320	334	
Lo PR	62	66	72	77	66	70	76	81	68	73	79	84	72	76	83	89	75	80	87	93	78	83	90	96	
MBh	50.9	52.4	56.7	60.9	49.7	51.2	55.4	59.5	48.5	50.0	54.1	58.1	47.3	48.8	52.8	56.6	45.0	46.3	50.1	53.8	41.7	42.9	46.4	49.8	
S/T	0.79	0.70	0.53	0.34	0.82	0.73	0.55	0.36	0.84	0.75	0.57	0.36	0.86	0.77	0.58	0.38	0.90	0.80	0.61	0.39	0.90	0.81	0.61	0.39	
ΔT	23	21	17	12	23	21	17	12	23	21	17	12	23	21	18	12	23	21	17	12	21	20	16	11	
kW	4.21	4.30	4.43	4.56	4.52	4.61	4.76	4.91	4.79	4.89	5.05	5.21	5.03	5.14	5.30	5.47	5.24	5.35	5.52	5.70	5.41	5.53	5.71	5.90	
Amps	17.9	18.3	18.8	19.4	19.1	19.5	20.1	20.8	20.6	21.0	21.6	22.3	21.8	22.3	22.9	23.7	23.0	23.5	24.2	25.1	24.2	24.8	25.5	26.4	
Hi PR	151	163	172	179	170	183	193	201	193	208	219	229	220	236	250	260	247	266	281	293	273	294	310	324	
Lo PR	60	64	70	74	64	68	74	79	66	70	77	82	69	74	81	86	73	77	85	90	75	80	87	93	

Shaded area reflects ACCA (TVA) conditions IDB: Entering Indoor Dry Bulb Temperature kW = Total system power Amps = outdoor unit amps (comp.+fan)
 High and low pressures are measured at the liquid and suction service valves.

EXPANDED COOLING DATA — GPH1360M21A (CONT.)

IDB	Airflow	Outdoor Ambient Temperature																								
		65°F				75°F				85°F				95°F				105°F				115°F				
		59	63	67	71	59	63	67	71	59	63	67	71	59	63	67	71	59	63	67	71	59	63	67	71	
80	2081	MBh	57.8	59.1	63.1	67.5	56.5	57.7	61.6	65.9	55.1	56.3	60.2	64.3	53.8	55.0	58.7	62.8	51.1	52.2	55.8	59.6	47.3	48.4	51.7	55.2
		S/T	0.94	0.88	0.72	0.54	1.00	0.91	0.74	0.56	1.00	0.94	0.76	0.57	1.00	0.97	0.79	0.59	1.00	1.00	0.82	0.61	1.00	1.00	0.82	0.62
	ΔT	24	23	20	16	25	23	20	16	24	23	20	16	24	23	20	16	23	23	20	16	21	21	19	15	
	kW	4.38	4.47	4.60	4.75	4.70	4.80	4.95	5.11	4.99	5.09	5.25	5.42	5.24	5.35	5.52	5.70	5.46	5.57	5.75	5.94	5.64	5.76	5.95	6.15	
	Amps	18.6	19.0	19.5	20.2	19.9	20.3	20.9	21.6	21.4	21.9	22.5	23.3	22.7	23.2	23.9	24.7	24.0	24.5	25.3	26.1	25.3	25.8	26.6	27.6	
	Hi PR	159	171	181	188	178	192	203	211	203	218	231	240	231	249	263	274	260	280	295	308	287	309	326	340	
	Lo PR	63	67	74	78	67	71	78	83	70	74	81	86	73	78	85	90	77	81	89	95	79	84	92	98	
	MBh	56.1	57.4	61.3	65.5	54.8	56.0	59.9	64.0	53.5	54.7	58.4	62.5	52.2	53.4	57.0	60.9	49.6	50.7	54.2	57.9	45.9	46.9	50.2	53.6	
	S/T	0.90	0.84	0.68	0.51	0.93	0.87	0.71	0.53	0.95	0.89	0.73	0.54	0.98	0.92	0.75	0.56	1.00	0.96	0.78	0.58	1.00	0.96	0.78	0.59	
	ΔT	25	24	21	17	25	24	21	17	25	24	21	17	25	24	21	17	25	24	21	17	23	23	20	16	
kW	4.34	4.43	4.57	4.71	4.67	4.76	4.91	5.07	4.95	5.05	5.21	5.38	5.20	5.31	5.48	5.66	5.41	5.53	5.71	5.89	5.60	5.72	5.90	6.10		
Amps	18.5	18.9	19.4	20.0	19.8	20.2	20.8	21.4	21.2	21.7	22.3	23.1	22.5	23.0	23.7	24.5	23.8	24.3	25.1	25.9	25.1	25.6	26.4	27.3		
Hi PR	157	169	179	187	177	190	201	209	201	216	228	238	229	246	260	271	257	277	293	305	284	306	323	337		
Lo PR	63	67	73	78	66	70	77	82	69	73	80	85	72	77	84	89	76	81	88	94	78	83	91	97		
MBh	51.8	52.9	56.6	60.5	50.6	51.7	55.2	59.1	49.4	50.5	53.9	57.6	48.2	49.2	52.6	56.2	45.8	46.8	50.0	53.4	42.4	43.3	46.3	49.5		
S/T	0.86	0.81	0.66	0.49	0.90	0.84	0.68	0.51	0.92	0.86	0.70	0.52	0.95	0.89	0.72	0.54	0.98	0.92	0.75	0.56	0.99	0.93	0.76	0.57		
ΔT	25	24	21	17	26	25	21	17	26	25	21	17	26	25	22	17	26	25	21	17	24	23	20	16		
kW	4.25	4.33	4.46	4.60	4.56	4.65	4.79	4.94	4.83	4.93	5.09	5.25	5.07	5.18	5.35	5.52	5.28	5.39	5.57	5.75	5.46	5.58	5.76	5.95		
Amps	18.1	18.4	18.9	19.5	19.3	19.7	20.3	20.9	20.7	21.2	21.8	22.5	22.0	22.5	23.1	23.9	23.2	23.7	24.4	25.3	24.5	25.0	25.7	26.6		
Hi PR	153	164	174	181	171	184	195	203	195	210	221	231	222	239	252	263	250	269	284	296	276	297	313	327		
Lo PR	61	65	71	75	64	68	75	79	67	71	78	83	70	75	81	87	74	78	85	91	76	81	88	94		

85	2081	MBh	58.8	60.0	62.8	67.0	57.5	58.6	61.3	65.4	56.1	57.2	59.9	63.9	54.7	55.8	58.4	62.3	52.0	53.0	55.5	59.2	48.2	49.1	51.4	54.8
		S/T	0.98	0.95	0.86	0.70	1.00	0.98	0.89	0.72	1.00	1.00	0.91	0.74	1.00	1.00	0.94	0.76	1.00	1.00	0.98	0.79	1.00	1.00	0.98	0.80
	ΔT	26	25	24	21	25	25	24	21	25	25	24	21	24	25	24	21	24	25	24	21	21	21	22	19	
	kW	4.41	4.50	4.64	4.78	4.74	4.84	4.99	5.15	5.03	5.13	5.30	5.47	5.28	5.40	5.57	5.75	5.50	5.62	5.80	5.99	5.69	5.81	6.00	6.20	
	Amps	18.8	19.2	19.7	20.3	20.1	20.5	21.1	21.8	21.6	22.1	22.7	23.5	22.9	23.4	24.1	24.9	24.2	24.7	25.5	26.4	25.5	26.1	26.9	27.8	
	Hi PR	161	173	182	190	180	194	205	214	205	221	233	243	233	251	265	277	263	283	298	311	290	312	330	344	
	Lo PR	64	68	74	79	68	72	78	84	70	75	82	87	74	78	86	91	77	82	90	96	80	85	93	99	
	MBh	57.1	58.2	61.0	65.0	55.8	56.9	59.6	63.5	54.5	55.5	58.1	62.0	53.1	54.2	56.7	60.5	50.5	51.4	53.9	57.5	46.7	47.7	49.9	53.2	
	S/T	0.94	0.91	0.82	0.66	0.97	0.94	0.85	0.69	1.00	0.96	0.87	0.71	1.00	0.99	0.90	0.73	1.00	1.00	0.93	0.76	1.00	1.00	0.94	0.76	
	ΔT	27	26	25	21	27	27	25	22	27	27	25	22	26	27	25	22	25	26	25	22	23	24	23	20	
kW	4.38	4.47	4.60	4.75	4.70	4.80	4.95	5.11	4.99	5.09	5.25	5.42	5.24	5.35	5.52	5.70	5.46	5.57	5.75	5.94	5.64	5.76	5.95	6.15		
Amps	18.6	19.0	19.5	20.2	19.9	20.3	20.9	21.6	21.4	21.9	22.5	23.3	22.7	23.2	23.9	24.7	24.0	24.5	25.3	26.1	25.3	25.8	26.6	27.6		
Hi PR	159	171	181	188	178	192	203	211	203	218	231	240	231	249	263	274	260	280	295	308	287	309	326	340		
Lo PR	63	67	74	78	67	71	78	83	70	74	81	86	73	78	85	90	77	81	89	95	79	84	92	98		
MBh	52.7	53.7	56.3	60.0	51.5	52.5	55.0	58.6	50.3	51.2	53.7	57.2	49.0	50.0	52.3	55.8	46.6	47.5	49.7	53.1	43.1	44.0	46.1	49.1		
S/T	0.91	0.87	0.79	0.64	0.94	0.91	0.82	0.66	0.96	0.93	0.84	0.68	0.99	0.96	0.86	0.70	1.00	0.99	0.90	0.73	1.00	1.00	0.91	0.73		
ΔT	27	27	25	22	27	27	26	22	27	27	26	22	28	27	26	22	26	27	25	22	25	25	24	20		
kW	4.28	4.36	4.50	4.63	4.59	4.69	4.83	4.98	4.87	4.97	5.13	5.29	5.12	5.22	5.39	5.56	5.32	5.44	5.61	5.80	5.50	5.62	5.80	5.99		
Amps	18.2	18.6	19.1	19.7	19.4	19.9	20.4	21.1	20.9	21.3	22.0	22.7	22.2	22.6	23.3	24.1	23.4	23.9	24.6	25.5	24.7	25.2	26.0	26.9		
Hi PR	154	166	175	183	173	186	197	205	197	212	224	233	224	241	255	266	252	271	287	299	279	300	317	330		
Lo PR	61	65	71	76	65	69	75	80	67	72	78	83	71	75	82	88	74	79	86	92	77	82	89	95		

Shaded area reflects ARI conditions IDB: Entering Indoor Dry Bulb Temperature kW = Total system power Amps = outdoor unit amps (comp.+fan)
 High and low pressures are measured at the liquid and suction service valves.

COOLING DATA SUMMARY

GPH1324M21**

Indoor Air		Condenser Air Temperature														
		75°			85°			95°			105°			115°		
SCFM	WB	Total MBTU/h	Sens MBTU/h	Watts kWh	Total MBTU/h	Sens MBTU/h	Watts kWh	Total MBTU/h	Sens MBTU/h	Watts kWh	Total MBTU/h	Sens MBTU/h	Watts kWh	Total MBTU/h	Sens MBTU/h	Watts kWh
680	72	27.8	13.7	1.88	26.6	13.1	1.98	25.2	12.6	2.06	23.8	12.0	2.16	22.3	11.5	2.26
	67	25.4	16.9	1.76	24.2	16.4	1.84	23.0	15.8	1.94	21.6	15.3	2.04	20.2	15.3	2.14
	62	23.5	20.0	1.64	22.3	19.5	1.74	21.7	18.9	1.84	21.1	18.4	1.94	19.9	17.7	2.02
	57	22.6	21.7	1.60	21.6	20.7	1.70	20.6	19.8	1.80	19.4	18.7	1.92	18.5	17.7	2.00
800	72	29.0	15.1	1.94	27.6	14.6	2.02	26.2	14.0	2.12	24.7	13.7	2.22	23.0	12.9	2.32
	67	26.6	19.3	1.82	25.4	18.7	1.90	24.0	18.2	2.00	22.6	17.7	2.10	21.1	17.1	2.20
	62	24.7	23.1	1.72	23.5	22.4	1.80	22.3	21.5	1.90	21.4	20.4	2.00	20.2	19.3	2.12
	57	24.5	23.5	1.70	23.3	22.6	1.80	22.3	21.5	1.90	21.4	20.4	2.00	20.2	19.3	2.12
920	72	29.8	16.4	1.98	28.3	15.8	2.06	26.9	15.3	2.16	25.2	14.7	2.26	23.8	14.4	2.36
	67	27.6	21.3	1.86	26.2	20.9	1.94	24.7	20.4	2.04	23.3	19.7	2.14	21.8	19.1	2.24
	62	25.9	24.9	1.78	25.0	23.8	1.88	23.5	22.8	1.98	22.6	21.7	2.08	21.1	20.4	2.20
	57	25.9	24.9	1.78	25.0	23.8	1.88	23.5	22.8	1.98	22.6	21.7	2.08	21.1	20.4	2.20

Sensible heat capacities shown are based on 80°F DB entering air at the evaporator coil.
 For sensible heat capacities at other than 80°F DB, deduct 84 BTU/h per 100 CFM of evaporator coil air for each degree below 80°F, or add 84 BTU/h per 100 CFM of evaporator coil air per degree above 80°F.

Capacities at 95°F Outdoor, 75°F DB, and 63°F WB Indoor

Total MBTU/h **22.7** Sensible MBTU/h **17.5** Latent MBTU/h **5.2**

GPH1330M21**

Indoor Air		Condenser Air Temperature														
		75°			85°			95°			105°			115°		
SCFM	WB	Total MBTU/h	Sens MBTU/h	Watts kWh	Total MBTU/h	Sens MBTU/h	Watts kWh	Total MBTU/h	Sens MBTU/h	Watts kWh	Total MBTU/h	Sens MBTU/h	Watts kWh	Total MBTU/h	Sens MBTU/h	Watts kWh
680	72	34.8	17.3	2.35	33.3	16.6	2.48	31.5	15.9	2.58	29.7	15.2	2.70	27.9	14.5	2.83
	67	31.8	21.4	2.20	30.3	20.7	2.30	28.8	20.0	2.43	27.0	19.3	2.55	25.2	19.3	2.68
	62	29.4	25.3	2.05	27.9	24.6	2.18	27.2	23.9	2.30	26.4	23.2	2.43	24.9	22.3	2.53
	57	28.2	27.4	2.00	27.0	26.2	2.13	25.8	25.1	2.25	24.3	23.7	2.40	23.1	22.3	2.50
800	72	36.3	19.1	2.43	34.5	18.4	2.53	32.7	17.7	2.65	30.9	17.3	2.78	28.8	16.3	2.90
	67	33.3	24.4	2.28	31.8	23.7	2.38	30.0	23.0	2.50	28.2	22.3	2.63	26.4	21.6	2.75
	62	30.9	29.2	2.15	29.4	28.3	2.25	27.9	27.1	2.38	26.7	25.8	2.50	25.2	24.4	2.65
	57	30.6	29.7	2.13	29.1	28.5	2.25	27.9	27.1	2.38	26.7	25.8	2.50	25.2	24.4	2.65
920	72	37.2	20.7	2.48	35.4	20.0	2.58	33.6	19.3	2.70	31.5	18.6	2.83	29.7	18.2	2.95
	67	34.5	26.9	2.33	32.7	26.5	2.43	30.9	25.8	2.55	29.1	24.8	2.68	27.3	24.2	2.80
	62	32.4	31.5	2.23	31.2	30.1	2.35	29.4	28.8	2.48	28.2	27.4	2.60	26.4	25.8	2.75
	57	32.4	31.5	2.23	31.2	30.1	2.35	29.4	28.8	2.48	28.2	27.4	2.60	26.4	25.8	2.75

Sensible heat capacities shown are based on 80°F DB entering air at the evaporator coil.
 For sensible heat capacities at other than 80°F DB, deduct 84 BTU/h per 100 CFM of evaporator coil air for each degree below 80°F, or add 84 BTU/h per 100 CFM of evaporator coil air per degree above 80°F.

Capacities at 95°F Outdoor, 75°F DB, and 63°F WB Indoor

Total MBTU/h **28.3** Sensible MBTU/h **22.1** Latent MBTU/h **6.2**

COOLING DATA SUMMARY (CONT.)

GPH1336M21**

Indoor Air		Condenser Air Temperature														
		75°			85°			95°			105°			115°		
SCFM	WB	Total MBTU/h	Sens MBTU/h	Watts kWh	Total MBTU/h	Sens MBTU/h	Watts kWh	Total MBTU/h	Sens MBTU/h	Watts kWh	Total MBTU/h	Sens MBTU/h	Watts kWh	Total MBTU/h	Sens MBTU/h	Watts kWh
1009	72	41.3	20.1	2.79	39.5	19.3	2.94	37.4	18.5	3.06	35.2	17.7	3.20	33.1	16.9	3.35
	67	37.7	24.9	2.61	36.0	24.1	2.73	34.2	23.3	2.88	32.0	22.5	3.03	29.9	22.5	3.17
	62	34.9	29.5	2.43	33.1	28.7	2.58	32.2	27.9	2.73	31.3	27.1	2.88	29.5	26.0	3.00
	57	33.5	31.9	2.37	32.0	30.6	2.52	30.6	29.2	2.67	28.8	27.6	2.85	27.4	26.0	2.97
1187	72	43.1	22.2	2.88	40.9	21.4	3.00	38.8	20.6	3.14	36.7	20.1	3.29	34.2	19.0	3.44
	67	39.5	28.4	2.70	37.7	27.6	2.82	35.6	26.8	2.97	33.5	26.0	3.12	31.3	25.2	3.26
	62	36.7	34.0	2.55	34.9	33.0	2.67	33.1	31.6	2.82	31.7	30.0	2.97	29.9	28.4	3.14
	57	36.3	34.6	2.52	34.5	33.2	2.67	33.1	31.6	2.82	31.7	30.0	2.97	29.9	28.4	3.14
1365	72	44.1	24.1	2.94	42.0	23.3	3.06	39.9	22.5	3.20	37.4	21.7	3.35	35.2	21.2	3.50
	67	40.9	31.4	2.76	38.8	30.8	2.88	36.7	30.0	3.03	34.5	28.9	3.17	32.4	28.1	3.32
	62	38.4	36.7	2.64	37.0	35.1	2.79	34.9	33.5	2.94	33.5	31.9	3.09	31.3	30.0	3.26
	57	38.4	36.7	2.64	37.0	35.1	2.79	34.9	33.5	2.94	33.5	31.9	3.09	31.3	30.0	3.26

Total MBTU/h **33.6** Sensible MBTU/h **25.7** Latent MBTU/h **7.9**

GPH1348M21**

Indoor Air		Condenser Air Temperature														
		75°			85°			95°			105°			115°		
SCFM	WB	Total MBTU/h	Sens MBTU/h	Watts kWh	Total MBTU/h	Sens MBTU/h	Watts kWh	Total MBTU/h	Sens MBTU/h	Watts kWh	Total MBTU/h	Sens MBTU/h	Watts kWh	Total MBTU/h	Sens MBTU/h	Watts kWh
1360	72	55.7	27.5	3.76	53.3	26.4	3.96	50.4	25.3	4.12	47.5	24.2	4.32	44.6	23.1	4.52
	67	50.9	34.0	3.52	48.5	32.9	3.68	46.1	31.8	3.88	43.2	30.7	4.08	40.3	30.7	4.28
	62	47.0	40.3	3.28	44.6	39.2	3.48	43.4	38.1	3.68	42.2	37.0	3.88	39.8	35.5	4.04
	57	45.1	43.6	3.20	43.2	41.7	3.40	41.3	39.9	3.60	38.9	37.7	3.84	37.0	35.5	4.00
1600	72	58.1	30.4	3.88	55.2	29.3	4.04	52.3	28.2	4.24	49.4	27.5	4.44	46.1	26.0	4.64
	67	53.3	38.8	3.64	50.9	37.7	3.80	48.0	36.6	4.00	45.1	35.5	4.20	42.2	34.4	4.40
	62	49.4	46.5	3.44	47.0	45.0	3.60	44.6	43.2	3.80	42.7	41.0	4.00	40.3	38.8	4.24
	57	49.0	47.2	3.40	46.6	45.4	3.60	44.6	43.2	3.80	42.7	41.0	4.00	40.3	38.8	4.24
1840	72	59.5	32.9	3.96	56.6	31.8	4.12	53.8	30.7	4.32	50.4	29.6	4.52	47.5	28.9	4.72
	67	55.2	42.8	3.72	52.3	42.1	3.88	49.4	41.0	4.08	46.6	39.5	4.28	43.7	38.4	4.48
	62	51.8	50.1	3.56	49.9	47.9	3.76	47.0	45.8	3.96	45.1	43.6	4.16	42.2	41.0	4.40
	57	51.8	50.1	3.56	49.9	47.9	3.76	47.0	45.8	3.96	45.1	43.6	4.16	42.2	41.0	4.40

Total MBTU/h **45.3** Sensible MBTU/h **35.2** Latent MBTU/h **10.2**

GPH1360M21**

Indoor Air		Condenser Air Temperature														
		75°			85°			95°			105°			115°		
SCFM	WB	Total MBTU/h	Sens MBTU/h	Watts kWh	Total MBTU/h	Sens MBTU/h	Watts kWh	Total MBTU/h	Sens MBTU/h	Watts kWh	Total MBTU/h	Sens MBTU/h	Watts kWh	Total MBTU/h	Sens MBTU/h	Watts kWh
1601	72	65.5	32.1	4.43	62.7	30.8	4.66	59.3	29.5	4.85	55.9	28.2	5.09	52.5	27.0	5.32
	67	59.9	39.8	4.14	57.1	38.5	4.33	54.2	37.2	4.57	50.9	36.0	4.80	47.5	36.0	5.04
	62	55.4	47.1	3.86	52.5	45.8	4.10	51.1	44.5	4.33	49.7	43.2	4.57	46.9	41.5	4.76
	57	53.1	50.9	3.77	50.9	48.8	4.00	48.6	46.7	4.24	45.8	44.1	4.52	43.5	41.5	4.71
1883	72	68.4	35.5	4.57	65.0	34.2	4.76	61.6	33.0	4.99	58.2	32.1	5.23	54.2	30.4	5.46
	67	62.7	45.4	4.28	59.9	44.1	4.47	56.5	42.8	4.71	53.1	41.5	4.94	49.7	40.2	5.18
	62	58.2	54.4	4.05	55.4	52.6	4.24	52.5	50.5	4.47	50.3	47.9	4.71	47.5	45.4	4.99
	57	57.6	55.2	4.00	54.8	53.1	4.24	52.5	50.5	4.47	50.3	47.9	4.71	47.5	45.4	4.99
2166	72	70.1	38.5	4.66	66.7	37.2	4.85	63.3	36.0	5.09	59.3	34.7	5.32	55.9	33.8	5.56
	67	65.0	50.1	4.38	61.6	49.2	4.57	58.2	47.9	4.80	54.8	46.2	5.04	51.4	44.9	5.27
	62	61.0	58.6	4.19	58.8	56.1	4.43	55.4	53.5	4.66	53.1	50.9	4.90	49.7	47.9	5.18
	57	61.0	58.6	4.19	58.8	56.1	4.43	55.4	53.5	4.66	53.1	50.9	4.90	49.7	47.9	5.18

Total MBTU/h **53.3** Sensible MBTU/h **41.1** Latent MBTU/h **12.3**

EXPANDED HEATING DATA

GPH1324M21*

	Outdoor Ambient Temperature																	
	65	60	55	50	47	45	40	35	30	25	20	17	15	10	5	0	-5	-10
MBh	27.7	26.2	24.6	23.0	22.0	21.3	19.8	18.3	15.5	14.3	13.1	12.4	11.9	10.7	9.5	8.3	7.1	5.8
ΔT	28.5	26.9	25.3	23.7	22.6	21.9	20.4	18.8	15.9	14.7	13.5	12.8	12.3	11.0	9.8	8.5	7.3	6.0
kW	2.01	1.98	1.94	1.91	1.89	1.88	1.84	1.81	1.82	1.79	1.75	1.73	1.72	1.68	1.64	1.61	1.57	1.54
Amps	10.3	9.6	9.0	8.6	8.3	8.2	7.8	7.4	7.1	6.9	6.6	6.5	6.4	6.1	5.8	5.5	5.2	4.8
COP	4.02	3.87	3.71	3.53	3.41	3.33	3.15	2.96	2.48	2.34	2.19	2.10	2.04	1.87	1.69	1.51	1.32	1.10
EER	13.7	13.2	12.7	12.1	11.6	11.4	10.7	10.1	8.5	8.0	7.5	7.2	7.0	6.4	5.8	5.1	4.5	3.8
Hi PR	232	223	214	205	200	196	189	181	173	166	159	155	152	147	141	135	130	126
Lo PR	78	73	68	62	59	57	52	46	42	37	33	31	30	25	22	18	16	12

GPH1330M21*

	Outdoor Ambient Temperature																	
	65	60	55	50	47	45	40	35	30	25	20	17	15	10	5	0	-5	-10
MBh	36.7	34.7	32.7	30.6	29.2	28.3	26.3	24.2	19.9	18.4	16.9	16.0	15.4	13.8	12.3	10.7	9.1	7.5
ΔT	32.4	30.6	28.8	27.0	25.7	25.0	23.2	21.4	17.6	16.2	14.9	14.1	13.6	12.2	10.8	9.4	8.0	6.6
kW	2.87	2.81	2.76	2.70	2.67	2.65	2.59	2.54	2.37	2.31	2.26	2.23	2.21	2.16	2.10	2.05	2.00	1.95
Amps	13.0	12.0	11.2	10.6	10.2	10.0	9.4	8.9	8.5	8.1	7.7	7.5	7.4	7.1	6.6	6.2	5.7	5.1
COP	3.74	3.61	3.47	3.31	3.20	3.13	2.97	2.80	2.47	2.33	2.19	2.10	2.04	1.88	1.70	1.52	1.33	1.12
EER	12.8	12.3	11.9	11.3	10.9	10.7	10.1	9.6	8.4	8.0	7.5	7.2	7.0	6.4	5.8	5.2	4.6	3.8
Hi PR	260	250	240	229	224	220	211	203	194	186	178	174	171	164	158	151	146	141
Lo PR	79	73	68	63	59	57	52	47	42	38	33	31	30	25	22	18	16	12

GPH1336M21*

	Outdoor Ambient Temperature																	
	65	60	55	50	47	45	40	35	30	25	20	17	15	10	5	0	-5	-10
MBh	43.0	40.7	38.3	35.8	34.2	33.1	30.8	28.4	23.2	21.4	19.7	18.6	17.9	16.1	14.2	12.4	10.6	8.7
ΔT	33.2	31.4	29.6	27.6	26.4	25.6	23.8	21.9	17.9	16.5	15.2	14.4	13.8	12.4	11.0	9.6	8.2	6.7
kW	3.16	3.10	3.04	2.98	2.95	2.92	2.86	2.80	2.75	2.69	2.63	2.60	2.57	2.51	2.45	2.39	2.33	2.27
Amps	15.9	14.8	14.0	13.2	12.8	12.6	11.9	11.4	11.0	10.6	10.1	9.9	9.8	9.4	8.8	8.4	7.9	7.2
COP	3.98	3.84	3.69	3.52	3.40	3.32	3.15	2.97	2.47	2.33	2.19	2.10	2.04	1.87	1.70	1.52	1.33	1.12
EER	13.6	13.1	12.6	12.0	11.6	11.4	10.8	10.1	8.4	8.0	7.5	7.2	7.0	6.4	5.8	5.2	4.5	3.8
Hi PR	244	234	225	215	210	206	198	190	182	174	167	163	160	154	148	142	137	132
Lo PR	77	71	67	61	58	56	51	46	41	37	32	30	29	25	21	18	16	12

Above information is for nominal CFM and 70 degree indoor dry bulb. Instantaneous capacity listed.

EXPANDED HEATING DATA (CONT.)

GPB1348M21*

	Outdoor Ambient Temperature																	
	65	60	55	50	47	45	40	35	30	25	20	17	15	10	5	0	-5	-10
MBh	56.6	53.6	50.4	47.1	45.0	43.6	40.5	37.4	31.2	28.8	26.5	25.0	24.1	21.6	19.2	16.7	14.3	11.7
ΔT	29.9	28.3	26.7	24.9	23.8	23.1	21.4	19.8	16.5	15.2	14.0	13.2	12.7	11.4	10.1	8.8	7.5	6.2
kW	4.04	3.97	3.89	3.81	3.77	3.74	3.66	3.59	3.53	3.45	3.37	3.33	3.30	3.22	3.15	3.07	3.00	2.92
Amps	21.7	20.4	19.3	18.4	17.9	17.6	16.9	16.2	15.7	15.1	14.6	14.3	14.2	13.7	13.0	12.5	11.8	11.0
COP	4.10	3.95	3.79	3.62	3.49	3.41	3.23	3.05	2.59	2.44	2.30	2.20	2.13	1.96	1.78	1.59	1.39	1.17
EER	14.0	13.5	13.0	12.4	11.9	11.7	11.1	10.4	8.8	8.3	7.8	7.5	7.3	6.7	6.1	5.4	4.8	4.0
Hi PR	232	223	214	205	200	196	189	181	173	166	159	155	152	147	141	135	130	126
Lo PR	76	70	66	60	57	55	50	45	41	36	32	30	29	24	21	18	15	12

GPB1360M21*

	Outdoor Ambient Temperature																	
	65	60	55	50	47	45	40	35	30	25	20	17	15	10	5	0	-5	-10
MBh	69.1	65.5	61.6	57.6	55.0	53.3	49.5	45.7	38.4	35.4	32.6	30.8	29.7	26.6	23.6	20.6	17.6	14.4
ΔT	34.6	32.8	30.8	28.8	27.5	26.7	24.8	22.8	19.2	17.7	16.3	15.4	14.8	13.3	11.8	10.3	8.8	7.2
kW	5.09	4.99	4.89	4.80	4.74	4.70	4.61	4.51	4.56	4.46	4.36	4.30	4.26	4.16	4.06	3.96	3.86	3.76
Amps	26.3	24.5	23.1	21.9	21.2	20.8	19.8	18.9	18.2	17.5	16.8	16.5	16.3	15.6	14.7	14.0	13.1	12.1
COP	3.98	3.84	3.69	3.51	3.40	3.32	3.14	2.96	2.46	2.33	2.19	2.10	2.04	1.87	1.70	1.52	1.33	1.12
EER	13.6	13.1	12.6	12.0	11.6	11.3	10.7	10.1	8.4	7.9	7.5	7.2	7.0	6.4	5.8	5.2	4.5	3.8
Hi PR	244	234	225	215	210	206	198	190	182	174	167	163	160	154	148	142	137	132
Lo PR	73	68	63	58	55	53	49	43	39	35	31	29	28	23	20	17	15	12

Above information is for nominal CFM and 70 degree indoor dry bulb. Instantaneous capacity listed.

HEAT KIT ELECTRICAL DATA (BLOWER ONLY, HEAT MODE)

Model & Heat Kit Usage	Circuit #1		Circuit #2		Actual kW / BTU @ 240V
	MCA ¹	MOP ²	MCA ¹	MOP ²	
GPH1324M21AA	1.5 / 1.5	--	--	--	--
HKR-05*, HKR-05C*	24 / 27	30 / 30	--	--	4.75 / 16,200
HKR-08*, HKR-08C*	34 / 39	40 / 40	--	--	7.0 / 23,800
HKR-10*, HKR-10C*	45 / 52	60 / 60	--	--	9.5 / 32,400
GPH1330M21AA	1.5 / 1.5	--	--	--	--
HKR-05*, HKR-05C*	24 / 27	30 / 30	--	--	4.75 / 16,200
HKR-08*, HKR-08C*	34 / 39	40 / 40	--	--	7.0 / 23,800
HKR-10*, HKR-10C*	45 / 52	60 / 60	--	--	9.5 / 32,400
HKR-15*, HKR-15C*	45 / 52	60 / 60	22 / 25	30 / 30	14.25 / 48,600
GPH1336M21AA	1.9 / 1.9	--	--	--	--
HKR-05*, HKR-05C*	24 / 27	30 / 30	--	--	4.75 / 16,200
HKR-08*, HKR-08C*	34 / 39	40 / 40	--	--	7.0 / 23,800
HKR-10*, HKR-10C*	45 / 52	60 / 60	--	--	9.5 / 32,400
HKR-15*, HKR-15C*	45 / 52	60 / 60	22 / 25	30 / 30	14.25 / 48,600
GPH1348M21AA	5.8 / 5.8	--	--	--	--
HKR-05*, HKR-05C*	25 / 28	30 / 30	--	--	4.75 / 16,200
HKR-08*, HKR-08C*	38 / 40	40 / 40	--	--	7.0 / 23,800
HKR-10*, HKR-10C*	49 / 56	60 / 60	--	--	9.5 / 32,400
HKR-15*, HKR-15C*	49 / 56	60 / 60	22 / 25	30 / 30	14.25 / 48,600
HKR-20*, HKR-20C*	49 / 56	60 / 60	43 / 49	60 / 60	19.5 / 66,500
GPH1360M21AA	7.6 / 7.6	--	--	--	--
HKR-05*, HKR-05C*	29 / 30	30 / 30	--	--	4.75 / 16,200
HKR-08*, HKR-08C*	39 / 40	40 / 40	--	--	7.0 / 23,800
HKR-10*, HKR-10C*	51 / 58	60 / 60	--	--	9.5 / 32,400
HKR-15*, HKR-15C*	51 / 58	60 / 60	22 / 25	30 / 30	14.25 / 48,600
HKR-20*, HKR-20C*	51 / 58	60 / 60	43 / 49	60 / 60	19.5 / 66,500

¹ Minimum Circuit Ampacity @ 208 / 240 V

² Maximum Overcurrent Protection device @ 208 / 240 V

* Revision level that may or may not be designated

C Circuit Breaker option

DIMENSIONS

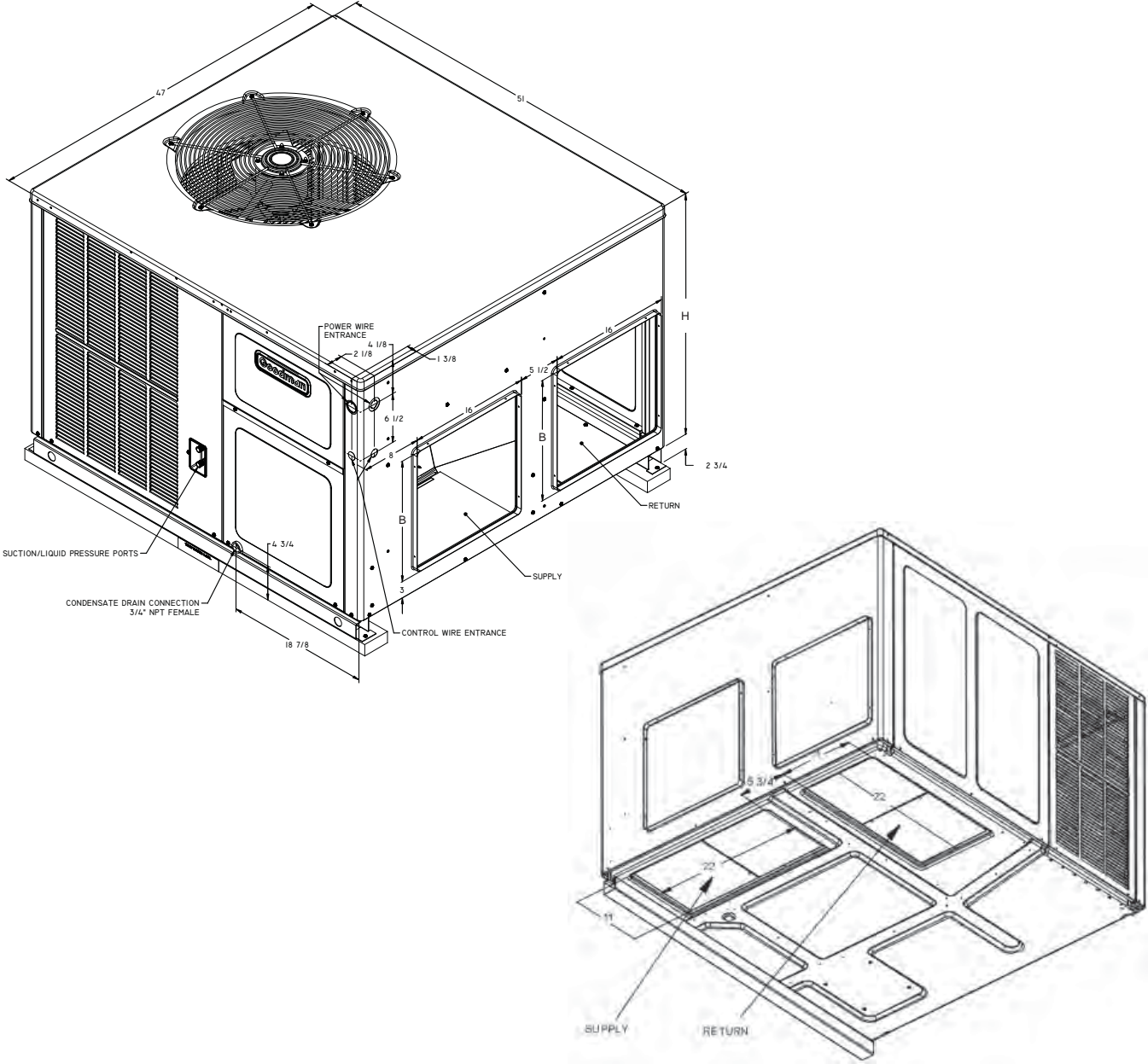

DIMENSIONS

Model	Med.	Large	H x D x W	B	H
GPH1324M21A	X		34 ³ / ₄ " x 51" x 47"	16"	32 ¹ / ₂ "
GPH1330M21A	X		34 ³ / ₄ " x 51" x 47"	16"	32 ¹ / ₂ "
GPH1336M21A	X		34 ³ / ₄ " x 51" x 47"	16"	32 ¹ / ₂ "
GPH1348M21A		X	42 ³ / ₄ " x 51" x 47"	18"	40"
GPH1360M21A		X	42 ³ / ₄ " x 51" x 47"	18"	40"

FILTERS

Model	Dimensions	Qty.
GPH13MFR102 (for medium models)	16" x 25" x 2"	1
GPH13MFR103 (for large models)	20" x 25" x 2"	1

WIRING DIAGRAM — GPH1324-48M21A*

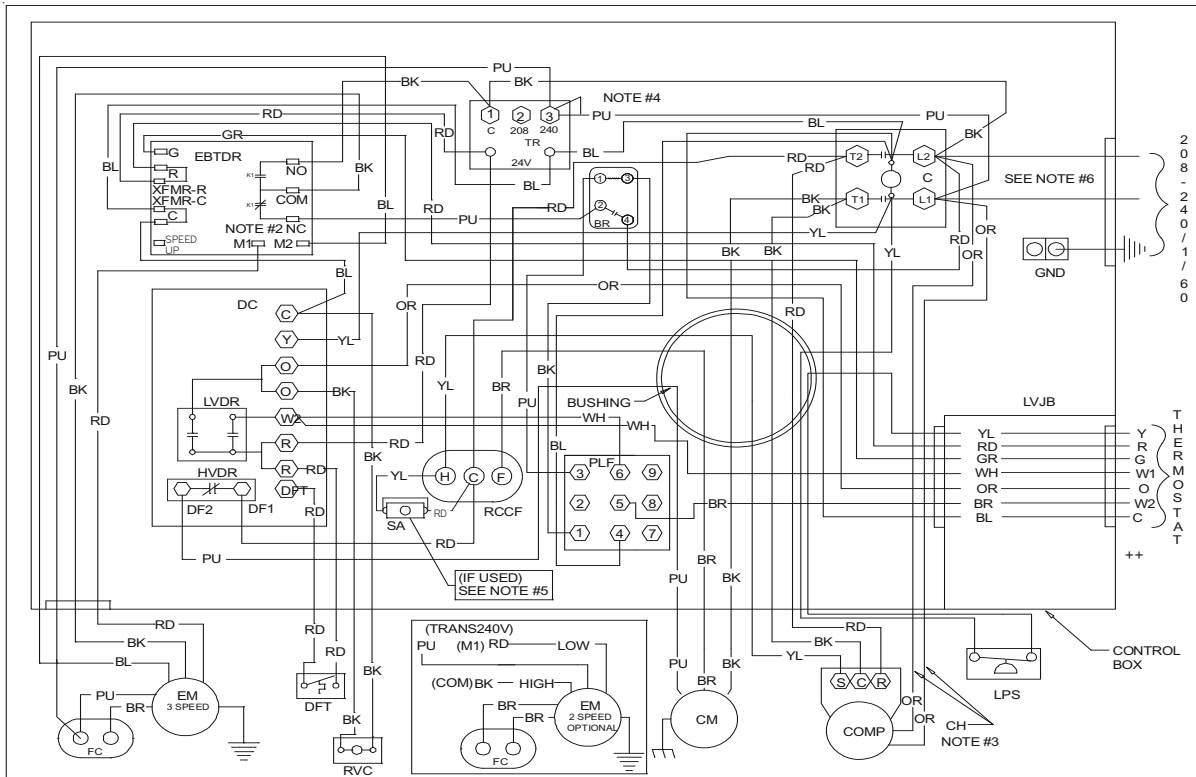

Wiring is subject to change. Always refer to the wiring diagram on the unit for the most up-to-date schematic.

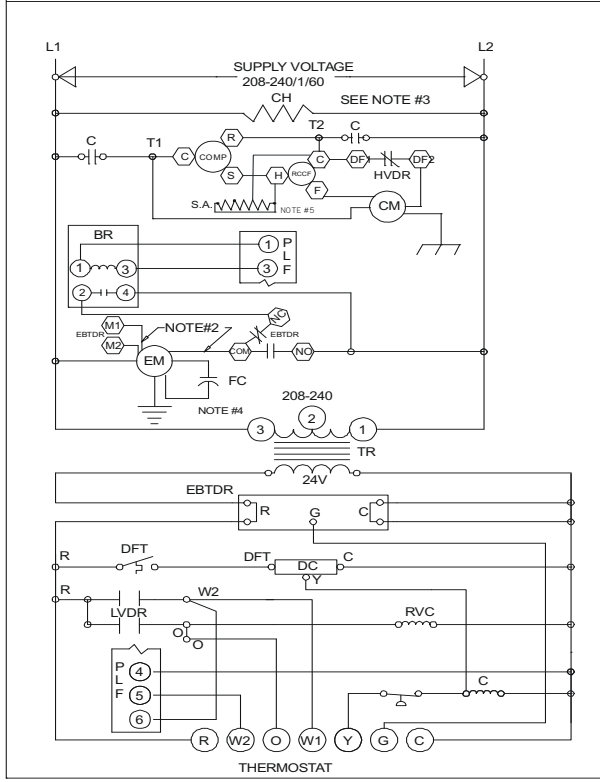

COMPONENT LEGEND		FACTORY WIRING
BR	BLOWER INTERLOCK RELAY	— LINE VOLTAGE
C	CONTACTOR	— LOW VOLTAGE
CH	CRANKCASE HEATER	— OPTIMAL HIGH VOLTAGE
CM	CONDENSER MOTOR	— VOLTAGE
COMP	COMPRESSOR	
DC	DEFROST CONTROL	FIELD WIRING
DFT	DEFROST THERMOSTAT	— HIGH VOLTAGE
EBTD	ELECTRONIC BLOWER TIME DELAY RELAY	— LOW VOLTAGE
R	RELAY	
EM	EVAPORATOR MOTOR	
FC	FAN CAPACITOR	
GND	EQUIPMENT GROUND	
HVDR	HIGH VOLTAGE DEFROST RELAY	
LPS	LOW PRESSURE SWITCH	
LVDR	LOW VOLTAGE DEFROST RELAY	
LVJB	LOW VOLTAGE JUNCTION BOX	
PLF	FEMALE PLUG / CONNECTOR	
RVC	REVERSING VALVE COIL	
RCCF	RUN CAPACITOR FOR COMPRESSOR AND FAN	
SA	START ASSIST	
TR	TRANSFORMER	

- NOTES:**
- REPLACEMENT WIRE MUST BE SAME SIZE AND TYPE INSULATION AS ORIGINAL (AT LEAST 105°C) USE COPPER CONDUCTOR ONLY.
 - TO CHANGE EVAPORATOR MOTOR SPEED REPLACE LEAD ON EBTD "COM" WITH LEAD ON EBTD "M1" OR "M2"
 - CRANKCASE HEAT NOT SUPPLIED ON ALL UNITS.
 - FOR 208 VOLT TRANSFORMER OPERATION MOVE PURPLE WIRES FROM TERMINAL 3 TERMINAL 2 ON TRANSFORMER.
 - START ASSIST FACTOR EQUIPPED WHEN REQUIRED
 - USE COPPER CONDUCTORS ONLY
 - USE N.E.C. CLASS 2 WIRE

SEE UNIT RATING PLATE FOR TYPE AND SIZE OF OVER CURRENT PROTECTION

208-240/1/60 0140G00365 REV. B

WARNING High Voltage: Disconnect all power before servicing or installing this unit. Multiple power sources may be present. Failure to do so may cause property damage, personal injury, or death.

WIRING DIAGRAM — GPH1360M21A*

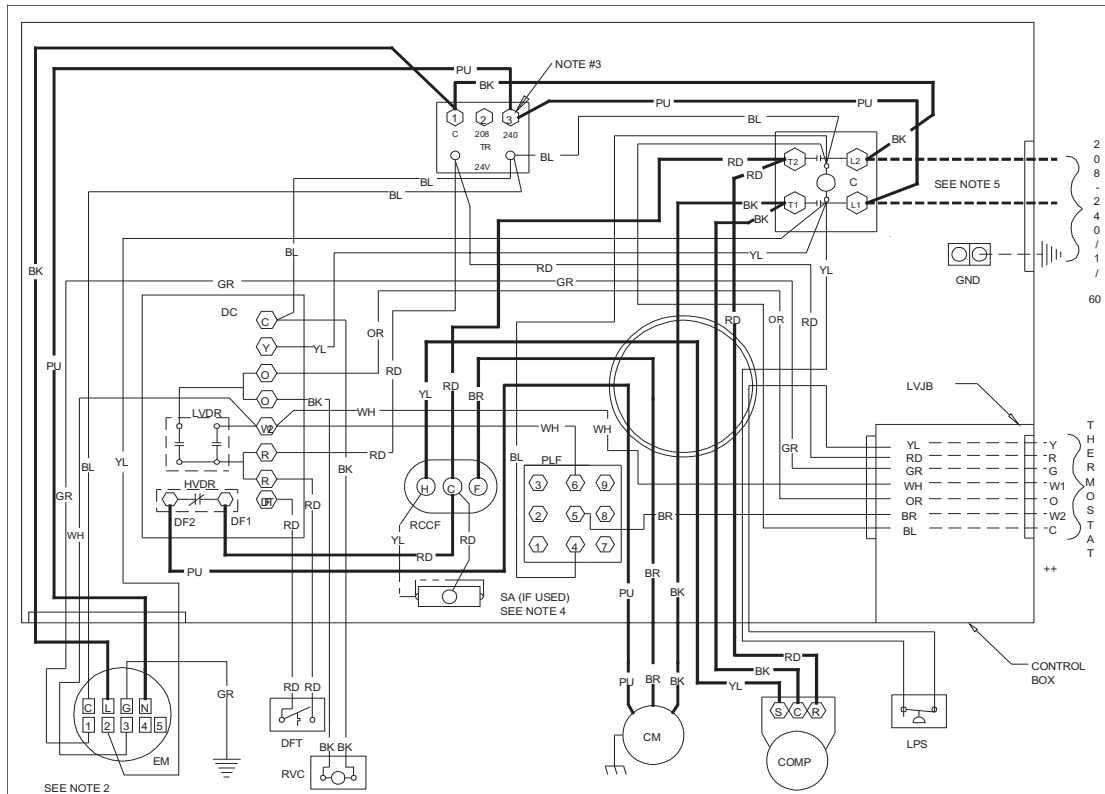

High Voltage: Disconnect all power before servicing or installing this unit. Multiple power sources may be present. Failure to do so may cause property damage, personal injury, or death.

WARNING

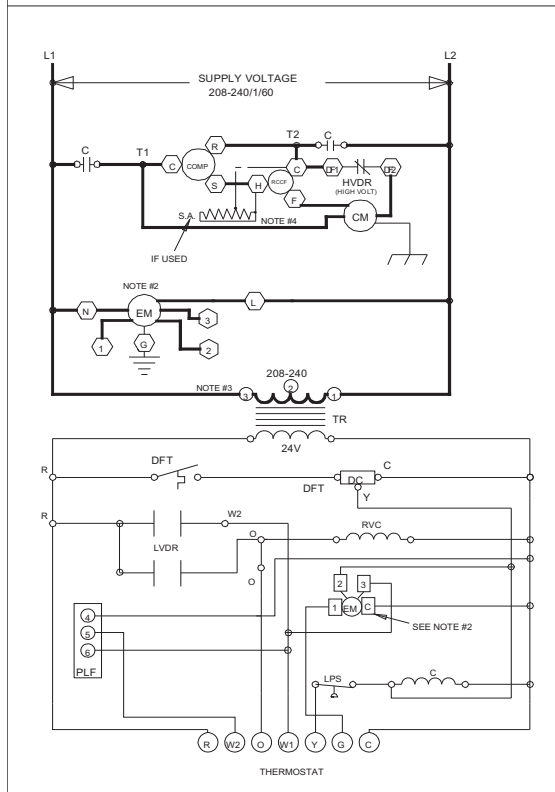

COMPONENT LEGEND		FACTORY WIRING	
C	CONTACTOR	—	LINE VOLTAGE
CM	CONDENSER MOTOR	—	LOW VOLTAGE
COMP	COMPRESSOR	—	OPTIMAL HIGH VOLTAGE
DC	DEFROST CONTROL	—	VOLTAGE
DFT	DEFROST THERMOSTAT	—	FIELD WIRING
EM	EVAPORATOR MOTOR	—	HIGH VOLTAGE
GND	EQUIPMENT GROUND	—	LOW VOLTAGE
HVDR	HIGH VOLTAGE DEFROST RELAY		
LPS	LOW PRESSURE SWITCH		
LVDR	LOW VOLTAGE DEFROST RELAY		
LVJB	LOW VOLTAGE JUNCTION BOX		
PLF	FEMALE PLUG / CONNECTOR		
RVC	REVERSING VALVE COIL		
RCCF	RUN CAPACITOR FOR COMPRESSOR AND FAN		
SA	START ASSIST		
TR	TRANSFORMER		

WIRE CODE	
BK	BLACK
BL	BLUE
BR	BROWN
GR	GREEN
OR	ORANGE
PU	PURPLE
RD	RED
WH	WHITE
YL	YELLOW

NOTES:

- REPLACEMENT WIRE MUST BE SAME SIZE AND TYPE INSULATION AS ORIGINAL (AT LEAST 105°C) USE COPPER CONDUCTOR ONLY.
- TO CHANGE EVAPORATOR MOTOR SPEED MOVE WHITE AND YELLOW LEADS FROM EM"2" AND "3" TO "4" AND "5". IF BOTH LEADS ARE ENERGIZED, THE HIGHER SPEED SETTING IS USED.
- FOR 208 VOLT TRANSFORMER OPERATION MOVE PURPLE WIRES FROM TERMINAL 3 TO TERMINAL 2 ON TRANSFORMER
- START ASSIST FACTOR EQUIPPED WHEN REQUIRED
- USE COPPER CONDUCTORS ONLY

++ USE N.E.C. CLASS 2 WIRE

SEE UNIT RATING PLATE FOR TYPE AND SIZE OF OVER CURRENT PROTECTION

208-240/1/60 0140G00408

Wiring is subject to change. Always refer to the wiring diagram on the unit for the most up-to-date schematic.

ACCESSORIES

Item	Description
20464501PDGK	Horizontal Duct Cover for Medium Chassis
20464502PDGK	Horizontal Duct Cover for Large Chassis
GPH13MED102/ 103	Downflow Economizer for Medium/Large Chassis
GPH13MFR102/ 103	Internal filter rack for Downflow Applications — Medium/ Large Chassis
OT/EHR18-60	Emergency Heat Relay kit
OT18-60A	Outdoor Thermostat Kit with Lockout Stat
PGC102/ 103	Roof Curb for Medium/ Large Chassis
PGMDD102	Manual Damper for Downflow Application — Medium Chassis
PGMDD103	Manual Damper for Downflow Application — Large Chassis
PGMDH102	Manual 25% Fresh Air Damper for Horizontal Applications — Medium Chassis
PGMDH103	Manual 25% Fresh Air Damper for Horizontal Applications — Large Chassis
PGMDMD102	Motorized Damper for Downflow Application — Medium Chassis
PGMDMD103	Motorized Damper for Downflow Application — Large Chassis
PGMDMH102	Motorized 25% Fresh Air Damper for Horizontal Applications — Medium Chassis
PGMDMH103	Motorized 25% Fresh Air Damper for Horizontal Applications — Large Chassis
SQRPG102	Square-to-Round Adapter with 16" Round for Downflow Applications — Medium Chassis
SQRPG103	Square-to-Round Adapter with 18" Round for Downflow Applications — Large Chassis
SQRPGH102	Square-to-Round Adapters for Medium Chassis — 16" x 14"
SQRPGH103	Square-to-Round Adapters for Large Chassis — 18" x 14"

