



Air Conditioning & Heating

PRODUCT SPECIFICATIONS



13 SEER

3-, 4-, & 5-TON, THREE-PHASE

COOLING CAPACITY: 35,600 - 56,500 BTU/h

HEATING CAPACITY: 34,200 - 55,000 BTU/h



GPH13M COMMERCIAL PACKAGED HEAT PUMP

The Goodman® GPH13M Commercial Packaged Heat Pump features energy-efficient cooling and heating performance in one self-contained unit. This unit is housed in a heavy-gauge, galvanized-steel cabinet protected by a high-quality, UV-resistant powder-paint finish and allows for a ground-level or rooftop mount.

Standard Features

- Energy-efficient compressor with internal relief valve
- EEM blower motor; PSC blower motor on 3-ton units
- Convertible airflow — horizontal or downflow
- Copper tube/aluminum fin coil
- Totally enclosed, permanently lubricated condenser fan motor
- Fully charged R-22 system
- Electric heat kit available as a field-installed accessory



Cabinet Features

- Heavy-gauge galvanized-steel cabinet
- Attractive Architectural Gray powder-paint finish
- Fully insulated blower compartment with convenient access panels
- Louvered condenser coil protection
- One footprint; two heights

Contents

Nomenclature.....	2
Product Specifications.....	3
Evaporator Blower Specifications.....	4
Expanded Cooling Data.....	6
Expanded Heating Data.....	18
Heat Kit Electrical Data.....	20
Dimensions.....	21
Wiring Diagrams	22
Accessories	24

NOMENCLATURE

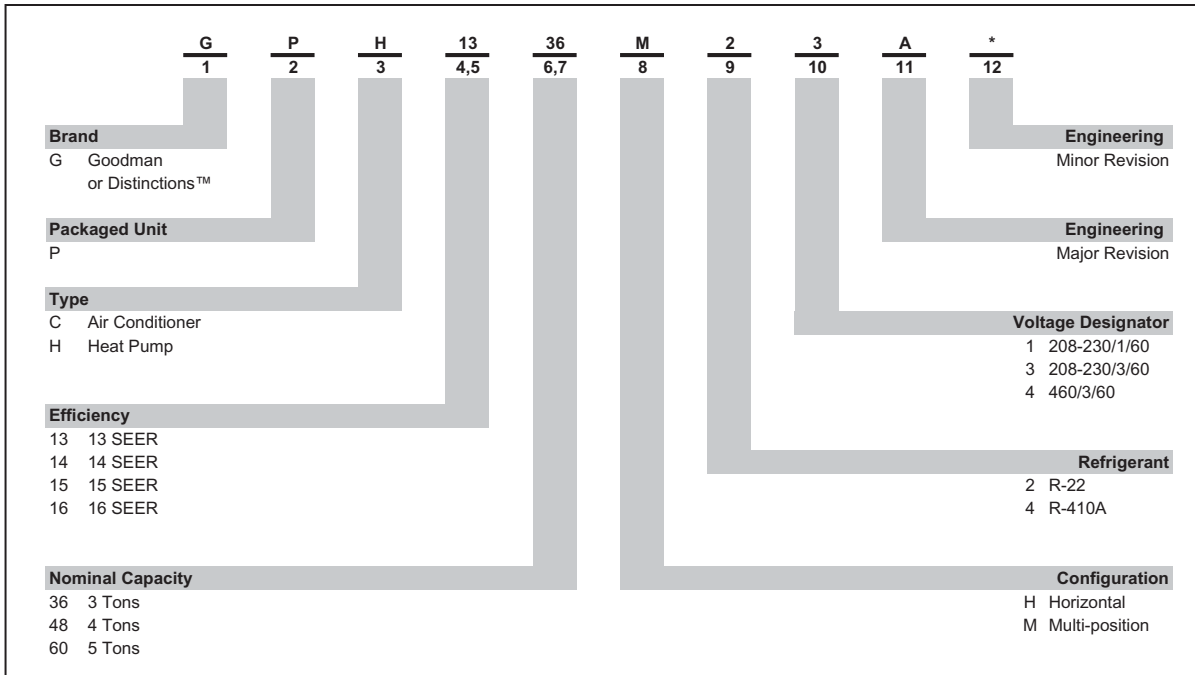

SPECIFICATIONS

	GPH13 36M23AA	GPH13 36M24AA	GPH13 48M23AA	GPH13 48M24AA	GPH13 60M23AA	GPH13 60M24AA
Cooling Capacity						
Total BTU/h	35,600	35,600	48,000	48,000	56,500	56,500
Sensible BTU/h	26,800	26,800	36,600	36,600	42,800	42,800
SEER / EER	13 / 11.3	13 / 11.3	13 / 11.3	13 / 11.3	13 / 10.4	13 / 10.4
Decibels	79	79	80	80	80	80
Heating Capacity						
BTU/h (47°F)	34,200	34,200	45,000	45,000	55,000	55,000
COP (47°F)	3.4	3.4	3.5	3.5	3.4	3.4
BTU/h (17°F)	18,600	18,600	25,000	25,000	31,000	31,000
COP (17°F)	2.1	2.1	2.2	2.2	2.1	2.1
HSPF	7.8	7.8	8.0	8.0	7.7	7.7
Evaporator Motor						
Type	DD	DD	DD	DD	DD	DD
Nominal Cooling CFM	1,200	1,200	1,725	1,725	1,850	1,850
Wheel (DxW)	10 X 9	10 X 9	10 X 9	10 X 9	10 X 9	10 X 9
No. of Speeds	4	2	5	5	5	5
Horsepower - RPM	1/3 - 1,075	1/3 - 1,080	3/4 - 1,075	3/4 - 1,075	1 - 1,075	1 - 1,075
Evaporator Coil						
Face Area (ft ²)	4.5	4.5	6.2	6.2	6.2	6.2
Rows Deep/ Fins per Inch	4 / 14	4 / 14	4 / 14	4 / 14	4 / 14	4 / 14
Drain Size (NPT)	3/4"	3/4"	3/4"	3/4"	3/4"	3/4"
Refrigerant Charge (oz)	165	165	192	192	195	195
Condenser Fan / Coil						
Horsepower - RPM	1/4 - 1,075	1/4 - 1,050	1/3 - 1,075	1/3 - 1,075	1/3 - 1,075	1/3 - 1,075
Fan Diameter / # Fan Blades	22" / 3	22" / 3	22" / 4	22" / 4	22" / 4	22" / 4
Face Area (ft ²)	17.2	17.2	21.2	21.2	21.2	21.2
Rows Deep/Fins per Inch	2 / 16	2 / 16	2 / 16	2 / 16	2 / 16	2 / 16
Electrical Data						
Voltage/ Phase/ Hz	208-230/3/60	460/3/60	208-230/3/60	460/3/60	208-230/3/60	460/3/60
Compressor RLA/LRA	9.6 / 77	4.8 / 35	12.4 / 88	6.4 / 44	17.3 / 123	6.7 / 49.5
Indoor Blower FLA / LRA	1.9 / 3.5	1.2 / 1.48	6 / -	6 / -	7.6 / -	7.6 / -
Outdoor Fan FLA / LRA	1.5 / 3.0	0.8 / 1.6	2.4 / 5.2	1.2 / 2.6	2.4 / 5.2	1.2 / 2.6
Total Unit Amps	10.5	5.5	15.5	8	19.7	9
Min. Circuit Ampacity ¹	15.4	8	23.8	15	31.7	17.2
Max. Overcurrent Protection ²	20 amps	10 amps	30 amps	20 amps	40 amps	20 amps
Ship/ Operating Weight (lbs)	438/ 416	438/ 416	492	492/ 469	523	523/ 500

¹ Wire size should be determined in accordance with National Electrical Codes. Extensive wire runs will require larger wire sizes.

² Must use time-delay fuses or HACR-type circuit breakers of the same size as noted.

EVAPORATOR BLOWER SPECIFICATIONS

Model	Speed	Volts	E.S.P (In. of H2O)								
				0.1	0.2	0.3	0.4	0.5	0.6	0.7	0.8
GPH13 36M23AA	Low	230	CFM	1,055	1,015	975	895	840	770	-	-
			Watts	315	310	300	285	270	255	-	-
	Med/Low	230	CFM	1,285	1,240	1,190	1,120	1,040	950	850	-
			Watts	385	375	365	350	335	315	295	-
	Med/High	230	CFM	1,470	1,425	1,345	1,285	1,195	1,085	980	865
			Watts	455	440	425	410	385	370	350	325
High	230	CFM	1,565	1,510	1,415	1,340	1,260	1,135	1,035	885	
		Watts	495	480	460	445	425	405	385	355	
GPH13 36M24AA	Low	460	CFM	1457	1385	1314	1240	1153	1047	-	-
			Watts	471	461	451	438	426	412	-	-
	High	460	CFM	1556	1502	1415	1343	1259	1163	-	-
			Watts	527	514	504	491	476	461	-	-
GPH13 48M23AA	T1	230	CFM	1,440	1,395	1,360	1,310	1,265	1,235	1,190	1,130
			Watts	275	285	295	315	325	335	345	355
	T2 / T3	230	CFM	1,795	1,765	1,715	1,695	1,650	1,600	1,500	1,375
			Watts	475	490	505	520	530	535	510	475
	T4 / T5	230	CFM	1,860	1,820	1,785	1,745	1,700	1,625	1,515	1,395
			Watts	515	530	545	565	570	550	535	485
GPH13 48M24AA	T1	460	CFM	1,440	1,395	1,360	1,310	1,265	1,235	1,190	1,130
			Watts	275	285	295	315	325	335	345	355
	T2 / T3	460	CFM	1,795	1,765	1,715	1,695	1,650	1,600	1,500	1,375
			Watts	475	490	505	520	530	535	510	475
	T4 / T5	460	CFM	1,860	1,820	1,785	1,745	1,700	1,625	1,515	1,395
			Watts	515	530	545	565	570	550	535	485
GPH13 60M23AA	T1	230	CFM	1,755	1,720	1,685	1,645	1,615	1,570	1,530	1,465
			Watts	420	435	455	460	475	490	500	500
	T2 / T3	230	CFM	1,850	1,820	1,775	1,735	1,705	1,675	1,610	1,495
			Watts	480	500	515	525	535	555	545	520
	T4 / T5	230	CFM	2,180	2,125	2,050	1,975	1,875	1,800	1,655	1,530
			Watts	770	755	725	700	675	640	575	540
GPH13 60M24AA	T1	460	CFM	1,755	1,720	1,685	1,645	1,615	1,570	1,530	1,465
			Watts	420	435	455	460	475	490	500	500
	T2 / T3	460	CFM	1,850	1,820	1,775	1,735	1,705	1,675	1,610	1,495
			Watts	480	500	515	525	535	555	545	520
	T4 / T5	460	CFM	2,180	2,125	2,050	1,975	1,875	1,800	1,655	1,530
			Watts	770	755	725	700	675	640	575	540

Notes

- Data shown is dry coil. Wet coil pressure drop is approximately 0.1" H2O, for two-row indoor coil; 0.2" H2O, for three-row indoor coil; and 0.3" H2O, for four-row indoor coil.
- Data shown does not include filter pressure drop, approx. 0.08" H2O.
- ALL MODELS SHOULD RUN NO LESS THAN 350 CFM/TON. USE HIGHER SPEED TAP OR NEXT SIZE LARGER BLOWER ASM. See Repair Parts list.
- Reduce airflow by 2% for 208-volt operation.

EVAPORATOR BLOWER SPECIFICATIONS (CONT.)

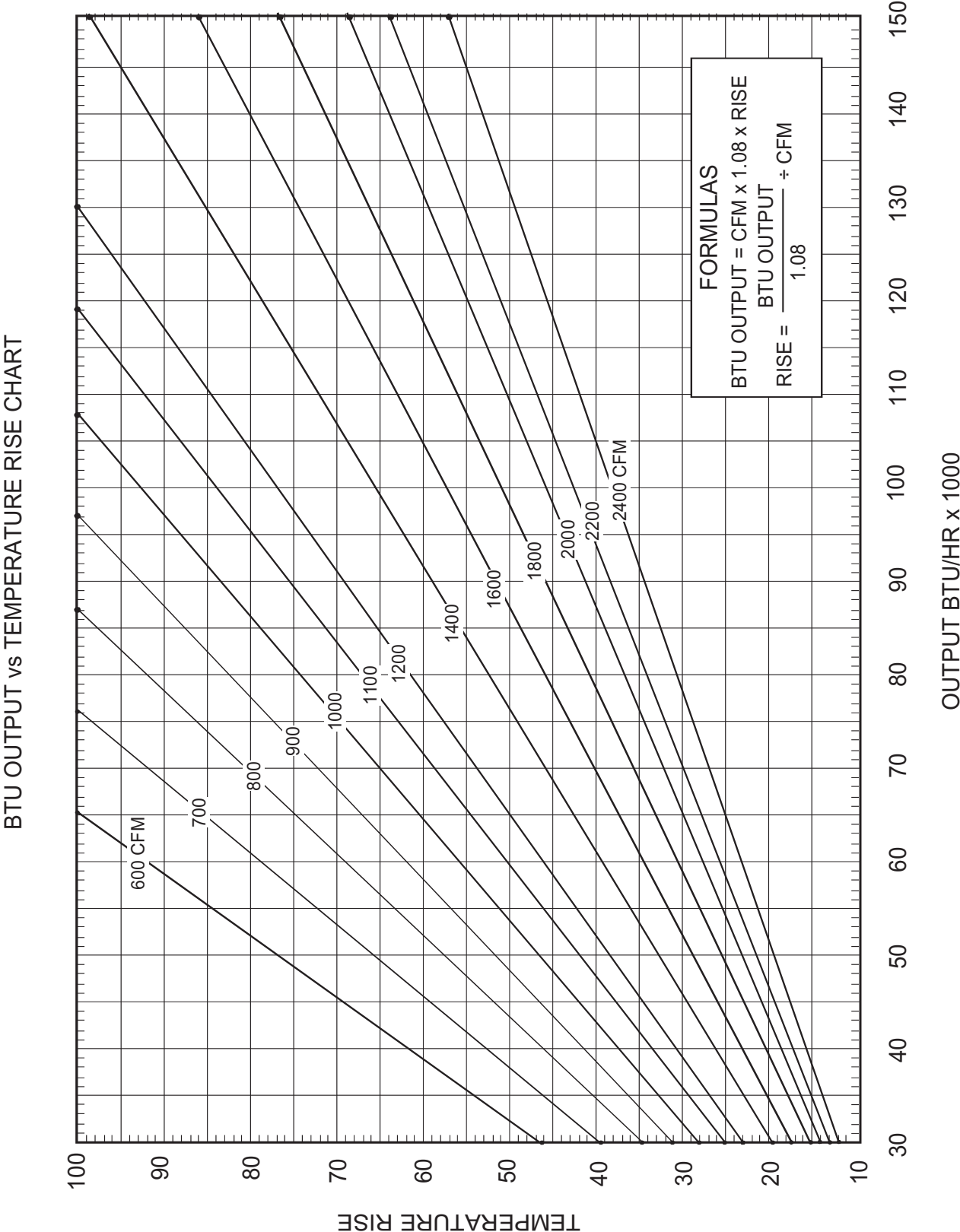

EXPANDED COOLING DATA — GPH1336M23AA

IDB	Airflow	Outdoor Ambient Temperature																							
		65°F				75°F				85°F				95°F				105°F				115°F			
		59	63	67	71	59	63	67	71	59	63	67	71	59	63	67	71	59	63	67	71	59	63	67	71
1350	MBh	34.7	36.0	39.4	-	33.9	35.1	38.5	-	33.1	34.3	37.6	-	32.3	33.4	36.6	-	30.7	31.8	34.8	-	28.4	29.4	32.2	-
	S/T	1.00	1.00	1.00	-	1.00	1.00	1.00	-	1.00	1.00	1.00	-	1.00	1.00	1.00	-	1.00	1.00	1.00	-	1.00	1.00	1.00	-
	ΔT	24	24	27	-	23	24	26	-	23	23	26	-	22	23	25	-	21	22	24	-	19	20	22	-
	kW	2.51	2.55	2.63	-	2.68	2.73	2.81	-	2.83	2.88	2.97	-	2.96	3.02	3.11	-	3.07	3.13	3.23	-	3.17	3.23	3.33	-
	Amps	8.4	8.6	8.8	-	8.9	9.1	9.3	-	9.5	9.6	9.9	-	10.0	10.2	10.4	-	10.5	10.7	10.9	-	11.0	11.2	11.5	-
	Hi PR	150	162	171	-	169	182	192	-	192	207	218	-	219	235	248	-	246	265	279	-	272	292	309	-
	Lo PR	46	49	54	-	49	52	57	-	51	54	59	-	53	57	62	-	56	60	65	-	58	62	67	-
	MBh	33.7	34.9	38.2	-	32.9	34.1	37.4	-	32.1	33.3	36.5	-	31.3	32.5	35.6	-	29.8	30.8	33.8	-	27.6	28.6	31.3	-
	S/T	1.00	1.00	1.00	-	1.00	1.00	1.00	-	1.00	1.00	1.00	-	1.00	1.00	1.00	-	1.00	1.00	1.00	-	1.00	1.00	1.00	-
	ΔT	26	27	29	-	25	26	29	-	25	25	28	-	24	25	27	-	23	24	26	-	21	22	24	-
70	kW	2.49	2.54	2.61	-	2.66	2.71	2.79	-	2.81	2.86	2.95	-	2.94	3.00	3.09	-	3.05	3.11	3.20	-	3.15	3.21	3.31	-
	Amps	8.4	8.5	8.7	-	8.8	9.0	9.2	-	9.4	9.6	9.8	-	9.9	10.1	10.3	-	10.4	10.6	10.9	-	10.9	11.1	11.4	-
	Hi PR	149	160	169	-	167	180	190	-	190	205	216	-	216	233	246	-	244	262	277	-	269	290	306	-
	Lo PR	46	49	53	-	48	52	56	-	50	54	58	-	53	56	61	-	55	59	64	-	57	61	67	-
	MBh	31.1	32.2	35.3	-	30.4	31.5	34.5	-	29.6	30.7	33.7	-	28.9	30.0	32.8	-	27.5	28.5	31.2	-	25.4	26.4	28.9	-
	S/T	1.00	1.00	1.00	-	1.00	1.00	1.00	-	1.00	1.00	1.00	-	1.00	1.00	1.00	-	1.00	1.00	1.00	-	1.00	1.00	1.00	-
	ΔT	27	28	31	-	27	28	30	-	26	27	29	-	25	26	29	-	24	25	27	-	22	23	25	-
	kW	2.44	2.48	2.55	-	2.60	2.65	2.73	-	2.75	2.80	2.88	-	2.87	2.93	3.02	-	2.98	3.04	3.13	-	3.07	3.14	3.23	-
	Amps	8.2	8.3	8.5	-	8.7	8.8	9.0	-	9.2	9.4	9.6	-	9.7	9.9	10.1	-	10.2	10.4	10.6	-	10.6	10.8	11.1	-
	Hi PR	144	155	164	-	162	174	184	-	184	198	209	-	210	226	239	-	236	254	268	-	261	281	297	-
Lo PR	44	47	52	-	47	50	55	-	49	52	57	-	51	55	60	-	54	57	62	-	56	59	65	-	

1350	MBh	35.3	36.3	39.3	42.2	34.5	35.5	38.4	41.2	33.6	34.6	37.5	40.2	32.8	33.8	36.6	39.3	31.2	32.1	34.7	37.3	28.9	29.7	32.2	34.5
	S/T	1.00	1.00	1.00	1.00	1.00	1.00	1.00	1.00	1.00	1.00	1.00	1.00	1.00	1.00	1.00	1.00	1.00	1.00	1.00	1.00	1.00	1.00	1.00	1.00
	ΔT	24	25	27	29	23	24	26	28	23	24	26	27	22	23	25	27	21	22	24	25	20	20	22	24
	kW	2.53	2.57	2.64	2.72	2.70	2.75	2.83	2.91	2.85	2.90	2.99	3.08	2.98	3.04	3.13	3.23	3.10	3.16	3.25	3.35	3.19	3.26	3.36	3.46
	Amps	8.5	8.6	8.8	9.1	9.0	9.1	9.4	9.6	9.5	9.7	10.0	10.3	10.0	10.2	10.5	10.8	10.5	10.7	11.0	11.4	11.0	11.3	11.6	11.9
	Hi PR	152	164	173	180	171	183	194	202	194	209	220	230	221	238	251	262	248	267	282	294	275	295	312	325
	Lo PR	47	50	54	58	49	53	57	61	51	55	60	64	54	57	63	67	57	60	66	70	59	62	68	72
	MBh	34.2	35.3	38.2	41.0	33.5	34.4	37.3	40.0	32.7	33.6	36.4	39.1	31.9	32.8	35.5	38.1	30.3	31.2	33.7	36.2	28.0	28.9	31.2	33.5
	S/T	1.00	1.00	1.00	1.00	1.00	1.00	1.00	1.00	1.00	1.00	1.00	1.00	1.00	1.00	1.00	1.00	1.00	1.00	1.00	1.00	1.00	1.00	1.00	1.00
	ΔT	26	27	29	31	26	26	29	31	25	26	28	30	24	25	27	29	23	24	26	28	21	22	24	26
75	kW	2.51	2.55	2.63	2.70	2.68	2.73	2.81	2.89	2.83	2.88	2.97	3.06	2.96	3.02	3.11	3.20	3.07	3.14	3.23	3.33	3.17	3.24	3.33	3.44
	Amps	8.4	8.6	8.8	9.0	8.9	9.1	9.3	9.5	9.5	9.7	9.9	10.2	10.0	10.2	10.4	10.7	10.5	10.7	11.0	11.3	11.0	11.2	11.5	11.8
	Hi PR	150	162	171	178	169	182	192	200	192	207	218	228	219	235	248	259	246	265	280	292	272	293	309	322
	Lo PR	46	49	54	57	49	52	57	61	51	54	59	63	53	57	62	66	56	60	65	69	58	62	67	72
	MBh	31.6	32.5	35.2	37.8	30.9	31.8	34.4	36.9	30.1	31.0	33.6	36.1	29.4	30.3	32.8	35.2	27.9	28.8	31.1	33.4	25.9	26.6	28.8	31.0
	S/T	1.00	1.00	1.00	1.00	1.00	1.00	1.00	1.00	1.00	1.00	1.00	1.00	1.00	1.00	1.00	1.00	1.00	1.00	1.00	1.00	1.00	1.00	1.00	1.00
	ΔT	28	28	31	33	27	28	30	32	26	27	29	32	26	27	29	31	24	25	27	29	23	23	25	27
	kW	2.45	2.50	2.57	2.64	2.62	2.67	2.75	2.83	2.77	2.82	2.90	2.99	2.89	2.95	3.04	3.13	3.00	3.06	3.16	3.25	3.10	3.16	3.26	3.36
	Amps	8.2	8.4	8.6	8.8	8.7	8.9	9.1	9.3	9.3	9.4	9.7	10.0	9.8	9.9	10.2	10.5	10.2	10.4	10.7	11.0	10.7	10.9	11.2	11.6
	Hi PR	146	157	166	173	164	176	186	194	186	200	212	221	212	228	241	251	239	257	271	283	264	284	300	312
Lo PR	45	48	52	56	47	51	55	59	49	53	57	61	52	55	60	64	54	58	63	67	56	60	65	70	

Shaded area reflects ACCA (TVA) conditions IDB: Entering Indoor Dry Bulb Temperature kW = Total system power Amps = outdoor unit amps (comp. +fan)
 High and low pressures are measured at the liquid and suction service valves.

EXPANDED COOLING DATA — GPH1336M23AA (CONT.)

IDB	Airflow	Outdoor Ambient Temperature																								
		65°F				75°F				85°F				95°F				105°F				115°F				
		59	63	67	71	59	63	67	71	59	63	67	71	59	63	67	71	59	63	67	71	59	63	67	71	
80	1350	MBh	35.9	36.7	39.2	41.9	35.1	35.8	38.3	40.9	34.2	35.0	37.4	40.0	33.4	34.1	36.5	39.0	31.7	32.4	34.6	37.0	29.4	30.0	32.1	34.3
		S/T	1.00	1.00	1.00	1.00	1.00	1.00	1.00	1.00	1.00	1.00	1.00	1.00	1.00	1.00	1.00	1.00	1.00	1.00	1.00	1.00	1.00	1.00	1.00	1.00
	ΔT	24	25	27	29	24	24	26	28	23	24	25	27	23	23	25	27	22	22	24	25	20	20	22	23	
	kW	2.54	2.59	2.66	2.74	2.72	2.77	2.85	2.93	2.87	2.93	3.01	3.10	3.01	3.07	3.16	3.25	3.12	3.18	3.28	3.38	3.22	3.29	3.39	3.49	
	Amps	8.5	8.7	8.9	9.1	9.0	9.2	9.4	9.7	9.6	9.8	10.0	10.3	10.1	10.3	10.6	10.9	10.6	10.8	11.1	11.5	11.1	11.3	11.6	12.0	
	Hi PR	153	165	174	182	172	185	196	204	196	211	223	232	223	240	254	264	251	270	285	297	277	298	315	329	
	Lo PR	47	50	55	58	50	53	58	62	52	55	60	64	55	58	63	67	57	61	66	71	59	63	69	73	
	MBh	34.9	35.6	38.1	40.7	34.0	34.8	37.2	39.7	33.2	34.0	36.3	38.8	32.4	33.1	35.4	37.8	30.8	31.5	33.6	36.0	28.5	29.2	31.2	33.3	
	S/T	1.00	1.00	1.00	1.00	1.00	1.00	1.00	1.00	1.00	1.00	1.00	1.00	1.00	1.00	1.00	1.00	1.00	1.00	1.00	1.00	1.00	1.00	1.00	1.00	
	ΔT	27	27	29	31	26	27	28	30	25	26	28	30	25	25	27	29	24	24	26	28	22	22	24	26	
kW	2.53	2.57	2.64	2.72	2.70	2.75	2.83	2.91	2.85	2.90	2.99	3.08	2.98	3.04	3.13	3.23	3.10	3.16	3.25	3.35	3.19	3.26	3.36	3.46		
Amps	8.5	8.6	8.8	9.1	9.0	9.1	9.4	9.6	9.5	9.7	10.0	10.3	10.0	10.2	10.5	10.8	10.5	10.7	11.0	11.4	11.0	11.3	11.6	11.9		
Hi PR	152	164	173	180	171	184	194	202	194	209	220	230	221	238	251	262	248	267	282	295	275	295	312	325		
Lo PR	47	50	54	58	49	53	57	61	51	55	60	64	54	57	63	67	57	60	66	70	59	62	68	72		
MBh	32.2	32.9	35.1	37.5	31.4	32.1	34.3	36.7	30.7	31.3	33.5	35.8	29.9	30.6	32.7	34.9	28.4	29.1	31.0	33.2	26.3	26.9	28.8	30.7		
S/T	1.00	1.00	1.00	1.00	1.00	1.00	1.00	1.00	1.00	1.00	1.00	1.00	1.00	1.00	1.00	1.00	1.00	1.00	1.00	1.00	1.00	1.00	1.00	1.00		
ΔT	28	29	31	33	28	28	30	32	27	27	29	31	26	27	29	31	25	25	27	29	23	24	25	27		
kW	2.47	2.52	2.59	2.66	2.64	2.69	2.77	2.85	2.79	2.84	2.92	3.01	2.92	2.97	3.06	3.15	3.03	3.09	3.18	3.28	3.12	3.18	3.28	3.38		
Amps	8.3	8.4	8.6	8.9	8.8	8.9	9.2	9.4	9.3	9.5	9.8	10.0	9.8	10.0	10.3	10.6	10.3	10.5	10.8	11.1	10.8	11.0	11.3	11.6		
Hi PR	147	159	168	175	165	178	188	196	188	202	214	223	214	231	243	254	241	259	274	286	266	287	303	316		
Lo PR	45	48	53	56	48	51	56	59	50	53	58	62	52	56	61	65	55	58	64	68	57	60	66	70		
85	1350	MBh	36.5	37.2	39.0	41.6	35.7	36.4	38.1	40.6	34.8	35.5	37.2	39.7	34.0	34.6	36.3	38.7	32.3	32.9	34.5	36.8	29.9	30.5	31.9	34.1
		S/T	1.00	1.00	1.00	1.00	1.00	1.00	1.00	1.00	1.00	1.00	1.00	1.00	1.00	1.00	1.00	1.00	1.00	1.00	1.00	1.00	1.00	1.00	1.00	1.00
	ΔT	25	25	27	28	24	25	26	28	24	24	25	27	23	24	25	26	22	22	23	25	20	21	22	23	
	kW	2.56	2.61	2.68	2.76	2.74	2.79	2.87	2.95	2.89	2.95	3.04	3.13	3.03	3.09	3.18	3.28	3.14	3.21	3.30	3.41	3.24	3.31	3.41	3.52	
	Amps	8.6	8.7	8.9	9.2	9.1	9.3	9.5	9.8	9.7	9.9	10.1	10.4	10.2	10.4	10.7	11.0	10.7	10.9	11.2	11.5	11.2	11.4	11.7	12.1	
	Hi PR	155	167	176	184	174	187	198	206	198	213	225	234	223	240	254	264	251	270	285	297	277	298	315	329	
	Lo PR	48	51	55	59	50	54	59	62	52	56	61	65	55	59	64	68	58	61	67	71	60	64	69	74	
	MBh	35.5	36.2	37.9	40.4	34.6	35.3	37.0	39.5	33.8	34.5	36.1	38.5	33.0	33.6	35.2	37.6	31.3	31.9	33.5	35.7	29.0	29.6	31.0	33.1	
	S/T	1.00	1.00	1.00	1.00	1.00	1.00	1.00	1.00	1.00	1.00	1.00	1.00	1.00	1.00	1.00	1.00	1.00	1.00	1.00	1.00	1.00	1.00	1.00	1.00	
	ΔT	27	28	29	31	27	27	28	30	26	26	28	30	25	26	27	29	24	24	26	27	22	23	24	25	
kW	2.54	2.59	2.66	2.74	2.72	2.77	2.85	2.93	2.87	2.93	3.01	3.10	3.01	3.07	3.16	3.25	3.12	3.18	3.28	3.38	3.22	3.29	3.39	3.49		
Amps	8.5	8.7	8.9	9.1	9.0	9.2	9.4	9.7	9.6	9.8	10.0	10.3	10.1	10.3	10.6	10.9	10.6	10.8	11.1	11.5	11.1	11.3	11.6	12.0		
Hi PR	153	165	174	182	172	185	196	204	196	211	223	232	223	240	254	264	251	270	285	297	277	298	315	329		
Lo PR	47	50	55	58	50	53	58	62	52	55	60	64	55	58	63	67	57	61	66	71	59	63	69	73		
MBh	32.7	33.4	34.9	37.3	32.0	32.6	34.1	36.4	31.2	31.8	33.3	35.6	30.5	31.0	32.5	34.7	28.9	29.5	30.9	33.0	26.8	27.3	28.6	30.5		
S/T	1.00	1.00	1.00	1.00	1.00	1.00	1.00	1.00	1.00	1.00	1.00	1.00	1.00	1.00	1.00	1.00	1.00	1.00	1.00	1.00	1.00	1.00	1.00	1.00		
ΔT	29	29	31	33	28	29	30	32	27	28	29	31	27	27	28	30	25	26	27	29	23	24	25	27		
kW	2.49	2.54	2.61	2.68	2.66	2.71	2.79	2.87	2.81	2.86	2.94	3.03	2.94	3.00	3.08	3.18	3.05	3.11	3.20	3.30	3.15	3.21	3.31	3.41		
Amps	8.3	8.5	8.7	8.9	8.8	9.0	9.2	9.5	9.4	9.6	9.8	10.1	9.9	10.1	10.3	10.7	10.4	10.6	10.9	11.2	10.9	11.1	11.4	11.7		
Hi PR	149	160	169	176	167	180	190	198	190	204	216	225	216	233	246	256	243	262	277	289	269	289	306	319		
Lo PR	46	49	53	57	48	52	56	60	50	54	58	62	53	56	61	65	55	59	64	69	57	61	67	71		

Shaded area reflects ARI conditions IDB: Entering Indoor Dry Bulb Temperature kW = Total system power Amps = outdoor unit amps (comp. +fan)
 High and low pressures are measured at the liquid and suction service valves.

EXPANDED COOLING DATA — GPH1336M24AA

IDB	Airflow	Outdoor Ambient Temperature																								
		65°F				75°F				85°F				95°F				105°F				115°F				
		59	63	67	71	59	63	67	71	59	63	67	71	59	63	67	71	59	63	67	71	59	63	67	71	
70	1350	MBh	34.9	36.2	39.6	-	34.1	35.3	38.7	-	33.3	34.5	37.8	-	32.5	33.6	36.9	-	30.8	32.0	35.0	-	28.6	29.6	32.4	-
		S/T	1.00	1.00	1.00	-	1.00	1.00	1.00	-	1.00	1.00	1.00	-	1.00	1.00	1.00	-	1.00	1.00	1.00	-	1.00	1.00	1.00	-
		ΔT	24	25	27	-	23	24	26	-	23	23	26	-	22	23	25	-	21	22	24	-	19	20	22	-
		kW	2.49	2.54	2.62	-	2.67	2.73	2.81	-	2.83	2.89	2.98	-	2.97	3.03	3.12	-	3.09	3.15	3.25	-	3.19	3.26	3.36	-
		Amps	4.4	4.5	4.6	-	4.7	4.7	4.9	-	5.0	5.1	5.2	-	5.2	5.3	5.5	-	5.5	5.6	5.7	-	5.7	5.9	6.0	-
	1200	Hi PR	149	161	170	-	167	180	190	-	190	205	216	-	217	233	246	-	244	263	277	-	270	290	306	-
		Lo PR	63	68	74	-	67	71	78	-	70	74	81	-	73	78	85	-	77	82	89	-	79	84	92	-
		MBh	33.9	35.1	38.5	-	33.1	34.3	37.6	-	32.3	33.5	36.7	-	31.5	32.7	35.8	-	29.9	31.0	34.0	-	27.7	28.7	31.5	-
		S/T	1.00	1.00	1.00	-	1.00	1.00	1.00	-	1.00	1.00	1.00	-	1.00	1.00	1.00	-	1.00	1.00	1.00	-	1.00	1.00	1.00	-
		ΔT	26	27	29	-	25	26	29	-	25	26	28	-	24	25	27	-	23	24	26	-	21	22	24	-
1050	kW	2.42	2.47	2.54	-	2.59	2.64	2.72	-	2.74	2.80	2.88	-	2.88	2.94	3.03	-	2.99	3.05	3.15	-	3.09	3.15	3.25	-	
	Amps	4.3	4.4	4.5	-	4.5	4.6	4.7	-	4.8	4.9	5.0	-	5.1	5.2	5.3	-	5.3	5.4	5.6	-	5.6	5.7	5.8	-	
	Hi PR	143	154	163	-	161	173	183	-	183	197	208	-	208	224	237	-	234	252	266	-	259	279	294	-	
	Lo PR	61	65	71	-	64	69	75	-	67	71	78	-	70	75	82	-	74	78	86	-	76	81	89	-	
	MBh	31.3	32.4	35.5	-	30.5	31.6	34.7	-	29.8	30.9	33.8	-	29.1	30.1	33.0	-	27.6	28.6	31.4	-	25.6	26.5	29.1	-	

75	1350	MBh	35.48	36.53	39.54	42.43	34.65	35.68	38.62	41.45	33.83	34.83	37.70	40.46	33.00	33.98	36.78	39.47	31.35	32.28	34.94	37.50	29.04	29.90	32.36	34.74
		S/T	1.00	1.00	1.00	1.00	1.00	1.00	1.00	1.00	1.00	1.00	1.00	1.00	1.00	1.00	1.00	1.00	1.00	1.00	1.00	1.00	1.00	1.00	1.00	1.00
		ΔT	24	25	27	29	24	24	26	28	23	24	26	28	22	23	25	27	21	22	24	26	20	20	22	24
		kW	2.51	2.56	2.64	2.72	2.69	2.75	2.83	2.92	2.85	2.91	3.00	3.09	2.99	3.05	3.15	3.25	3.11	3.18	3.28	3.38	3.21	3.28	3.39	3.50
		Amps	4.4	4.5	4.6	4.7	4.7	4.8	4.9	5.0	5.0	5.1	5.2	5.4	5.3	5.4	5.5	5.7	5.5	5.6	5.8	6.0	5.8	5.9	6.1	6.2
	1200	Hi PR	151	162	171	179	169	182	192	200	192	207	219	228	219	236	249	260	246	265	280	292	272	293	309	323
		Lo PR	64	68	74	79	68	72	79	84	70	75	82	87	74	79	86	91	78	82	90	96	80	85	93	99
		MBh	34.4	35.5	38.4	41.2	33.6	34.6	37.5	40.2	32.8	33.8	36.6	39.3	32.0	33.0	35.7	38.3	30.4	31.3	33.9	36.4	28.2	29.0	31.4	33.7
		S/T	1.00	1.00	1.00	1.00	1.00	1.00	1.00	1.00	1.00	1.00	1.00	1.00	1.00	1.00	1.00	1.00	1.00	1.00	1.00	1.00	1.00	1.00	1.00	1.00
		ΔT	26	27	29	32	26	27	29	31	25	26	28	30	25	25	27	29	23	24	26	28	22	22	24	26
1050	kW	2.49	2.54	2.62	2.70	2.67	2.73	2.81	2.89	2.83	2.89	2.98	3.07	2.97	3.03	3.13	3.22	3.09	3.15	3.25	3.36	3.19	3.26	3.36	3.47	
	Amps	4.4	4.5	4.6	4.7	4.7	4.7	4.9	5.0	5.0	5.1	5.2	5.3	5.2	5.3	5.5	5.6	5.5	5.6	5.7	5.9	5.7	5.9	6.0	6.2	
	Hi PR	149	161	170	177	167	180	190	198	190	205	216	226	217	233	247	257	244	263	277	289	270	290	306	320	
	Lo PR	63	68	74	79	67	71	78	83	70	74	81	86	73	78	85	91	77	82	89	95	79	84	92	98	
	MBh	31.8	32.7	35.4	38.0	31.1	32.0	34.6	37.1	30.3	31.2	33.8	36.3	29.6	30.4	33.0	35.4	28.1	28.9	31.3	33.6	26.0	26.8	29.0	31.1	
1050	S/T	1.00	1.00	1.00	1.00	1.00	1.00	1.00	1.00	1.00	1.00	1.00	1.00	1.00	1.00	1.00	1.00	1.00	1.00	1.00	1.00	1.00	1.00	1.00	1.00	
	ΔT	28	29	31	33	27	28	30	33	27	27	30	32	26	27	29	31	25	25	27	29	23	23	25	27	
	kW	2.44	2.49	2.56	2.63	2.61	2.66	2.74	2.83	2.76	2.82	2.91	3.00	2.90	2.96	3.05	3.15	3.01	3.08	3.17	3.27	3.11	3.18	3.28	3.38	
	Amps	4.3	4.4	4.5	4.6	4.6	4.6	4.8	4.9	4.9	4.9	5.1	5.2	5.1	5.2	5.3	5.5	5.4	5.5	5.6	5.8	5.6	5.7	5.9	6.1	
	Hi PR	145	156	165	172	162	175	185	193	185	199	210	219	210	226	239	249	237	255	269	281	262	281	297	310	
Lo PR	62	66	72	76	65	69	76	80	68	72	79	84	71	76	82	88	74	79	86	92	77	82	89	95		

Shaded area reflects ACCA (TVA) conditions IDB: Entering Indoor Dry Bulb Temperature kW = Total system power Amps = outdoor unit amps (comp. +fan)
 High and low pressures are measured at the liquid and suction service valves.

EXPANDED COOLING DATA — GPH1336M24AA (CONT.)

IDB	Airflow	Outdoor Ambient Temperature																							
		65°F				75°F				85°F				95°F				105°F				115°F			
		59	63	67	71	59	63	67	71	59	63	67	71	59	63	67	71	59	63	67	71	59	63	67	71
	MBh	36.1	36.9	39.4	42.1	35.3	36	38.5	41.2	34.4	35.2	37.6	40.2	33.6	34.32	36.67	39.2	31.9	32.6	34.8	37.2	29.6	30.2	32.3	34.5
	S/T	1	1	1	1	1	1	1	1	1	1	1	1	1	1	1	1	1	1	1	1	1	1	1	1
	ΔT	25	25	27	29	24	25	26	28	23	24	26	27	23	23	25	27	22	22	24	25	20	21	22	23
1350	kW	2.53	2.58	2.66	2.74	2.71	2.77	2.85	2.92	2.87	2.93	3.02	3.12	3.02	3.079	3.175	3.28	3.14	3.2	3.3	3.41	3.24	3.31	3.41	3.53
	Amps	4.46	4.54	4.65	4.78	4.72	4.81	4.93	5.07	5.03	5.13	5.26	5.41	5.3	5.399	5.54	5.71	5.56	5.67	5.82	6	5.83	5.94	6.1	6.29
	Hi PR	152	164	173	180	171	184	194	202	194	209	221	230	221	238.2	251.5	262	249	268	283	295	275	296	313	326
	Lo PR	64.8	68.9	75.2	80.1	68.4	72.8	79.5	84.6	71.1	75.7	82.6	88	74.7	79.47	86.76	92.4	78.3	83.3	90.9	96.8	81	86.1	94	100
	MBh	35.1	35.8	38.3	40.9	34.2	35	37.4	40	33.4	34.2	36.5	39	32.6	33.32	35.6	38.1	31	31.7	33.8	36.2	28.7	29.3	31.3	33.5
	S/T	1	1	1	1	1	1	1	1	1	1	1	1	1	1	1	1	1	1	1	1	1	1	1	1
	ΔT	27	27	29	31	26	27	29	31	26	26	28	30	25	26	27	29	24	24	26	28	22	22	24	26
80	kW	2.51	2.56	2.64	2.72	2.69	2.75	2.83	2.92	2.85	2.91	3	3.09	2.99	3.055	3.15	3.25	3.11	3.18	3.28	3.38	3.22	3.28	3.39	3.5
	Amps	4.43	4.51	4.62	4.74	4.69	4.78	4.9	5.04	5	5.09	5.22	5.37	5.26	5.36	5.5	5.66	5.52	5.63	5.78	5.96	5.78	5.9	6.06	6.24
	Hi PR	151	162	171	179	169	182	192	200	192	207	219	228	219	235.8	249	260	247	265	280	292	272	293	310	323
	Lo PR	64.1	68.2	74.5	79.3	67.7	72.1	78.7	83.8	70.4	74.9	81.8	87.1	74	78.68	85.9	91.5	77.5	82.5	90	95.9	80.2	85.3	93.1	99.2
	MBh	32.4	33.1	35.3	37.8	31.6	32.3	34.5	36.9	30.9	31.5	33.7	36	30.1	30.76	32.86	35.1	28.6	29.2	31.2	33.4	26.5	27.1	28.9	30.9
	S/T	1	1	1	1	1	1	1	1	1	1	1	1	1	1	1	1	1	1	1	1	1	1	1	1
	ΔT	28	29	31	33	28	28	30	32	27	28	29	32	26	27	29	31	25	26	27	29	23	24	25	27
1050	kW	2.46	2.5	2.58	2.65	2.63	2.68	2.76	2.85	2.79	2.84	2.93	3.02	2.92	2.983	3.075	3.17	3.04	3.1	3.2	3.3	3.14	3.2	3.31	3.41
	Amps	4.34	4.42	4.52	4.65	4.6	4.68	4.79	4.93	4.89	4.98	5.11	5.26	5.15	5.244	5.38	5.54	5.4	5.51	5.65	5.82	5.65	5.76	5.92	6.1
	Hi PR	146	157	166	173	164	177	186	194	187	201	212	221	213	228.7	241.5	252	239	257	272	283	264	284	300	313
	Lo PR	62.2	66.2	72.2	76.9	65.7	69.9	76.3	81.3	68.3	72.7	79.3	84.5	71.7	76.32	83.32	88.7	75.2	80	87.3	93	77.8	82.7	90.3	96.2

	MBh	36.7	37.4	39.2	41.8	35.9	36.6	38.3	40.9	35	35.7	37.4	39.9	34.2	34.84	36.48	38.9	32.5	33.1	34.7	37	30.1	30.7	32.1	34.3
	S/T	1	1	1	1	1	1	1	1	1	1	1	1	1	1	1	1	1	1	1	1	1	1	1	1
	ΔT	25	26	27	28	24	25	26	28	24	24	25	27	23	24	25	27	22	23	24	25	20	21	22	23
1350	kW	2.55	2.6	2.68	2.76	2.73	2.79	2.87	2.96	2.9	2.96	3.05	3.14	3.04	3.103	3.2	3.3	3.16	3.23	3.33	3.44	3.27	3.34	3.44	3.55
	Amps	4.49	4.57	4.68	4.81	4.76	4.84	4.96	5.11	5.07	5.16	5.29	5.45	5.34	5.438	5.58	5.75	5.6	5.71	5.87	6.05	5.87	5.98	6.15	6.34
	Hi PR	154	165	175	182	173	186	196	205	196	211	223	233	224	240.5	254	265	251	271	286	298	278	299	316	329
	Lo PR	65.4	69.6	76	80.9	69.1	73.5	80.3	85.5	71.8	76.4	83.4	88.8	75.4	80.27	87.63	93.3	79.1	84.1	91.8	97.8	81.8	87	95	101
	MBh	35.7	36.4	38.1	40.6	34.8	35.5	37.2	39.7	34	34.7	36.3	38.7	33.2	33.82	35.42	37.8	31.5	32.1	33.7	35.9	29.2	29.8	31.2	33.3
	S/T	1	1	1	1	1	1	1	1	1	1	1	1	1	1	1	1	1	1	1	1	1	1	1	1
	ΔT	27	28	29	31	27	27	28	30	26	27	28	30	25	26	27	29	24	25	26	28	22	23	24	25
1200	kW	2.53	2.58	2.66	2.74	2.71	2.77	2.85	2.94	2.87	2.93	3.02	3.12	3.02	3.079	3.175	3.28	3.14	3.2	3.3	3.41	3.24	3.31	3.41	3.53
	Amps	4.46	4.54	4.65	4.78	4.72	4.81	4.93	5.07	5.03	5.13	5.26	5.41	5.3	5.399	5.54	5.71	5.56	5.67	5.82	6	5.83	5.94	6.1	6.29
	Hi PR	152	164	173	180	171	184	194	202	194	209	221	230	221	238.2	251.5	262	249	268	283	295	275	296	313	326
	Lo PR	64.8	68.9	75.2	80.1	68.4	72.8	79.5	84.6	71.1	75.7	82.6	88	74.7	79.47	86.76	92.4	78.3	83.3	90.9	96.8	81	86.1	94	100
	MBh	32.9	33.6	35.1	37.5	32.2	32.8	34.3	36.6	31.4	32	33.5	35.8	30.6	31.22	32.69	34.9	29.1	29.7	31.1	33.1	26.9	27.5	28.8	30.7
	S/T	1	1	1	1	1	1	1	1	1	1	1	1	1	1	1	1	1	1	1	1	1	1	1	1
	ΔT	29	29	31	33	28	29	30	32	27	28	29	31	27	27	29	31	25	26	27	29	24	24	25	27
1050	kW	2.47	2.52	2.6	2.68	2.65	2.7	2.79	2.87	2.81	2.86	2.95	3.04	2.94	3.006	3.099	3.2	3.06	3.13	3.22	3.33	3.16	3.23	3.33	3.44
	Amps	4.37	4.45	4.55	4.68	4.63	4.71	4.83	4.96	4.93	5.02	5.14	5.29	5.18	5.282	5.419	5.58	5.44	5.55	5.69	5.87	5.7	5.81	5.96	6.15
	Hi PR	148	159	168	175	166	178	188	196	188	203	214	223	215	231.0	243.9	254	242	260	274	286	267	287	303	316
	Lo PR	62.8	66.8	73	77.7	66.4	70.6	77.1	82.1	69	73.4	80.1	85.3	72.5	77.09	84.16	89.6	75.9	80.8	88.2	93.9	78.5	83.6	91.2	97.2

Shaded area reflects ARI conditions IDB: Entering Indoor Dry Bulb Temperature kW = Total system power Amps = outdoor unit amps (comp. +fan)
 High and low pressures are measured at the liquid and suction service valves.

EXPANDED COOLING DATA — GPH1348M23AA

IDB	Airflow	Outdoor Ambient Temperature																								
		65°F				75°F				85°F				95°F				105°F				115°F				
		59	63	67	71	59	63	67	71	59	63	67	71	59	63	67	71	59	63	67	71	59	63	67	71	
70	1941	MBh	47.0	48.8	53.4	-	45.9	47.6	52.2	-	44.8	46.5	50.9	-	43.8	45.4	49.7	-	41.6	43.1	47.2	-	38.5	39.9	43.7	-
	S/T	1.00	1.00	1.00	-	1.00	1.00	1.00	-	1.00	1.00	1.00	-	1.00	1.00	1.00	-	1.00	1.00	1.00	-	1.00	1.00	1.00	-	
	ΔT	22	23	25	-	22	23	25	-	21	22	24	-	21	21	24	-	20	20	22	-	18	19	21	-	
	kW	3.41	3.48	3.57	-	3.64	3.71	3.81	-	3.84	3.91	4.03	-	4.02	4.10	4.21	-	4.17	4.25	4.37	-	4.30	4.38	4.51	-	
	Amps	12.8	13.0	13.3	-	13.4	13.7	13.9	-	14.2	14.4	14.7	-	14.8	15.1	15.4	-	15.5	15.7	16.1	-	16.1	16.4	16.7	-	
	Hi PR	149	160	169	-	167	179	190	-	190	204	216	-	216	232	245	-	243	262	276	-	269	289	305	-	
	Lo PR	63	68	74	-	67	71	78	-	70	74	81	-	73	78	85	-	77	82	89	-	79	84	92	-	
	1725	MBh	45.7	47.3	51.9	-	44.6	46.2	50.7	-	43.5	45.1	49.4	-	42.5	44.0	48.2	-	40.4	41.8	45.8	-	37.4	38.7	42.5	-
	S/T	1.00	1.00	1.00	-	1.00	1.00	1.00	-	1.00	1.00	1.00	-	1.00	1.00	1.00	-	1.00	1.00	1.00	-	1.00	1.00	1.00	-	
	ΔT	24	25	28	-	24	25	27	-	23	24	26	-	23	23	26	-	22	22	24	-	20	21	23	-	
kW	3.39	3.45	3.55	-	3.62	3.68	3.79	-	3.81	3.89	4.00	-	3.99	4.07	4.18	-	4.14	4.22	4.34	-	4.26	4.35	4.48	-		
Amps	12.7	12.9	13.2	-	13.4	13.6	13.9	-	14.1	14.3	14.6	-	14.7	15.0	15.3	-	15.4	15.6	16.0	-	16.0	16.3	16.6	-		
Hi PR	147	158	167	-	165	178	188	-	188	202	213	-	214	230	243	-	241	259	273	-	266	286	302	-		
Lo PR	63	67	73	-	66	71	77	-	69	73	80	-	72	77	84	-	76	81	88	-	79	84	91	-		
1509	MBh	42.1	43.7	47.9	-	41.2	42.7	46.8	-	40.2	41.7	45.6	-	39.2	40.6	44.5	-	37.2	38.6	42.3	-	34.5	35.8	39.2	-	
S/T	1.00	1.00	1.00	-	1.00	1.00	1.00	-	1.00	1.00	1.00	-	1.00	1.00	1.00	-	1.00	1.00	1.00	-	1.00	1.00	1.00	-		
ΔT	26	27	29	-	25	26	28	-	24	25	28	-	24	25	27	-	23	24	26	-	21	22	24	-		
kW	3.32	3.38	3.47	-	3.54	3.61	3.70	-	3.73	3.80	3.91	-	3.90	3.98	4.09	-	4.04	4.12	4.24	-	4.17	4.25	4.38	-		
Amps	12.5	12.7	13.0	-	13.1	13.3	13.6	-	13.8	14.1	14.4	-	14.5	14.7	15.0	-	15.1	15.3	15.7	-	15.7	15.9	16.3	-		
Hi PR	143	154	162	-	160	172	182	-	182	196	207	-	207	223	236	-	233	251	265	-	258	278	293	-		
Lo PR	61	65	71	-	64	69	75	-	67	71	78	-	70	75	82	-	74	78	86	-	76	81	89	-		
75	1941	MBh	47.8	49.2	53.3	57.2	46.7	48.1	52.1	55.9	45.6	47.0	50.8	54.6	44.5	45.8	49.6	53.2	42.3	43.5	47.1	50.6	39.2	40.3	43.6	46.8
	S/T	1.00	1.00	1.00	1.00	1.00	1.00	1.00	1.00	1.00	1.00	1.00	1.00	1.00	1.00	1.00	1.00	1.00	1.00	1.00	1.00	1.00	1.00	1.00	1.00	
	ΔT	23	23	25	27	22	23	25	26	22	22	24	26	21	22	23	25	20	21	22	24	19	19	21	22	
	kW	3.44	3.50	3.60	3.70	3.67	3.74	3.84	3.95	3.87	3.94	4.06	4.18	4.05	4.13	4.25	4.37	4.20	4.28	4.41	4.54	4.33	4.42	4.55	4.69	
	Amps	12.9	13.1	13.3	13.7	13.5	13.7	14.0	14.4	14.3	14.5	14.8	15.2	14.9	15.2	15.5	15.9	15.6	15.8	16.2	16.6	16.2	16.5	16.9	17.3	
	Hi PR	150	162	171	178	168	181	191	200	192	206	218	227	218	235	248	259	245	264	279	291	271	292	308	321	
	Lo PR	64	68	74	79	68	72	79	84	70	75	82	87	74	79	86	91	78	82	90	96	80	85	93	99	
	1725	MBh	46.4	47.8	51.8	55.5	45.4	46.7	50.6	54.3	44.3	45.6	49.3	53.0	43.2	44.5	48.1	51.7	41.0	42.3	45.7	49.1	38.0	39.1	42.4	45.5
	S/T	1.00	1.00	1.00	1.00	1.00	1.00	1.00	1.00	1.00	1.00	1.00	1.00	1.00	1.00	1.00	1.00	1.00	1.00	1.00	1.00	1.00	1.00	1.00	1.00	
	ΔT	25	25	28	30	24	25	27	29	24	24	26	28	23	24	26	28	22	23	24	26	20	21	23	24	
kW	3.42	3.48	3.57	3.67	3.64	3.71	3.81	3.92	3.84	3.92	4.03	4.15	4.02	4.10	4.22	4.34	4.17	4.25	4.38	4.51	4.30	4.38	4.51	4.65		
Amps	12.8	13.0	13.3	13.6	13.4	13.7	13.9	14.3	14.2	14.4	14.7	15.1	14.8	15.1	15.4	15.8	15.5	15.7	16.1	16.5	16.1	16.4	16.7	17.2		
Hi PR	149	160	169	176	167	179	190	198	190	204	216	225	216	233	246	256	243	262	276	288	269	289	305	318		
Lo PR	63	68	74	79	67	71	78	83	70	74	81	86	73	78	85	91	77	82	89	95	79	84	92	98		
1509	MBh	42.9	44.1	47.8	51.3	41.9	43.1	46.7	50.1	40.9	42.1	45.5	48.9	39.9	41.1	44.4	47.7	37.9	39.0	42.2	45.3	35.1	36.1	39.1	42.0	
S/T	1.00	1.00	1.00	1.00	1.00	1.00	1.00	1.00	1.00	1.00	1.00	1.00	1.00	1.00	1.00	1.00	1.00	1.00	1.00	1.00	1.00	1.00	1.00	1.00		
ΔT	26	27	29	31	26	26	28	31	25	26	28	30	24	25	27	29	23	24	26	28	21	22	24	26		
kW	3.34	3.41	3.50	3.59	3.56	3.63	3.73	3.84	3.76	3.83	3.94	4.05	3.93	4.01	4.12	4.24	4.07	4.15	4.28	4.40	4.20	4.28	4.41	4.54		
Amps	12.6	12.8	13.0	13.3	13.2	13.4	13.7	14.0	13.9	14.1	14.5	14.8	14.5	14.8	15.1	15.5	15.2	15.4	15.8	16.2	15.8	16.0	16.4	16.9		
Hi PR	144	155	164	171	162	174	184	192	184	198	209	218	210	226	238	248	236	254	268	279	261	280	296	309		
Lo PR	62	66	72	76	65	69	76	80	68	72	79	84	71	76	82	88	74	79	86	92	77	82	89	95		

Shaded area reflects ACCA (TVA) conditions IDB: Entering Indoor Dry Bulb Temperature kW = Total system power Amps = outdoor unit amps (comp. +fan)
 High and low pressures are measured at the liquid and suction service valves.

EXPANDED COOLING DATA — GPH1348M23AA (CONT.)

IDB	Airflow	Outdoor Ambient Temperature																								
		65°F				75°F				85°F				95°F				105°F				115°F				
		59	63	67	71	59	63	67	71	59	63	67	71	59	63	67	71	59	63	67	71	59	63	67	71	
80	1941	MBh	48.7	49.7	53.1	56.8	47.6	48.6	51.9	55.5	46.4	47.4	50.7	54.2	45.3	46.3	49.4	52.9	43.0	44.0	47.0	50.2	39.9	40.7	43.5	46.5
		S/T	1.00	1.00	1.00	1.00	1.00	1.00	1.00	1.00	1.00	1.00	1.00	1.00	1.00	1.00	1.00	1.00	1.00	1.00	1.00	1.00	1.00	1.00	1.00	1.00
	ΔT	23	24	25	27	23	23	23	25	26	22	22	24	26	21	22	23	25	20	21	22	24	19	19	21	22
	kW	3.46	3.53	3.62	3.72	3.69	3.76	3.87	3.98	3.90	3.97	4.09	4.21	4.08	4.16	4.28	4.41	4.23	4.31	4.44	4.58	4.36	4.45	4.58	4.72	
	Amps	13.0	13.1	13.4	13.7	13.6	13.8	14.1	14.5	14.4	14.6	14.9	15.3	15.0	15.3	15.6	16.0	15.7	15.9	16.3	16.7	16.3	16.6	17.0	17.4	
	Hi PR	152	163	172	180	170	183	193	202	194	208	220	229	220	237	250	261	248	267	282	294	274	295	311	325	
	Lo PR	65	69	75	80	68	73	79	85	71	76	83	88	75	79	87	92	78	83	91	97	81	86	94	100	
	MBh	47.3	48.3	51.6	55.2	46.2	47.2	50.4	53.9	45.1	46.1	49.2	52.6	44.0	44.9	48.0	51.3	41.8	42.7	45.6	48.7	38.7	39.5	42.2	45.2	
	S/T	1.00	1.00	1.00	1.00	1.00	1.00	1.00	1.00	1.00	1.00	1.00	1.00	1.00	1.00	1.00	1.00	1.00	1.00	1.00	1.00	1.00	1.00	1.00	1.00	1.00
	ΔT	25	26	28	29	25	25	27	29	24	25	26	28	23	24	26	27	22	23	24	26	21	21	23	24	
kW	3.44	3.50	3.60	3.70	3.67	3.74	3.84	3.95	3.87	3.94	4.06	4.18	4.05	4.13	4.25	4.37	4.20	4.28	4.41	4.54	4.33	4.42	4.55	4.69		
Amps	12.9	13.1	13.3	13.7	13.5	13.7	14.0	14.4	14.3	14.5	14.8	15.2	14.9	15.2	15.5	15.9	15.6	15.8	16.2	16.6	16.2	16.5	16.9	17.3		
Hi PR	150	162	171	178	168	181	191	200	192	206	218	227	218	235	248	259	246	264	279	291	271	292	308	322		
Lo PR	64	68	74	79	68	72	79	84	70	75	82	87	74	79	86	91	78	82	90	96	80	85	93	99		
MBh	43.6	44.6	47.6	50.9	42.6	43.5	46.5	49.7	41.6	42.5	45.4	48.5	40.6	41.5	44.3	47.4	38.6	39.4	42.1	45.0	35.7	36.5	39.0	41.7		
S/T	1.00	1.00	1.00	1.00	1.00	1.00	1.00	1.00	1.00	1.00	1.00	1.00	1.00	1.00	1.00	1.00	1.00	1.00	1.00	1.00	1.00	1.00	1.00	1.00	1.00	
ΔT	27	27	29	31	26	27	28	30	25	26	28	30	25	25	27	29	23	24	26	27	22	22	24	25		
kW	3.37	3.43	3.52	3.62	3.59	3.66	3.76	3.87	3.79	3.86	3.97	4.08	3.96	4.04	4.15	4.27	4.11	4.19	4.31	4.44	4.23	4.32	4.44	4.58		
Amps	12.7	12.9	13.1	13.4	13.3	13.5	13.8	14.1	14.0	14.2	14.5	14.9	14.6	14.9	15.2	15.6	15.3	15.5	15.9	16.3	15.9	16.1	16.5	17.0		
Hi PR	146	157	166	173	163	176	186	194	186	200	211	220	212	228	241	251	238	256	271	282	263	283	299	312		
Lo PR	62	66	72	77	66	70	76	81	68	73	79	84	72	76	83	89	75	80	87	93	78	83	90	96		

85	1941	MBh	49.5	50.5	52.9	56.4	48.4	49.3	51.7	55.1	47.2	48.1	50.4	53.8	46.1	47.0	49.2	52.5	43.8	44.6	46.7	49.9	40.5	41.3	43.3	46.2
		S/T	1.00	1.00	1.00	1.00	1.00	1.00	1.00	1.00	1.00	1.00	1.00	1.00	1.00	1.00	1.00	1.00	1.00	1.00	1.00	1.00	1.00	1.00	1.00	1.00
	ΔT	23	24	25	27	23	23	24	26	22	23	24	25	22	22	23	25	21	21	22	24	19	20	21	22	
	kW	3.49	3.55	3.65	3.75	3.72	3.79	3.90	4.01	3.93	4.00	4.12	4.24	4.11	4.19	4.31	4.44	4.26	4.35	4.48	4.61	4.39	4.48	4.62	4.76	
	Amps	13.0	13.2	13.5	13.8	13.7	13.9	14.2	14.5	14.4	14.7	15.0	15.4	15.1	15.3	15.7	16.1	15.8	16.0	16.4	16.8	16.4	16.7	17.1	17.5	
	Hi PR	153	165	174	182	172	185	195	204	195	210	222	232	223	240	253	264	250	270	285	297	277	298	314	328	
	Lo PR	65	70	76	81	69	74	80	85	72	76	83	89	75	80	88	93	79	84	92	98	82	87	95	101	
	MBh	48.1	49.0	51.3	54.8	47.0	47.9	50.1	53.5	45.9	46.7	49.0	52.2	44.7	45.6	47.8	51.0	42.5	43.3	45.4	48.4	39.4	40.1	42.0	44.8	
	S/T	1.00	1.00	1.00	1.00	1.00	1.00	1.00	1.00	1.00	1.00	1.00	1.00	1.00	1.00	1.00	1.00	1.00	1.00	1.00	1.00	1.00	1.00	1.00	1.00	1.00
	ΔT	26	26	27	29	25	26	27	29	24	25	26	28	24	24	25	27	23	23	24	26	21	21	22	24	
kW	3.46	3.53	3.62	3.72	3.69	3.76	3.87	3.98	3.90	3.97	4.09	4.21	4.08	4.16	4.28	4.41	4.23	4.31	4.44	4.58	4.36	4.45	4.58	4.72		
Amps	13.0	13.1	13.4	13.7	13.6	13.8	14.1	14.5	14.4	14.6	14.9	15.3	15.0	15.3	15.6	16.0	15.7	15.9	16.3	16.7	16.3	16.6	17.0	17.4		
Hi PR	152	163	172	180	170	183	193	202	194	208	220	229	220	237	250	261	248	267	282	294	274	295	311	325		
Lo PR	65	69	75	80	68	73	79	85	71	76	83	88	75	79	87	92	78	83	91	97	81	86	94	100		
MBh	44.4	45.2	47.4	50.6	43.4	44.2	46.3	49.4	42.3	43.1	45.2	48.2	41.3	42.1	44.1	47.0	39.2	40.0	41.9	44.7	36.3	37.0	38.8	41.4		
S/T	1.00	1.00	1.00	1.00	1.00	1.00	1.00	1.00	1.00	1.00	1.00	1.00	1.00	1.00	1.00	1.00	1.00	1.00	1.00	1.00	1.00	1.00	1.00	1.00	1.00	
ΔT	27	28	29	31	26	27	28	30	26	26	28	29	25	26	27	29	24	24	26	27	22	23	24	25		
kW	3.39	3.45	3.55	3.64	3.61	3.68	3.79	3.89	3.81	3.89	4.00	4.11	3.99	4.06	4.18	4.31	4.14	4.22	4.34	4.47	4.26	4.35	4.48	4.61		
Amps	12.7	12.9	13.2	13.5	13.4	13.6	13.9	14.2	14.1	14.3	14.6	15.0	14.7	15.0	15.3	15.7	15.4	15.6	16.0	16.4	16.0	16.3	16.6	17.1		
Hi PR	147	158	167	174	165	178	188	196	188	202	213	222	214	230	243	253	241	259	273	285	266	286	302	315		
Lo PR	63	67	73	78	66	71	77	82	69	73	80	85	72	77	84	90	76	81	88	94	79	84	91	97		

Shaded area reflects ARI conditions IDB: Entering Indoor Dry Bulb Temperature kW = Total system power Amps = outdoor unit amps (comp. +fan)
 High and low pressures are measured at the liquid and suction service valves.

EXPANDED COOLING DATA — GPH1348M24AA

IDB	Airflow	Outdoor Ambient Temperature																							
		65				75				85				95				105				115			
		59	63	67	71	59	63	67	71	59	63	67	71	59	63	67	71	59	63	67	71	59	63	67	71
70	MBh	47.04	48.75	53.41	-	45.94	47.62	52.17	-	44.85	46.48	50.93	-	43.75	45.35	49.69	-	41.57	43.08	47.2	-	38.5	39.91	43.72	-
	S/T	1	1	1	-	1	1	1	-	1	1	1	-	1	1	1	-	1	1	1	-	1	1	1	-
	ΔT	22	23	25	-	22	23	25	-	21	22	24	-	21	21	24	-	20	20	22	-	18	19	21	-
	kW	3.397	3.461	3.558	-	3.629	3.699	3.805	-	3.833	3.909	4.023	-	4.014	4.094	4.216	-	4.167	4.251	4.38	-	4.299	4.387	4.521	-
	Amps	6.486	6.592	6.741	-	6.845	6.96	7.122	-	7.259	7.386	7.563	-	7.617	7.753	7.944	-	7.975	8.121	8.325	-	8.329	8.484	8.701	-
	Hi PR	152.8	164.4	173.7	-	171.5	184.5	194.9	-	195	209.9	221.6	-	222.1	239.0	252.4	-	249.9	268.9	283.9	-	276.1	297.1	313.7	-
	Lo PR	65.02	69.17	75.52	-	68.7	73.08	79.79	-	71.4	75.96	82.92	-	75	79.79	87.10	-	78.59	83.62	91.28	-	81.29	86.49	94.42	-
	MBh	45.67	47.33	51.86	-	44.6	46.23	50.65	-	43.54	45.13	49.45	-	42.48	44.03	48.24	-	40.36	41.83	45.83	-	37.38	38.75	42.45	-
	S/T	1	1	1	-	1	1	1	-	1	1	1	-	1	1	1	-	1	1	1	-	1	1	1	-
	ΔT	24	25	28	-	24	25	27	-	23	24	26	-	23	23	26	-	22	22	24	-	20	21	23	-
kW	3.374	3.437	3.533	-	3.603	3.672	3.777	-	3.805	3.88	3.994	-	3.984	4.063	4.184	-	4.136	4.219	4.346	-	4.267	4.354	4.486	-	
Amps	6.447	6.552	6.699	-	6.802	6.916	7.076	-	7.212	7.337	7.513	-	7.567	7.701	7.89	-	7.921	8.065	8.267	-	8.271	8.424	8.639	-	
Hi PR	151.3	162.8	171.9	-	169.8	182.7	192.9	-	193.1	207.8	219.4	-	219.9	236.7	249.9	-	247.4	266.2	281.1	-	273.4	294.2	310.6	-	
Lo PR	64.38	68.49	74.77	-	68.02	72.36	79	-	70.69	75.2	82.1	-	74.25	79.00	86.24	-	77.82	82.79	90.38	-	80.49	85.63	93.48	-	
MBh	42.15	43.69	47.86	-	41.17	42.67	46.75	-	40.19	41.66	45.64	-	39.21	40.64	44.53	-	37.25	38.61	42.3	-	34.5	35.76	39.18	-	
S/T	1	1	1	-	1	1	1	-	1	1	1	-	1	1	1	-	1	1	1	-	1	1	1	-	
ΔT	26	27	29	-	25	26	28	-	24	25	28	-	24	25	27	-	23	24	26	-	21	22	24	-	
kW	3.303	3.364	3.457	-	3.525	3.592	3.694	-	3.721	3.794	3.904	-	3.895	3.972	4.089	-	4.042	4.123	4.246	-	4.169	4.253	4.382	-	
Amps	6.328	6.43	6.573	-	6.672	6.783	6.939	-	7.071	7.192	7.362	-	7.415	7.545	7.728	-	7.759	7.898	8.094	-	8.098	8.247	8.455	-	
Hi PR	146.8	157.9	166.8	-	164.7	177.2	187.1	-	187.3	201.5	212.8	-	213.3	229.6	242.4	-	240	258.3	272.7	-	265.2	285.3	301.3	-	
Lo PR	62.45	66.43	72.53	-	65.97	70.19	76.63	-	68.57	72.95	79.64	-	72.03	76.63	83.65	-	75.48	80.3	87.67	-	78.08	83.06	90.68	-	

75	MBh	47.83	49.25	53.31	57.21	46.72	48.1	52.07	55.88	45.61	46.96	50.83	54.55	44.5	45.81	49.59	53.22	42.27	43.52	47.11	50.56	39.16	40.32	43.64	46.83
	S/T	1	1	1	1	1	1	1	1	1	1	1	1	1	1	1	1	1	1	1	1	1	1	1	1
	ΔT	23	23	25	27	22	23	25	26	22	22	24	26	21	22	23	25	20	21	22	24	19	19	21	22
	kW	3.422	3.486	3.584	3.687	3.656	3.726	3.834	3.947	3.862	3.938	4.054	4.176	4.044	4.125	4.249	4.378	4.199	4.285	4.414	4.55	4.333	4.422	4.557	4.699
	Amps	6.527	6.634	6.784	6.96	6.889	7.006	7.169	7.36	7.308	7.435	7.614	7.824	7.669	7.807	7.999	8.225	8.031	8.178	8.384	8.626	8.388	8.545	8.764	9.021
	Hi PR	154.4	166.1	175.4	183	173.2	186.4	196.8	205.3	197	212	223.9	233.5	224.4	241.5	255.0	265.9	252.4	271.6	286.8	299.2	278.9	300.1	316.9	330.6
	Lo PR	65.68	69.88	76.29	81.25	69.4	73.83	80.6	85.94	72.12	76.73	83.77	89.21	75.76	80.6	87.99	93.71	79.4	84.47	92.21	98.21	82.12	87.37	95.38	101.6
	MBh	46.44	47.81	51.75	55.55	45.36	46.7	50.55	54.25	44.28	45.59	49.35	52.96	43.2	44.48	48.14	51.67	41.04	42.25	45.74	49.09	38.02	39.14	42.37	45.47
	S/T	1	1	1	1	1	1	1	1	1	1	1	1	1	1	1	1	1	1	1	1	1	1	1	1
	ΔT	25	25	28	30	24	25	27	29	24	24	26	28	23	24	26	28	22	23	24	26	20	21	23	24
kW	3.398	3.462	3.559	3.661	3.629	3.699	3.806	3.918	3.834	3.909	4.024	4.145	4.014	4.095	4.217	4.345	4.168	4.252	4.38	4.515	4.3	4.388	4.521	4.662	
Amps	6.487	6.593	6.742	6.916	6.845	6.961	7.123	7.312	7.26	7.387	7.564	7.771	7.618	7.754	7.945	8.168	7.977	8.122	8.326	8.565	8.33	8.485	8.702	8.956	
Hi PR	152.8	164.5	173.7	181.2	171.5	184.6	194.9	203.3	195.1	209.9	221.7	231.2	222.2	239.1	252.5	263.3	249.9	269	284	296.2	276.1	297.2	313.8	327.3	
Lo PR	65.03	69.19	75.53	80.44	68.71	73.1	79.8	84.99	71.41	75.97	82.94	88.33	75.01	79.8	87.12	92.78	78.61	83.63	91.3	97.24	81.31	86.51	94.44	100.6	
MBh	42.86	44.13	47.77	51.27	41.87	43.11	46.66	50.08	40.87	42.08	45.55	48.88	39.87	41.05	44.44	47.69	37.88	39	42.22	45.31	35.09	36.13	39.1	41.97	
S/T	1	1	1	1	1	1	1	1	1	1	1	1	1	1	1	1	1	1	1	1	1	1	1	1	
ΔT	26	27	29	31	26	26	28	31	25	26	28	30	24	25	27	29	23	24	26	28	21	22	24	26	
kW	3.326	3.388	3.482	3.581	3.551	3.619	3.722	3.83	3.749	3.822	3.933	4.051	3.924	4.002	4.120	4.245	4.073	4.155	4.279	4.41	4.201	4.287	4.416	4.552	
Amps	6.368	6.47	6.614	6.783	6.715	6.827	6.984	7.168	7.117	7.24	7.412	7.613	7.465	7.597	7.782	7.998	7.812	7.954	8.151	8.383	8.155	8.305	8.516	8.762	
Hi PR	148.3	159.5	168.5	175.7	166.4	179	189	197.2	189.2	203.6	215	224.2	215.5	231.9	244.9	255.4	242.4	260.9	275.5	287.3	267.9	288.2	304.4	317.5	
Lo PR	63.08	67.11	73.27	78.03	66.65	70.91	77.41	82.44	69.27	73.69	80.45	85.68	72.76	77.41	84.51	90	76.25	81.12	88.56	94.32	78.87	83.91	91.6	97.56	

Shaded area reflects ACCA (TVA) conditions IDB: Entering Indoor Dry Bulb Temperature kW = Total system power Amps = outdoor unit amps (comp. +fan)
 High and low pressures are measured at the liquid and suction service valves.

EXPANDED COOLING DATA — GPH1348M24AA (CONT.)

		Outdoor Ambient Temperature																											
		65					75					85					95					105					115		
IDB	Airflow	59	63	67	71	59	63	67	71	59	63	67	71	59	63	67	71	59	63	67	71	59	63	67	71	59	63	67	71
1941	MBh	48.68	49.75	53.15	56.82	47.55	48.59	51.91	55.49	46.42	47.43	50.68	54.17	45.29	46.28	49.44	52.85	43.02	43.96	46.97	50.21	39.85	40.72	43.51	46.51				
	S/T	1	1	1	1	1	1	1	1	1	1	1	1	1	1	1	1	1	1	1	1	1	1	1	1	1	1	1	
	ΔT	23	24	25	27	23	23	25	26	22	22	24	26	21	22	23	25	20	21	22	24	19	19	21	22				
	kW	3.446	3.511	3.61	3.714	3.682	3.754	3.862	3.977	3.891	3.968	4.085	4.208	4.075	4.157	4.281	4.412	4.232	4.318	4.448	4.586	4.367	4.456	4.592	4.736				
	Amps	6.568	6.676	6.827	7.005	6.933	7.051	7.216	7.41	7.356	7.485	7.666	7.878	7.722	7.861	8.055	8.283	8.087	8.236	8.444	8.688	8.448	8.606	8.827	9.087				
	Hi PR	155.9	167.8	177.2	184.8	175	188.3	198.8	207.4	199	214.1	226.1	235.9	226.6	243.9	257.6	268.6	255	274.4	289.7	302.2	281.7	303.2	320.1	333.9				
	Lo PR	66.35	70.59	77.06	82.07	70.1	74.58	81.41	86.71	72.85	77.51	84.61	90.11	76.53	81.41	88.88	94.66	80.2	85.32	93.15	99.2	82.95	88.25	96.35	102.6				
	MBh	47.27	48.3	51.6	55.16	46.17	47.17	50.4	53.88	45.07	46.05	49.2	52.59	43.97	44.93	48	51.31	41.77	42.68	45.6	48.75	38.69	39.54	42.24	45.15				
	S/T	1	1	1	1	1	1	1	1	1	1	1	1	1	1	1	1	1	1	1	1	1	1	1	1	1	1	1	
	ΔT	25	26	28	29	25	25	27	29	24	25	26	28	23	24	26	27	22	23	24	26	21	21	23	24				
kW	3.422	3.486	3.584	3.687	3.656	3.727	3.834	3.947	3.862	3.939	4.054	4.176	4.045	4.126	4.249	4.379	4.2	4.285	4.414	4.551	4.333	4.422	4.557	4.699					
Amps	6.527	6.635	6.785	6.96	6.889	7.006	7.17	7.361	7.308	7.436	7.615	7.825	7.67	7.808	8	8.226	8.032	8.179	8.385	8.626	8.389	8.545	8.765	9.021					
Hi PR	154.4	166.1	175.4	183	173.2	186.4	196.9	205.3	197	212	223.9	233.5	224.4	241.5	255	266	252.5	271.7	286.9	299.2	278.9	300.2	317	330.6					
Lo PR	65.69	69.89	76.3	81.26	69.4	73.84	80.61	85.85	72.13	76.74	83.78	89.22	75.77	80.61	88	93.72	79.4	84.48	92.22	98.22	82.13	87.38	95.39	101.6					
MBh	43.63	44.58	47.63	50.91	42.61	43.54	46.52	49.73	41.6	42.51	45.41	48.55	40.58	41.47	44.30	47.36	38.55	39.4	42.09	44.99	35.71	36.49	38.99	41.68					
S/T	1	1	1	1	1	1	1	1	1	1	1	1	1	1	1	1	1	1	1	1	1	1	1	1	1	1	1		
ΔT	27	27	29	31	26	27	28	30	25	26	28	30	25	25	27	29	23	24	26	27	22	22	24	25					
kW	3.35	3.412	3.507	3.607	3.576	3.645	3.749	3.859	3.777	3.851	3.963	4.081	3.954	4.032	4.152	4.278	4.104	4.187	4.312	4.444	4.234	4.32	4.45	4.588					
Amps	6.407	6.511	6.656	6.826	6.758	6.871	7.029	7.215	7.164	7.288	7.462	7.665	7.515	7.648	7.835	8.054	7.866	8.009	8.208	8.442	8.212	8.364	8.577	8.826					
Hi PR	149.8	161.2	170.2	177.5	168	180.8	191	199.2	191.1	205.7	217.2	226.5	217.7	234.2	247.4	258	244.9	263.5	278.3	290.2	270.6	291.2	307.5	320.7					
Lo PR	63.72	67.79	74.01	78.82	67.32	71.62	78.19	83.27	69.97	74.44	81.26	86.54	73.49	78.19	85.36	90.91	77.02	81.94	89.46	95.27	79.67	84.76	92.53	98.54					
MBh	49.53	50.49	52.88	56.42	48.38	49.32	51.65	55.11	47.23	48.14	50.42	53.79	46.08	46.97	49.19	52.48	43.77	44.62	46.73	49.86	40.55	41.33	43.29	46.18					
S/T	1	1	1	1	1	1	1	1	1	1	1	1	1	1	1	1	1	1	1	1	1	1	1	1	1	1	1		
ΔT	23	24	25	27	23	23	24	26	22	22	23	24	25	22	22	23	25	21	21	22	24	19	20	21	22				
kW	3.471	3.536	3.636	3.741	3.709	3.781	3.891	4.006	3.92	3.998	4.116	4.24	4.106	4.188	4.314	4.446	4.264	4.351	4.483	4.622	4.4	4.491	4.628	4.773					
Amps	6.608	6.718	6.871	7.05	6.978	7.097	7.263	7.459	7.405	7.535	7.718	7.932	7.774	7.914	8.111	8.341	8.143	8.293	8.503	8.749	8.507	8.667	8.89	9.152					
Hi PR	157.5	169.5	179	186.7	176.7	190.2	200.8	209.5	201	216.3	228.4	238.2	228.9	246.3	260.1	271.3	257.5	277.1	292.6	305.2	284.5	306.2	323.3	337.2					
Lo PR	67.01	71.29	77.83	82.89	70.8	75.32	82.23	87.57	73.58	78.28	85.46	91.01	77.29	82.23	89.77	95.6	81	86.18	94.08	100.2	83.78	89.14	97.31	103.6					
MBh	48.09	49.02	51.34	54.77	46.97	47.88	50.15	53.5	45.85	46.74	48.95	52.23	44.74	45.60	47.76	50.95	42.5	43.32	45.37	48.41	39.37	40.13	42.03	44.84					
S/T	1	1	1	1	1	1	1	1	1	1	1	1	1	1	1	1	1	1	1	1	1	1	1	1	1	1	1		
ΔT	26	26	27	29	25	26	27	29	24	25	26	28	24	24	25	27	23	23	24	26	21	21	22	24					
kW	3.446	3.511	3.61	3.714	3.682	3.754	3.862	3.977	3.891	3.968	4.085	4.208	4.075	4.157	4.281	4.412	4.232	4.318	4.448	4.586	4.367	4.456	4.592	4.736					
Amps	6.568	6.676	6.827	7.005	6.933	7.051	7.216	7.41	7.356	7.485	7.666	7.878	7.722	7.861	8.055	8.283	8.087	8.236	8.444	8.688	8.448	8.606	8.827	9.087					
Hi PR	155.9	167.8	177.2	184.8	175	188.3	198.8	207.4	199	214.1	226.1	235.9	226.6	243.9	257.6	268.6	255	274.4	289.7	302.2	281.7	303.2	320.1	333.9					
Lo PR	66.35	70.59	77.06	82.07	70.1	74.58	81.41	86.71	72.85	77.51	84.61	90.11	76.53	81.41	88.88	94.66	80.2	85.32	93.15	99.2	82.95	88.25	96.35	102.6					
MBh	44.39	45.25	47.39	50.56	43.36	44.2	46.29	49.38	42.32	43.14	45.18	48.21	41.29	42.09	44.08	47.03	39.23	39.99	41.88	44.68	36.34	37.04	38.79	41.39					
S/T	1	1	1	1	1	1	1	1	1	1	1	1	1	1	1	1	1	1	1	1	1	1	1	1	1	1	1		
ΔT	27	28	29	31	26	27	28	30	26	26	28	29	25	26	27	29	24	24	26	27	29	24	24	25	25				
kW	3.373	3.436	3.532	3.633	3.602	3.671	3.777	3.887	3.805	3.879	3.993	4.112	3.983	4.062	4.183	4.31	4.135	4.218	4.345	4.479	4.266	4.353	4.485	4.624					
Amps	6.446	6.551	6.698	6.87	6.8	6.915	7.075	7.262	7.21	7.336	7.511	7.717	7.565	7.700	7.888	8.109	7.92	8.064	8.266	8.502	8.269	8.423	8.637	8.889					
Hi PR	151.3	162.8	171.9	179.3	169.7	182.6	192.9	201.2	193	207.7	219.3	228.8	219.8	236.6	249.8	260.6	247.3	266.2	281.1	293.1	273.3	294.1	310.5	323.9					
Lo PR	64.36	68.47	74.75	79.61	67.99	72.34	78.97	84.1	70.67	75.18	82.08	87.41	74.23	78.97	86.21	91.82	77.79	82.76	90.35	96.22	80.47	85.61	93.46	99.53					

Shaded area reflects ARI conditions IDB: Entering Indoor Dry Bulb Temperature kW = Total system power Amps = outdoor unit amps (comp. +fan)
 High and low pressures are measured at the liquid and suction service valves.

EXPANDED COOLING DATA — GPH1360M23AA

IDB		Outdoor Ambient Temperature																																			
		65						75						85						95						105						115					
		59	63	67	71	59	63	67	71	59	63	67	71	59	63	67	71	59	63	67	71	59	63	67	71	59	63	67	71								
70	Airflow	Entering Indoor Wet Bulb Temperature																																			
	MBh	55.4	57.4	62.9	-	54.1	56.1	61.4	-	52.8	54.7	59.9	-	51.5	53.4	58.5	-	48.9	50.7	55.6	-	45.3	47.0	51.5	-												
	S/T	1.00	1.00	1.00	-	1.00	1.00	1.00	-	1.00	1.00	1.00	-	1.00	1.00	1.00	-	1.00	1.00	1.00	-	1.00	1.00	1.00	-												
	ΔT	24	25	28	-	23	24	26	-	23	24	26	-	23	24	26	-	22	22	25	-	20	21	23	-												
	kW	4.31	4.39	4.52	-	4.61	4.71	4.85	-	4.88	4.98	5.13	-	5.12	5.23	5.39	-	5.32	5.43	5.60	-	5.50	5.61	5.79	-												
	Amps	16.1	16.4	16.7	-	17.0	17.2	17.6	-	17.9	18.2	18.7	-	18.8	19.1	19.6	-	19.6	20.0	20.5	-	20.5	20.8	21.4	-												
	Hi Pr	153	165	174	-	172	185	196	-	196	211	222	-	223	240	253	-	251	270	285	-	277	298	315	-												
	Lo Pr	44	46	51	-	46	49	53	-	48	51	56	-	50	53	58	-	53	56	61	-	55	58	63	-												
	MBh	53.8	55.7	61.0	-	52.5	54.4	59.6	-	51.3	53.1	58.2	-	50.0	51.8	56.8	-	47.5	49.2	53.9	-	44.0	45.6	50.0	-												
	S/T	1.00	1.00	1.00	-	1.00	1.00	1.00	-	1.00	1.00	1.00	-	1.00	1.00	1.00	-	1.00	1.00	1.00	-	1.00	1.00	1.00	-												
ΔT	27	28	30	-	26	27	30	-	25	26	29	-	25	26	28	-	24	24	27	-	22	23	25	-													
kW	4.28	4.36	4.49	-	4.58	4.67	4.81	-	4.85	4.94	5.09	-	5.08	5.19	5.35	-	5.28	5.39	5.56	-	5.45	5.57	5.74	-													
Amps	16.0	16.3	16.6	-	16.9	17.1	17.5	-	17.8	18.1	18.5	-	18.7	19.0	19.4	-	19.5	19.9	20.3	-	20.3	20.7	21.2	-													
Hi Pr	152	163	173	-	170	183	194	-	194	209	220	-	221	238	251	-	248	267	282	-	274	295	312	-													
Lo Pr	43	46	50	-	46	49	53	-	47	50	55	-	50	53	58	-	52	56	61	-	54	57	63	-													
MBh	49.6	51.4	56.3	-	48.5	50.2	55.0	-	47.3	49.0	53.7	-	46.2	47.8	52.4	-	43.8	45.4	49.8	-	40.6	42.1	46.1	-													
S/T	1.00	1.00	1.00	-	1.00	1.00	1.00	-	1.00	1.00	1.00	-	1.00	1.00	1.00	-	1.00	1.00	1.00	-	1.00	1.00	1.00	-													
ΔT	28	29	32	-	28	29	31	-	27	28	31	-	26	27	30	-	25	26	28	-	23	24	26	-													
kW	4.18	4.27	4.39	-	4.48	4.57	4.70	-	4.74	4.83	4.98	-	4.96	5.07	5.22	-	5.16	5.26	5.43	-	5.33	5.44	5.61	-													
Amps	15.7	16.0	16.3	-	16.6	16.8	17.2	-	17.5	17.8	18.2	-	18.3	18.6	19.1	-	19.1	19.5	19.9	-	19.9	20.3	20.8	-													
Hi Pr	147	159	167	-	165	178	188	-	188	202	214	-	214	230	243	-	241	259	274	-	266	286	302	-													
Lo Pr	42	45	49	-	44	47	51	-	46	49	53	-	48	51	56	-	51	54	59	-	52	56	61	-													

2081	MBh	56.30	57.97	62.75	67.34	54.99	56.62	61.29	65.78	53.68	55.27	59.83	64.21	52.38	53.93	58.37	62.65	49.76	51.23	55.45	59.51	46.09	47.45	51.37	55.13
	S/T	1.00	1.00	1.00	1.00	1.00	1.00	1.00	1.00	1.00	1.00	1.00	1.00	1.00	1.00	1.00	1.00	1.00	1.00	1.00	1.00	1.00	1.00	1.00	1.00
	ΔT	25	26	28	30	24	25	27	29	24	24	26	28	23	24	26	28	22	23	24	26	20	21	23	24
	kW	4.34	4.43	4.56	4.69	4.65	4.74	4.88	5.03	4.92	5.02	5.17	5.33	5.16	5.27	5.43	5.60	5.37	5.48	5.65	5.83	5.54	5.66	5.84	6.02
	Amps	16.2	16.5	16.8	17.2	17.1	17.3	17.7	18.2	18.1	18.4	18.8	19.3	18.9	19.2	19.7	20.2	19.8	20.1	20.6	21.2	20.6	21.0	21.5	22.1
	Hi Pr	155	167	176	184	174	187	198	206	198	213	225	234	225	242	256	267	253	273	288	300	280	301	318	332
	Lo Pr	44	47	51	54	47	49	54	58	48	51	56	60	51	54	59	63	53	57	62	66	55	59	64	68
	MBh	54.7	56.3	60.9	65.4	53.4	55.0	59.5	63.9	52.1	53.7	58.1	62.3	50.9	52.4	56.7	60.8	48.3	49.7	53.8	57.8	44.7	46.1	49.9	53.5
	S/T	1.00	1.00	1.00	1.00	1.00	1.00	1.00	1.00	1.00	1.00	1.00	1.00	1.00	1.00	1.00	1.00	1.00	1.00	1.00	1.00	1.00	1.00	1.00	1.00
	ΔT	27	28	30	32	27	27	30	32	26	27	29	31	25	26	28	30	24	25	27	29	22	23	25	27
kW	4.31	4.39	4.52	4.66	4.61	4.71	4.85	4.99	4.88	4.98	5.13	5.29	5.12	5.23	5.39	5.56	5.32	5.44	5.60	5.78	5.50	5.61	5.79	5.98	
Amps	16.1	16.4	16.7	17.1	17.0	17.2	17.6	18.1	17.9	18.2	18.7	19.2	18.8	19.1	19.6	20.1	19.6	20.0	20.5	21.0	20.5	20.9	21.4	22.0	
Hi Pr	153	165	174	182	172	185	196	204	196	211	223	232	223	240	253	264	251	270	285	297	277	298	315	329	
Lo Pr	44	46	51	54	46	49	54	57	48	51	56	59	50	54	58	62	53	56	61	65	55	58	63	67	
MBh	50.5	51.9	56.2	60.3	49.3	50.7	54.9	58.9	48.1	49.5	53.6	57.5	46.9	48.3	52.3	56.1	44.6	45.9	49.7	53.3	41.3	42.5	46.0	49.4	
S/T	1.00	1.00	1.00	1.00	1.00	1.00	1.00	1.00	1.00	1.00	1.00	1.00	1.00	1.00	1.00	1.00	1.00	1.00	1.00	1.00	1.00	1.00	1.00	1.00	
ΔT	29	30	32	34	28	29	31	33	27	28	30	33	27	27	30	32	25	26	28	30	23	24	26	28	
kW	4.22	4.30	4.42	4.55	4.51	4.60	4.74	4.88	4.77	4.87	5.02	5.17	5.00	5.11	5.26	5.43	5.20	5.31	5.47	5.64	5.37	5.48	5.65	5.83	
Amps	15.8	16.1	16.4	16.8	16.7	16.9	17.3	17.7	17.6	17.9	18.3	18.8	18.4	18.7	19.2	19.7	19.3	19.6	20.1	20.6	20.1	20.4	20.9	21.5	
Hi Pr	149	160	169	176	167	180	190	198	190	204	216	225	216	233	246	256	243	262	277	288	269	289	306	319	
Lo Pr	42	45	49	52	45	48	52	55	46	49	54	57	49	52	57	60	51	54	59	63	53	56	61	65	

Shaded area reflects ACCA (TVA) conditions IDB: Entering Indoor Dry Bulb Temperature kW = Total system power Amps = outdoor unit amps (comp.+fan)
 High and low pressures are measured at the liquid and suction service valves.

EXPANDED COOLING DATA — GPH1360M23AA (CONT.)

IDB	Airflow	Outdoor Ambient Temperature																							
		65				75				85				95				105				115			
		59	63	67	71	59	63	67	71	59	63	67	71	59	63	67	71	59	63	67	71	59	63	67	71
80	MBh	57.30	58.56	62.56	66.88	55.97	57.19	61.10	65.32	54.64	55.83	59.65	63.77	53.31	54.47	58.20	62.21	50.64	51.75	55.29	59.10	46.91	47.93	51.21	54.75
	S/T	1.00	1.00	1.00	1.00	1.00	1.00	1.00	1.00	1.00	1.00	1.00	1.00	1.00	1.00	1.00	1.00	1.00	1.00	1.00	1.00	1.00	1.00	1.00	1.00
	ΔT	25	26	28	30	25	27	29	32	24	25	26	28	24	24	26	27	22	23	24	26	21	21	23	24
	KW	4.37	4.46	4.59	4.73	4.68	4.78	4.92	5.07	4.96	5.06	5.21	5.38	5.20	5.31	5.47	5.65	5.41	5.52	5.69	5.88	5.59	5.70	5.88	6.07
	Amps	16.3	16.6	16.9	17.3	17.2	17.4	17.8	18.3	18.2	18.5	18.9	19.4	19.0	19.4	19.8	20.4	19.9	20.3	20.8	21.3	20.8	21.1	21.7	22.3
	Hi Pr	157	168	178	186	176	189	200	208	200	215	227	237	228	245	259	270	256	275	291	303	283	304	321	335
	Lo Pr	44	47	52	55	47	50	55	58	49	52	57	60	51	55	60	63	54	57	62	67	56	59	65	69
	MBh	55.6	56.9	60.7	64.9	54.3	55.5	59.3	63.4	53.0	54.2	57.9	61.9	51.8	52.9	56.5	60.4	49.2	50.2	53.7	57.4	45.5	46.5	49.7	53.2
	S/T	1.00	1.00	1.00	1.00	1.00	1.00	1.00	1.00	1.00	1.00	1.00	1.00	1.00	1.00	1.00	1.00	1.00	1.00	1.00	1.00	1.00	1.00	1.00	1.00
	ΔT	28	28	30	32	27	28	29	32	26	27	29	31	26	26	28	30	24	25	27	29	23	23	25	26
	KW	4.34	4.43	4.56	4.69	4.65	4.74	4.88	5.03	4.92	5.02	5.17	5.34	5.16	5.27	5.43	5.60	5.37	5.48	5.65	5.83	5.54	5.66	5.84	6.02
	Amps	16.2	16.5	16.8	17.2	17.1	17.3	17.7	18.2	18.1	18.4	18.8	19.3	18.9	19.2	19.7	20.2	19.8	20.1	20.6	21.2	20.6	21.0	21.5	22.1
Hi Pr	155	167	176	184	174	187	198	206	198	213	225	234	225	242	256	267	253	273	288	300	280	301	318	332	
Lo Pr	44	47	51	54	47	50	54	58	48	51	56	60	51	54	59	63	53	57	62	66	55	59	64	68	
MBh	51.4	52.5	56.1	59.9	50.2	51.3	54.8	58.5	49.0	50.0	53.5	57.1	47.8	48.8	52.1	55.7	45.4	46.4	49.5	53.0	42.0	43.0	45.9	49.1	
S/T	1.00	1.00	1.00	1.00	1.00	1.00	1.00	1.00	1.00	1.00	1.00	1.00	1.00	1.00	1.00	1.00	1.00	1.00	1.00	1.00	1.00	1.00	1.00	1.00	
ΔT	29	30	32	34	28	29	31	33	28	28	30	32	27	28	30	32	26	26	28	30	24	24	26	28	
KW	4.25	4.33	4.45	4.59	4.54	4.64	4.77	4.92	4.81	4.91	5.05	5.21	5.04	5.15	5.30	5.47	5.24	5.35	5.51	5.69	5.41	5.52	5.70	5.88	
Amps	15.9	16.2	16.5	16.9	16.8	17.0	17.4	17.8	17.7	18.0	18.4	18.9	18.5	18.9	19.3	19.8	19.4	19.7	20.2	20.7	20.2	20.6	21.1	21.7	
Hi Pr	150	162	171	178	169	182	192	200	192	206	218	227	219	235	248	259	246	265	279	291	272	292	309	322	
Lo Pr	43	45	50	53	45	48	52	56	47	50	54	58	49	52	57	61	52	55	60	64	53	57	62	66	
85	MBh	58.31	59.43	62.25	66.41	56.95	58.05	60.80	64.86	55.59	56.67	59.35	63.32	54.24	55.29	57.90	61.77	51.53	52.52	55.01	58.69	47.73	48.65	50.96	54.36
	S/T	1.00	1.00	1.00	1.00	1.00	1.00	1.00	1.00	1.00	1.00	1.00	1.00	1.00	1.00	1.00	1.00	1.00	1.00	1.00	1.00	1.00	1.00	1.00	1.00
	ΔT	26	26	27	29	25	26	27	29	25	25	26	28	24	24	26	27	23	23	24	26	21	21	23	24
	KW	4.41	4.49	4.62	4.76	4.72	4.81	4.96	5.11	5.00	5.10	5.26	5.42	5.24	5.35	5.52	5.69	5.45	5.57	5.74	5.92	5.63	5.75	5.93	6.12
	Amps	16.4	16.7	17.0	17.4	17.3	17.6	18.0	18.4	18.3	18.6	19.0	19.5	19.2	19.5	20.0	20.5	20.0	20.4	20.9	21.5	20.9	21.3	21.8	22.4
	Hi Pr	158	170	180	187	177	191	202	210	202	217	229	239	230	247	261	272	259	278	294	306	286	307	325	339
	Lo Pr	45	48	52	56	47	50	55	59	49	52	57	61	52	55	60	64	54	58	63	67	56	60	65	69
	MBh	56.6	57.7	60.4	64.5	55.3	56.4	59.0	63.0	54.0	55.0	57.6	61.5	52.7	53.7	56.2	60.0	50.0	51.0	53.4	57.0	46.3	47.2	49.5	52.8
	S/T	1.00	1.00	1.00	1.00	1.00	1.00	1.00	1.00	1.00	1.00	1.00	1.00	1.00	1.00	1.00	1.00	1.00	1.00	1.00	1.00	1.00	1.00	1.00	1.00
	ΔT	28	29	30	32	27	28	29	31	27	27	29	31	26	27	28	30	25	25	27	28	23	23	25	26
	KW	4.37	4.46	4.59	4.73	4.68	4.78	4.92	5.07	4.96	5.06	5.21	5.38	5.20	5.31	5.47	5.65	5.41	5.52	5.69	5.88	5.59	5.70	5.88	6.07
	Amps	16.3	16.6	16.9	17.3	17.2	17.4	17.8	18.3	18.2	18.5	18.9	19.4	19.0	19.4	19.8	20.4	19.9	20.3	20.8	21.3	20.8	21.1	21.7	22.3
Hi Pr	157	168	178	186	176	189	200	208	200	215	227	237	228	245	259	270	256	275	291	303	283	304	321	335	
Lo Pr	44	47	52	55	47	50	55	58	49	52	57	60	51	55	60	63	54	57	62	67	56	59	65	69	
MBh	52.2	53.3	55.8	59.5	51.0	52.0	54.5	58.1	49.8	50.8	53.2	56.7	48.6	49.5	51.9	55.4	46.2	47.1	49.3	52.6	42.8	43.6	45.7	48.7	
S/T	1.00	1.00	1.00	1.00	1.00	1.00	1.00	1.00	1.00	1.00	1.00	1.00	1.00	1.00	1.00	1.00	1.00	1.00	1.00	1.00	1.00	1.00	1.00	1.00	
ΔT	30	30	32	34	29	30	31	33	28	29	30	32	28	28	29	31	26	27	28	30	24	25	26	28	
KW	4.28	4.36	4.49	4.62	4.58	4.67	4.81	4.96	4.85	4.94	5.09	5.25	5.08	5.19	5.34	5.51	5.28	5.39	5.56	5.73	5.45	5.57	5.74	5.93	
Amps	16.0	16.3	16.6	17.0	16.9	17.1	17.5	17.9	17.8	18.1	18.5	19.0	18.7	19.0	19.4	20.0	19.5	19.9	20.3	20.9	20.3	20.7	21.2	21.8	
Hi Pr	152	163	173	180	170	183	194	202	194	209	220	230	221	238	251	262	248	267	282	294	274	295	312	325	
Lo Pr	43	46	50	53	46	48	53	56	47	50	55	59	50	53	58	62	52	55	61	65	54	57	63	67	

Shaded area reflects ARI conditions
 High and low pressures are measured at the liquid and suction service valves.
 IDB: Entering Indoor Dry Bulb Temperature
 kW = Total system power
 Amps = outdoor unit amps (comp.+fan)

EXPANDED COOLING DATA — GPH1360M24AA

IDB	Airflow	Outdoor Ambient Temperature																															
		65					75					85					95					105					115						
		59	63	67	71	75	59	63	67	71	75	59	63	67	71	75	59	63	67	71	75	59	63	67	71	75	59	63	67	71	75		
	MBh	55.37	57.38	62.87	-	54.08	56.05	61.41	-	52.79	54.72	59.95	-	51.5	53.38	-	48.93	50.71	55.56	-	45.32	46.98	51.47	-									
	S/T	1	1	1	-	1	1	1	-	1	1	1	-	1	1	1	-	1	1	1	-	1	1	1	-								
	ΔT	24	25	28	-	24	25	27	-	23	24	26	-	23	24	26	-	22	23	25	-	20	21	23	-								
2081	KW	4.304	4.388	4.517	-	4.61	4.703	4.844	-	4.881	4.981	5.132	-	5.12	5.226	5.387	-	5.323	5.434	5.604	-	5.498	5.614	5.791	-								
	Amps	7.266	7.388	7.558	-	7.676	7.809	7.994	-	8.151	8.296	8.499	-	8.562	8.717	8.936	-	8.972	9.139	9.372	-	9.376	9.554	9.803	-								
	Hi PR	156.4	168.3	177.7	-	175.5	188.9	199.4	-	199.6	214.8	226.8	-	227.3	244.6	258.3	-	255.8	275.2	290.6	-	282.6	304.1	321.1	-								
	Lo PR	62.8	66.82	72.94	-	66.35	70.59	77.07	-	68.96	73.37	80.09	-	72.44	77.07	84.13	-	75.92	80.76	88.17	-	78.52	83.54	91.2	-								
	MBh	53.75	55.71	61.04	-	52.5	54.42	59.62	-	51.25	53.12	58.2	-	50	51.83	56.78	-	47.5	49.24	53.94	-	44	45.61	49.97	-								
	S/T	1	1	1	-	1	1	1	-	1	1	1	-	1	1	1	-	1	1	1	-	1	1	1	-								
	ΔT	27	28	30	-	26	27	30	-	25	26	29	-	25	26	28	-	24	24	27	-	22	23	25	-								
70	KW	4.273	4.356	4.483	-	4.576	4.668	4.807	-	4.844	4.943	5.093	-	5.08	5.185	5.345	-	5.281	5.392	5.56	-	5.455	5.57	5.745	-								
	Amps	7.221	7.341	7.51	-	7.627	7.758	7.942	-	8.097	8.241	8.442	-	8.504	8.658	8.874	-	8.91	9.075	9.306	-	9.31	9.486	9.732	-								
	Hi PR	154.9	166.6	176	-	173.8	187	197.5	-	197.6	212.7	224.6	-	225.1	242.2	255.8	-	253.2	272.5	287.8	-	279.8	301.1	317.9	-								
	Lo PR	62.18	66.15	72.22	-	65.7	69.89	76.3	-	68.28	72.64	79.3	-	71.72	76.30	83.3	-	75.16	79.97	87.3	-	77.75	82.71	90.3	-								
	MBh	49.61	51.42	56.34	-	48.46	50.23	55.03	-	47.31	49.03	53.72	-	46.15	47.84	52.41	-	43.84	45.44	49.79	-	40.61	42.1	46.12	-								
	S/T	1	1	1	-	1	1	1	-	1	1	1	-	1	1	1	-	1	1	1	-	1	1	1	-								
	ΔT	28	29	32	-	28	29	31	-	27	28	31	-	26	27	30	-	25	26	28	-	23	24	26	-								
1619	KW	4.179	4.26	4.383	-	4.473	4.562	4.697	-	4.733	4.829	4.974	-	4.962	5.064	5.219	-	5.157	5.264	5.427	-	5.325	5.437	5.606	-								
	Amps	7.085	7.202	7.365	-	7.479	7.607	7.784	-	7.935	8.075	8.27	-	8.329	8.479	8.689	-	8.724	8.884	9.108	-	9.112	9.282	9.521	-								
	Hi PR	150.2	161.7	170.7	-	168.6	181.4	191.5	-	191.7	206.3	217.8	-	218.3	235.0	248.1	-	245.6	264.3	279.1	-	271.4	292.1	308.4	-								
	Lo PR	60.32	64.17	70.05	-	63.73	67.8	74.01	-	66.23	70.46	76.92	-	69.57	74.01	80.80	-	72.91	77.57	84.68	-	75.41	80.23	87.59	-								

	MBh	56.3	57.97	62.75	67.34	54.99	56.62	61.29	65.78	53.68	55.27	59.83	64.21	52.38	53.93	58.37	62.65	49.76	51.23	55.45	59.51	46.09	47.45	51.37	55.13
	S/T	1	1	1	1	1	1	1	1	1	1	1	1	1	1	1	1	1	1	1	1	1	1	1	1
	ΔT	25	26	28	30	24	25	27	29	24	24	26	28	23	24	26	28	22	23	24	26	20	21	23	24
2081	KW	4.336	4.422	4.551	4.688	4.646	4.739	4.882	5.031	4.919	5.02	5.173	5.334	5.16	5.268	5.431	5.602	5.365	5.478	5.649	5.83	5.542	5.66	5.838	6.026
	Amps	7.313	7.435	7.607	7.808	7.727	7.861	8.048	8.267	8.207	8.353	8.558	8.799	8.621	8.779	8.999	9.258	9.036	9.204	9.44	9.717	9.444	9.624	9.875	10.17
	Hi PR	158	170	179.6	187.3	177.3	190.8	201.5	210.1	201.6	217	229.1	239	229.7	247.1	261.0	272.2	258.4	278	293.6	306.2	285.5	307.2	324.4	338.3
	Lo PR	63.45	67.5	73.69	78.48	67.03	71.31	77.85	82.91	69.67	74.12	80.91	86.17	73.18	77.85	84.99	90.52	76.69	81.59	89.07	94.86	79.32	84.39	92.13	98.12
	MBh	54.66	56.28	60.92	65.38	53.39	54.97	59.5	63.86	52.12	53.66	58.09	62.34	50.85	52.36	56.67	60.82	48.31	49.74	53.84	57.78	44.75	46.07	49.87	53.52
	S/T	1	1	1	1	1	1	1	1	1	1	1	1	1	1	1	1	1	1	1	1	1	1	1	1
	ΔT	27	28	30	32	27	27	30	32	26	27	29	31	25	26	28	30	24	25	27	29	22	23	25	27
1850	KW	4.305	4.389	4.517	4.653	4.611	4.704	4.844	4.993	4.882	4.982	5.133	5.293	5.121	5.227	5.388	5.558	5.323	5.435	5.605	5.783	5.499	5.615	5.792	5.978
	Amps	7.267	7.389	7.559	7.758	7.678	7.81	7.995	8.212	8.152	8.297	8.5	8.738	8.563	8.719	8.937	9.193	8.973	9.14	9.374	9.647	9.378	9.555	9.804	10.1
	Hi PR	156.4	168.4	177.8	185.4	175.5	188.9	199.5	208.1	199.6	214.8	226.9	236.6	227.4	244.7	258.4	269.5	255.8	275.3	290.7	303.2	282.6	304.2	321.2	335
	Lo PR	62.82	66.83	72.96	77.7	66.37	70.61	77.08	82.09	68.98	73.38	80.11	85.32	72.45	77.08	84.15	89.62	75.93	80.78	88.19	93.92	78.54	83.56	91.22	97.15
	MBh	50.45	51.95	56.23	60.35	49.28	50.74	54.92	58.94	48.11	49.53	53.61	57.54	46.93	48.32	52.31	56.14	44.59	45.91	49.69	53.33	41.3	42.52	46.03	49.4
	S/T	1	1	1	1	1	1	1	1	1	1	1	1	1	1	1	1	1	1	1	1	1	1	1	1
	ΔT	29	30	32	34	28	29	31	33	27	28	30	33	27	27	30	32	25	26	28	30	23	24	26	28
1619	KW	4.21	4.292	4.416	4.547	4.507	4.597	4.733	4.877	4.77	4.866	5.014	5.168	5.001	5.104	5.261	5.425	5.198	5.306	5.471	5.644	5.368	5.481	5.652	5.832
	Amps	7.13	7.248	7.413	7.606	7.528	7.657	7.836	8.047	7.989	8.129	8.326	8.557	8.387	8.538	8.750	8.998	8.785	8.947	9.173	9.439	9.177	9.35	9.591	9.873
	Hi PR	151.7	163.3	172.4	179.9	170.3	183.2	193.5	201.8	193.7	208.4	220.1	229.5	220.6	237.4	250.6	261.4	248.1	267	282	294.1	274.2	295	311.5	324.9
	Lo PR	60.93	64.82	70.77	75.37	64.38	68.49	74.77	79.63	66.91	71.18	77.71	82.76	70.28	74.77	81.63	86.93	73.65	78.36	85.54	91.1	76.18	81.05	88.48	94.23

Shaded area reflects ACCA (TVA) conditions IDB: Entering Indoor Dry Bulb Temperature kW = Total system power Amps = outdoor unit amps (comp. +fan)
 High and low pressures are measured at the liquid and suction service valves.

EXPANDED COOLING DATA — GPH1360M24AA (CONT.)

IDB	Airflow	Outdoor Ambient Temperature																													
		65					75					85					95					105					115				
		59	63	67	71	75	59	63	67	71	75	59	63	67	71	75	59	63	67	71	75	59	63	67	71	75	59	63	67	71	75
2081	MBh	57.3	58.56	62.56	66.88	55.97	57.19	61.1	65.32	54.64	55.83	59.65	63.77	53.31	54.47	58.20	62.21	50.64	51.75	55.29	59.1	46.91	47.93	51.21	54.75						
	S/T	0.927	0.869	0.707	0.529	0.96	0.901	0.733	0.548	1	0.924	0.752	0.562	1	0.953	0.776	0.58	1	0.805	0.602	1	1	0.812	0.607							
	ΔT	23	22	19	15	23	22	19	15	24	22	19	15	23	22	19	16	22	22	19	15	20	21	18	14						
	KW	4.124	4.214	4.35	4.494	4.45	4.548	4.698	4.855	4.737	4.844	5.005	5.175	4.991	5.104	5.276	5.456	5.207	5.326	5.506	5.696	5.393	5.517	5.705	5.902						
	Amps	15.98	16.23	16.58	16.99	16.83	17.1	17.48	17.93	17.81	18.11	18.53	19.02	18.65	18.98	19.43	19.96	19.5	19.85	20.33	20.9	20.34	20.71	21.22	21.82						
	Hi PR	169.4	182.3	192.5	200.8	190.1	204.5	216	225.3	216.2	232.6	245.6	256.2	246.2	264.9	279.8	291.8	277	298.1	314.7	328.3	306	329.3	347.8	362.7						
	Lo PR	63.71	67.78	73.99	78.8	67.31	71.61	78.18	83.26	69.95	74.42	81.25	86.53	73.48	78.18	85.35	90.89	77.01	81.93	89.44	95.26	79.65	84.74	92.51	98.53						
	MBh	55.64	56.85	60.74	64.93	54.34	55.53	59.33	63.42	53.05	54.21	57.91	61.91	51.75	52.88	56.5	60.4	49.17	50.24	53.68	57.38	45.54	46.54	49.72	53.15						
	S/T	0.884	0.829	0.675	0.504	0.916	0.859	0.699	0.523	0.939	0.881	0.717	0.536	0.969	0.909	0.74	0.553	1	0.944	0.768	0.574	1	0.952	0.774	0.579						
	ΔT	24	23	20	16	24	23	20	16	24	23	20	16	24	23	20	16	24	23	20	16	22	21	19	15						
80	KW	4.091	4.18	4.315	4.457	4.413	4.511	4.659	4.815	4.698	4.803	4.963	5.131	4.949	5.061	5.231	5.41	5.163	5.28	5.459	5.647	5.347	5.47	5.656	5.851						
	Amps	15.88	16.13	16.48	16.89	16.72	16.99	17.37	17.82	17.69	17.99	18.41	18.89	18.53	18.85	19.3	19.82	19.37	19.72	20.19	20.75	20.2	20.56	21.07	21.67						
	Hi PR	167.7	180.5	190.6	198.8	188.2	202.5	213.8	223	214	230.3	243.2	253.7	243.8	262.3	277	288.9	274.2	295.1	311.6	325	303	326.1	344.3	359.1						
	Lo PR	63.08	67.11	73.26	78.02	66.64	70.9	77.4	82.43	69.26	73.69	80.44	85.67	72.75	77.40	84.5	89.99	76.25	81.12	88.56	94.31	78.87	83.9	91.6	97.55						
	MBh	51.35	52.47	56.06	59.93	50.16	51.25	54.76	58.54	48.96	50.03	53.45	57.14	47.77	48.81	52.15	55.75	45.38	46.37	49.54	52.96	42.04	42.95	45.89	49.06						
	S/T	0.852	0.799	0.65	0.486	0.883	0.828	0.674	0.504	0.906	0.849	0.691	0.517	0.935	0.877	0.714	0.533	0.97	0.91	0.741	0.554	0.978	0.918	0.747	0.558						
	ΔT	24	23	20	16	24	23	20	16	25	24	21	16	25	24	21	16	24	23	20	16	23	22	19	15						
	KW	3.991	4.077	4.208	4.346	4.304	4.398	4.542	4.693	4.58	4.682	4.837	5	4.824	4.932	5.097	5.27	5.031	5.145	5.318	5.5	5.21	5.328	5.509	5.699						
	Amps	15.6	15.84	16.18	16.58	16.42	16.68	17.05	17.48	17.36	17.65	18.05	18.52	18.17	18.48	18.92	19.42	18.99	19.32	19.78	20.33	19.79	20.14	20.64	21.22						
	Hi PR	162.7	175.1	184.9	192.8	182.5	196.4	207.4	216.3	207.6	223.4	235.9	246.1	236.4	254.4	268.7	280.2	266	286.3	302.3	315.3	293.9	316.3	334	348.3						
Lo PR	61.19	65.09	71.06	75.68	64.64	68.77	75.08	79.96	67.18	71.48	78.03	83.1	70.57	75.08	81.97	87.29	73.96	78.68	85.9	91.48	76.5	81.39	88.85	94.63							

2081	MBh	58.31	59.43	62.25	66.41	56.95	58.05	60.8	64.86	55.59	56.67	59.35	63.32	54.24	55.29	57.90	61.77	51.53	52.52	55.01	58.69	47.73	48.65	50.96	54.36
	S/T	0.971	0.937	0.846	0.686	1	0.971	0.877	0.711	1	0.996	0.899	0.729	1	1	0.928	0.753	1	1	0.963	0.781	1	1	0.971	0.788
	ΔT	24	24	23	20	24	24	23	20	24	24	23	20	23	24	23	20	22	23	23	20	21	21	21	18
	KW	4.158	4.248	4.386	4.531	4.487	4.586	4.737	4.896	4.777	4.884	5.047	5.219	5.034	5.148	5.321	5.503	5.251	5.371	5.553	5.745	5.439	5.564	5.754	5.954
	Amps	16.07	16.32	16.68	17.1	16.93	17.2	17.59	18.04	17.92	18.22	18.65	19.14	18.78	19.10	19.56	20.09	19.63	19.98	20.47	21.04	20.48	20.85	21.37	21.97
	Hi PR	171.1	184.1	194.4	202.8	192	206.6	218.1	227.5	218.3	234.9	248.1	258.8	248.7	267.6	282.6	294.7	279.7	301	317.9	331.6	309.1	332.6	351.2	366.3
	Lo PR	64.35	68.46	74.73	79.59	67.98	72.33	78.96	84.09	70.65	75.17	82.06	87.39	74.22	78.96	86.20	91.8	77.78	82.75	90.34	96.21	80.45	85.59	93.44	99.51
	MBh	56.61	57.7	60.43	64.47	55.29	56.36	59.03	62.97	53.97	55.02	57.62	61.48	52.66	53.68	56.22	59.98	50.03	50.99	53.41	56.98	46.34	47.24	49.47	52.78
	S/T	0.926	0.894	0.807	0.655	0.96	0.926	0.836	0.678	0.985	0.95	0.857	0.696	1	0.981	0.885	0.718	1	1	0.919	0.745	1	1	0.926	0.751
	ΔT	25	25	24	20	26	25	24	21	26	25	24	21	25	25	24	21	24	25	24	21	22	23	22	19
85	KW	4.124	4.214	4.35	4.494	4.45	4.548	4.698	4.855	4.737	4.844	5.005	5.175	4.991	5.104	5.276	5.456	5.207	5.326	5.506	5.696	5.393	5.517	5.705	5.902
	Amps	15.98	16.23	16.58	16.99	16.83	17.1	17.48	17.93	17.81	18.11	18.53	19.02	18.65	18.98	19.43	19.96	19.5	19.85	20.33	20.9	20.34	20.71	21.22	21.82
	Hi PR	169.4	182.3	192.5	200.8	190.1	204.5	216	225.3	216.2	232.6	245.6	256.2	246.2	264.9	279.8	291.8	277	298.1	314.7	328.3	306	329.3	347.8	362.7
	Lo PR	63.71	67.78	73.99	78.8	67.31	71.61	78.18	83.26	69.95	74.42	81.25	86.53	73.48	78.18	85.35	90.89	77.01	81.93	89.44	95.26	79.65	84.74	92.51	98.53
	MBh	52.25	53.26	55.78	59.51	51.03	52.02	54.48	58.13	49.82	50.78	53.19	56.74	48.6	49.54	51.89	55.36	46.17	47.07	49.29	52.59	42.77	43.6	45.66	48.71
	S/T	0.893	0.862	0.778	0.631	0.926	0.893	0.806	0.654	0.949	0.916	0.827	0.671	0.98	0.946	0.853	0.692	1	0.981	0.886	0.719	1	0.99	0.893	0.725
	ΔT	26	25	24	21	26	26	24	21	26	26	24	21	26	26	24	21	26	26	24	21	26	24	23	20
	KW	4.023	4.11	4.243	4.382	4.339	4.435	4.58	4.732	4.618	4.721	4.878	5.042	4.864	4.974	5.140	5.315	5.074	5.189	5.364	5.548	5.254	5.374	5.556	5.748
	Amps	15.69	15.94	16.28	16.68	16.52	16.78	17.15	17.59	17.47	17.76	18.17	18.64	18.29	18.60	19.04	19.55	19.11	19.45	19.92	20.46	19.92	20.28	20.78	21.36
	Hi PR	164.3	176.8	186.7	194.7	184.4	198.4	209.5	218.5	209.7	225.6	238.3	248.5	238.8	257.0	271.4	283	268.7	289.1	305.3	318.4	296.8	319.4	337.3	351.8
Lo PR	61.8	65.75	71.77	76.44	65.29	69.46	75.83	80.76	67.86	72.19	78.81	83.93	71.28	75.83	82.78	88.17	74.7	79.47	86.76	92.4	77.26	82.2	89.74	95.57	

Shaded area reflects ARI conditions IDB: Entering Indoor Dry Bulb Temperature kW = Total system power Amps = outdoor unit amps (comp. +fan)
 High and low pressures are measured at the liquid and suction service valves.

EXPANDED HEATING DATA

GPH1336M23A*

	Outdoor Ambient Temperature																	
	65	60	55	50	47	45	40	35	30	25	20	17	15	10	5	0	-5	-10
MBh	43.0	40.7	38.3	35.8	34.2	33.1	30.8	28.4	23.2	21.4	19.7	18.6	17.9	16.1	14.2	12.4	10.6	8.7
ΔT	33.2	31.4	29.6	27.6	26.4	25.6	23.8	21.9	17.9	16.5	15.2	14.4	13.8	12.4	11.0	9.6	8.2	6.7
kW	3.15	3.09	3.04	2.98	2.95	2.92	2.87	2.81	2.74	2.68	2.62	2.59	2.57	2.51	2.46	2.40	2.34	2.29
Amps	12.3	11.5	10.9	10.4	10.1	9.9	9.5	9.1	8.8	8.5	8.2	8.1	8.0	7.7	7.4	7.1	6.7	6.2
COP	3.99	3.85	3.69	3.52	3.40	3.32	3.14	2.96	2.48	2.34	2.20	2.10	2.04	1.87	1.70	1.51	1.32	1.11
EER	13.6	13.2	12.6	12.0	11.6	11.3	10.7	10.1	8.5	8.0	7.5	7.2	7.0	6.4	5.8	5.2	4.5	3.8
Hi PR	259	248	239	228	223	219	210	202	193	185	177	173	170	163	157	151	145	140
Lo PR	81	75	71	65	61	59	54	48	43	39	34	32	31	26	22	19	16	13

Calculations are based on nominal CFM and 70°F indoor dry bulb.

High pressure is measured at the suction service valve (the larger valve).

Low pressure is measured at the gauge port connection.

Amps = Outdoor unit amps (comp.+fan)

kW = Total system power

GPH1348M23A*

	Outdoor Ambient Temperature																	
	65	60	55	50	47	45	40	35	30	25	20	17	15	10	5	0	-5	-10
MBh	56.6	53.6	50.4	47.1	45.0	43.6	40.5	37.4	31.2	28.8	26.5	25.0	24.1	21.6	19.2	16.7	14.3	11.7
ΔT	30.4	28.7	27.1	25.3	24.2	23.4	21.7	20.0	16.7	15.4	14.2	13.4	12.9	11.6	10.3	9.0	7.6	6.3
kW	4.01	3.94	3.87	3.80	3.76	3.73	3.66	3.59	3.51	3.44	3.37	3.33	3.30	3.23	3.16	3.10	3.03	2.96
Amps	17.5	16.6	15.8	15.2	14.8	14.6	14.1	13.6	13.2	12.8	12.5	12.3	12.2	11.8	11.3	11.0	10.5	9.9
COP	4.13	3.98	3.81	3.63	3.50	3.42	3.24	3.04	2.60	2.45	2.30	2.20	2.13	1.96	1.77	1.58	1.38	1.15
EER	14.1	13.6	13.0	12.4	12.0	11.7	11.1	10.4	8.9	8.4	7.9	7.5	7.3	6.7	6.1	5.4	4.7	3.9
Hi PR	241	231	222	212	207	203	195	187	179	171	165	161	158	152	146	140	135	130
Lo PR	78	72	68	62	59	56	52	46	42	37	33	30	29	25	21	18	16	12

Calculations are based on nominal CFM and 70°F indoor dry bulb.

High pressure is measured at the suction service valve (the larger valve).

Low pressure is measured at the gauge port connection.

Amps = Outdoor unit amps (comp.+fan)

kW = Total system power

GPH1360M23A*

	Outdoor Ambient Temperature																	
	65	60	55	50	47	45	40	35	30	25	20	17	15	10	5	0	-5	-10
MBh	69.1	65.5	61.6	57.6	55.0	53.3	49.5	45.7	38.6	35.7	32.8	31.0	29.9	26.8	23.7	20.7	17.7	14.5
ΔT	34.6	32.8	30.8	28.8	27.5	26.7	24.8	22.8	19.3	17.8	16.4	15.5	14.9	13.4	11.9	10.4	8.8	7.2
kW	5.06	4.97	4.88	4.78	4.73	4.69	4.60	4.51	4.58	4.48	4.38	4.33	4.29	4.19	4.10	4.00	3.90	3.81
Amps	22.7	21.4	20.4	19.5	19.0	18.7	18.0	17.3	16.8	16.3	15.8	15.6	15.4	14.9	14.3	13.8	13.1	12.4
COP	4.00	3.85	3.70	3.52	3.40	3.32	3.15	2.96	2.47	2.33	2.19	2.10	2.04	1.87	1.70	1.51	1.33	1.11
EER	13.7	13.2	12.6	12.0	11.6	11.4	10.8	10.1	8.4	8.0	7.5	7.2	7.0	6.4	5.8	5.2	4.5	3.8
Hi PR	263	252	242	231	226	222	213	205	196	187	180	175	172	166	159	153	147	142
Lo PR	74	68	64	59	56	53	49	44	39	35	31	29	28	23	20	17	15	12

Calculations are based on nominal CFM and 70°F indoor dry bulb.

High pressure is measured at the suction service valve (the larger valve).

Low pressure is measured at the gauge port connection.

Amps = Outdoor unit amps (comp.+fan)

kW = Total system power

EXPANDED HEATING DATA (CONT.)

GPH1336M24A*

	Outdoor Ambient Temperature																	
	65	60	55	50	47	45	40	35	30	25	20	17	15	10	5	0	-5	-10
MBh	43.0	40.7	38.3	35.8	34.2	33.1	30.8	28.4	23.2	21.4	19.7	18.6	17.9	16.1	14.2	12.4	10.6	8.7
ΔT	33.2	31.4	29.6	27.6	26.4	25.6	23.8	21.9	17.9	16.5	15.2	14.4	13.8	12.4	11.0	9.6	8.2	6.7
kW	3.16	3.10	3.04	2.98	2.94	2.92	2.86	2.80	2.75	2.69	2.63	2.60	2.57	2.51	2.45	2.40	2.34	2.28
Amps	6.3	5.9	5.6	5.4	5.2	5.1	4.9	4.7	4.6	4.4	4.2	4.2	4.1	4.0	3.8	3.6	3.4	3.2
COP	3.98	3.84	3.69	3.52	3.40	3.32	3.15	2.97	2.47	2.33	2.19	2.10	2.04	1.87	1.70	1.52	1.33	1.12
EER	13.6	13.1	12.6	12.0	11.6	11.4	10.8	10.1	8.4	8.0	7.5	7.2	7.0	6.4	5.8	5.2	4.5	3.8
Hi PR	263	252	242	231	226	222	213	205	196	187	180	175	172	166	159	153	147	142
Lo PR	79	73	69	63	59	57	53	47	42	38	33	31	30	25	22	18	16	13

Calculations are based on nominal CFM and 70°F indoor dry bulb.

High pressure is measured at the suction service valve (the larger valve).

Low pressure is measured at the gauge port connection.

Amps = Outdoor unit amps (comp.+fan)

kW = Total system power

GPH1348M24A*

	Outdoor Ambient Temperature																	
	65	60	55	50	47	45	40	35	30	25	20	17	15	10	5	0	-5	-10
MBh	56.57	53.55	50.4	47.12	45.0	43.61	40.5	37.35	31.15	28.75	26.48	25	24.08	21.6	19.15	16.7	14.25	11.68
ΔT	30.36	28.74	27.05	25.29	24.15	23.41	21.74	20.05	16.72	15.43	14.21	13.42	12.92	11.59	10.28	8.964	7.649	6.267
kW	4.023	3.951	3.879	3.807	3.77	3.736	3.667	3.595	3.685	3.608	3.534	3.489	3.459	3.382	3.308	3.233	3.156	3.082
Amps	9.047	8.528	8.11	7.747	7.54	7.434	7.127	6.865	6.658	6.451	6.24	6.139	6.083	5.877	5.62	5.408	5.151	4.839
COP	4.115	3.967	3.802	3.621	3.497	3.416	3.232	3.041	2.474	2.332	2.193	2.097	2.037	1.869	1.694	1.512	1.321	1.109
EER	14.06	13.55	12.99	12.37	11.95	11.67	11.05	10.39	8.453	7.968	7.492	7.165	6.96	6.386	5.789	5.165	4.515	3.788
Hi PR	168.5	161.5	155.3	148.5	145	142.2	136.7	131.2	125.7	120.1	115.3	112.5	110.5	106.3	102.2	98.02	94.54	91.21
Lo PR	79.62	73.86	69.24	63.48	60	57.72	53.1	47.28	42.66	38.1	33.48	31.14	30	25.38	21.9	18.48	16.14	12.66

Calculations are based on nominal CFM and 70°F indoor dry bulb.

High pressure is measured at the suction service valve (the larger valve).

Low pressure is measured at the gauge port connection.

Amps = Outdoor unit amps (comp.+fan)

kW = Total system power

GPH1360M24A*

	Outdoor Ambient Temperature																	
	65	60	55	50	47	45	40	35	30	25	20	17	15	10	5	0	-5	-10
MBh	69.14	65.45	61.6	57.59	55.0	53.3	49.5	45.65	38.63	35.65	32.83	31	29.85	26.78	23.75	20.71	17.67	14.48
ΔT	34.6	32.76	30.83	28.82	27.53	26.67	24.77	22.85	19.33	17.84	16.43	15.52	14.94	13.41	11.88	10.36	8.844	7.246
kW	5.07	4.977	4.883	4.79	4.74	4.696	4.607	4.513	4.571	4.473	4.377	4.32	4.282	4.183	4.088	3.993	3.894	3.799
Amps	9.845	9.278	8.822	8.426	8.2	8.085	7.749	7.463	7.238	7.012	6.781	6.671	6.611	6.385	6.105	5.874	5.593	5.252
COP	3.99	3.849	3.692	3.518	3.399	3.321	3.145	2.96	2.473	2.333	2.195	2.1	2.04	1.874	1.7	1.518	1.328	1.115
EER	13.64	13.15	12.61	12.02	11.61	11.35	10.75	10.11	8.45	7.971	7.5	7.176	6.972	6.403	5.809	5.187	4.538	3.811
Hi PR	248.7	238.4	229.2	219.1	214	209.9	201.8	193.7	185.5	177.2	170.1	166.1	163.1	156.9	150.9	144.7	139.5	134.6
Lo PR	72.99	67.71	63.47	58.19	55	52.91	48.68	43.34	39.11	34.93	30.69	28.55	27.5	23.27	20.08	16.94	14.8	11.61

Calculations are based on nominal CFM and 70°F indoor dry bulb.

High pressure is measured at the suction service valve (the larger valve).

Low pressure is measured at the gauge port connection.

Amps = Outdoor unit amps (comp.+fan)

kW = Total system power

HEAT KIT ELECTRICAL DATA (BLOWER ONLY, HEAT MODE)

Model & Heat Kit Usage	Circuit #1		Circuit #2		Actual kW / BTU@ 240V
	MCA ¹	MOD ²	MCA ¹	MOD ²	
GPH1336M23AA	1.9 / 1.9	--	--	--	--
^HKR3-15*	39 / 45	60 / 60	--	--	15.0 / 55,100
^HKR3-20*	51 / 55	60 / 60	--	--	19.5 / 66,500
GPH1348M23AA	5.8 / 5.8	--	--	--	--
^HKR3-15*	39 / 45	60 / 60	--	--	15.0 / 55,100
^HKR3-20*	51 / 55	60 / 60	--	--	19.5 / 66,500
GPH1360M23AA	7.6 / 7.6	--	--	--	--
^HKR3-15*	39 / 45	60 / 60	--	--	15.0 / 55,100
^HKR3-20*	51 / 55	60 / 60	--	--	19.5 / 66,500

Model & Heat Kit Usage	Circuit #1		Circuit #2		Actual kW / BTU@ 460V
	MCA ¹	MOD ²	MCA ¹	MOD ²	
GPH1336M24AA	1.2 / 1.2	--	--	--	--
^HKR4-15*	23	30	--	--	15.0 / 55,100
^HKR4-20*	30	30	--	--	19.5 / 66,500
GPH1348M24AA	2.9 / 2.9	--	--	--	--
^HKR4-15*	23	30	--	--	15.0 / 55,100
^HKR4-20*	30	30	--	--	19.5 / 66,500
GPH1360M24AA	3.8 / 3.8	--	--	--	--
^HKR4-15*	23	30	--	--	15.0 / 55,100
^HKR4-20*	30	30	--	--	19.5 / 66,500

¹ Minimum Circuit Ampacity @ 208 / 240 V

² Maximum Overcurrent Protection device @ 208 / 240 V

³ Minimum Circuit Ampacity @ 460 V

⁴ Maximum Overcurrent Protection device @ 460 V

* Revision level that may or may not be designated

^ Heat Kit requires three-phase power supply

DIMENSIONS

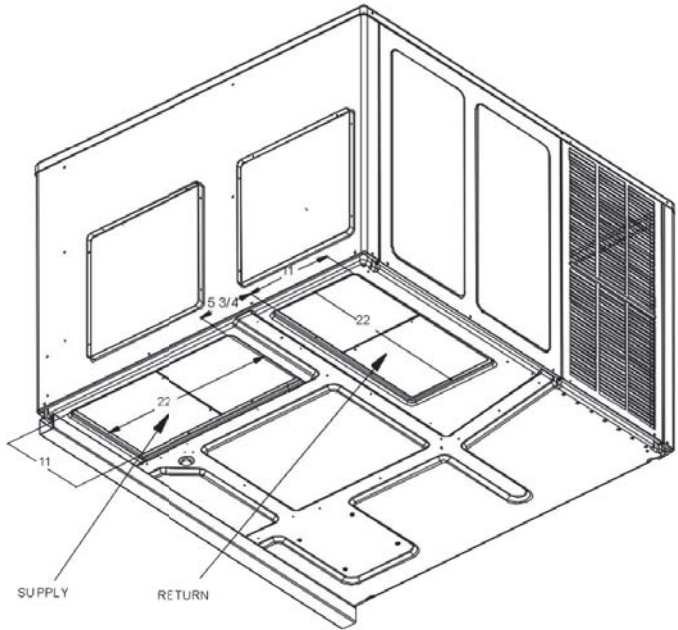
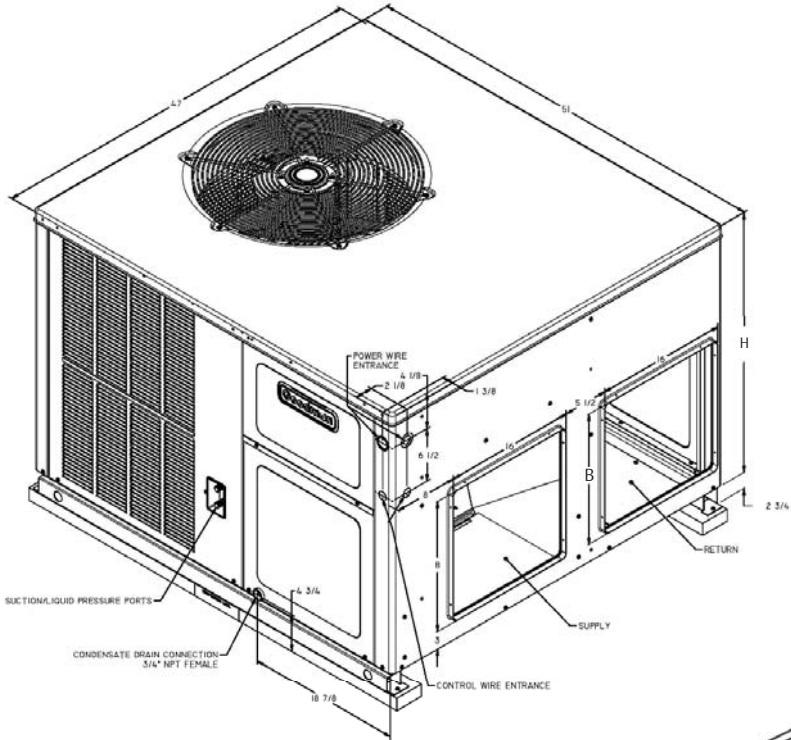

DIMENSIONS

Model	Medium	Large	H x D x W	B	H
GPH1336M23AA	X		34 ³ / ₄ " x 51" x 47"	16"	32 ¹ / ₂ "
GPH1336M24AA	X		34 ³ / ₄ " x 51" x 47"	16"	32 ¹ / ₂ "
GPH1348M23AA		X	42 ³ / ₄ " x 51" x 47"	18"	40"
GPH1348M24AA		X	42 ³ / ₄ " x 51" x 47"	18"	40"
GPH1360M23AA		X	42 ³ / ₄ " x 51" x 47"	18"	40"
GPH1360M24AA		X	42 ³ / ₄ " x 51" x 47"	18"	40"

FILTERS

Model	Dimensions	Qty.
GPH13MFR102 (for medium models)	16" x 25" x 2"	1
GPH13MFR103 (for large models)	20" x 25" x 2"	2

WIRING DIAGRAM — GPH1336M23A*

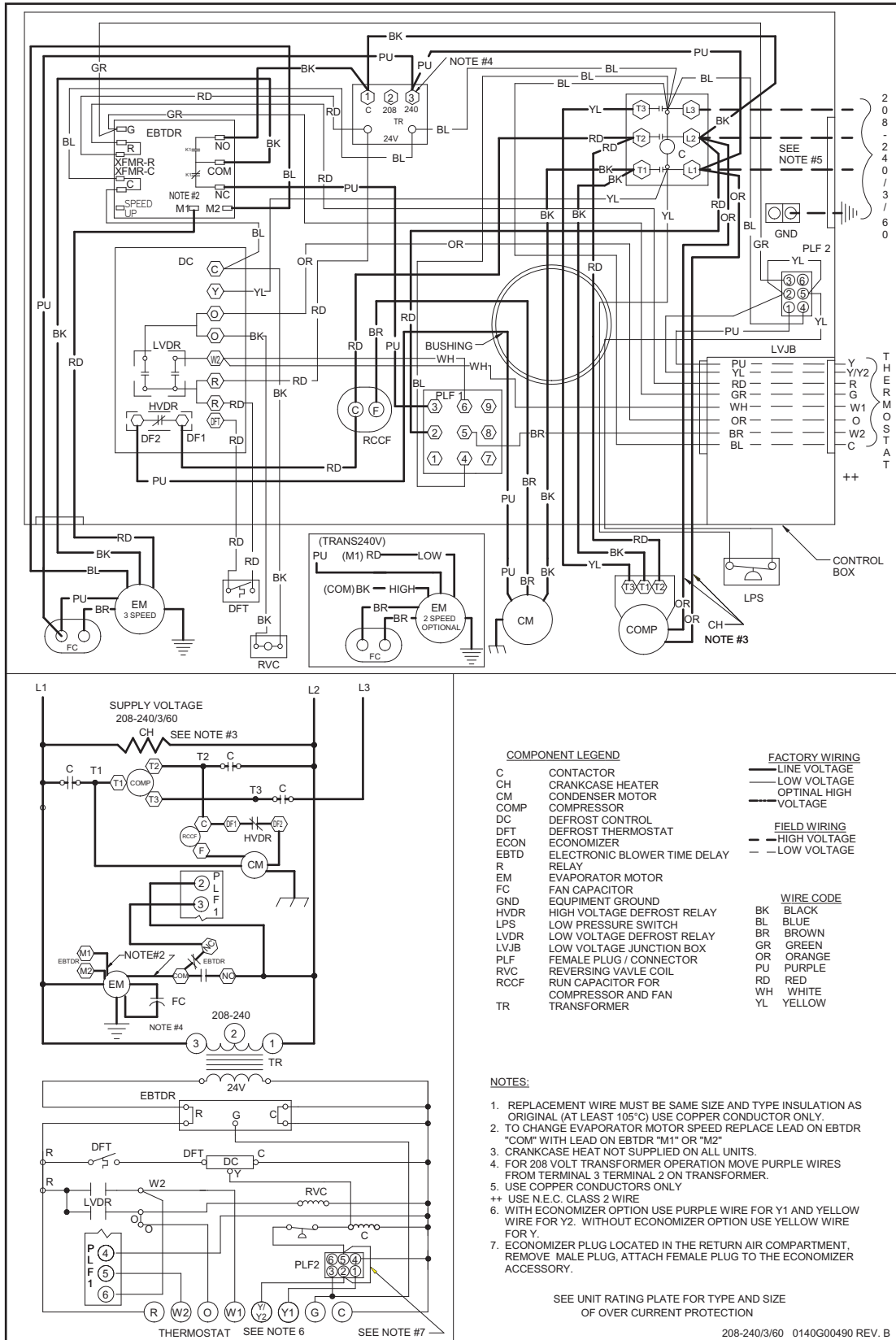

High Voltage: Disconnect all power before servicing or installing this unit. Multiple power sources may be present. Failure to do so may cause property damage, personal injury, or death.

WARNING

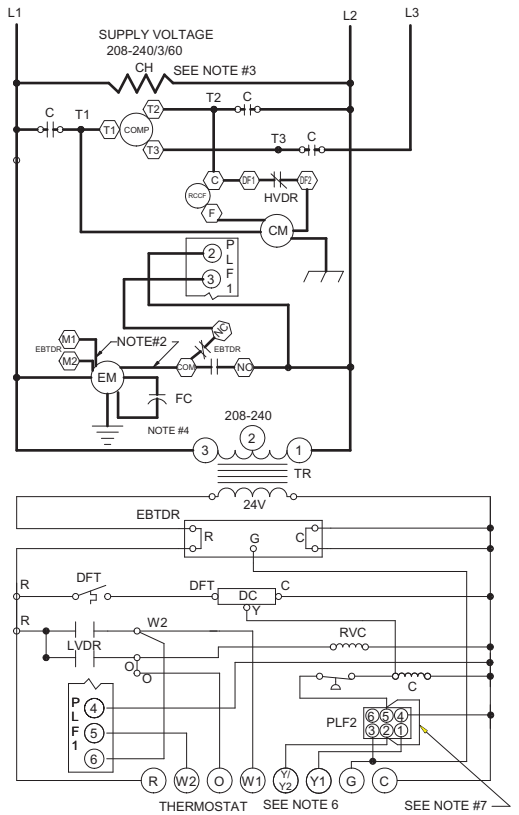

COMPONENT LEGEND

C	CONTACTOR	FACTORY WIRING
CH	CRANKCASE HEATER	— LINE VOLTAGE
CM	CONDENSER MOTOR	— LOW VOLTAGE
COMP	COMPRESSOR	— OPTIMAL HIGH VOLTAGE
DC	DEFROST CONTROL	— FIELD WIRING
DFT	DEFROST THERMOSTAT	— HIGH VOLTAGE
ECON	ECONOMIZER	— LOW VOLTAGE
EBTD	ELECTRONIC BLOWER TIME DELAY	
R	RELAY	
EM	EVAPORATOR MOTOR	
FC	FAN CAPACITOR	
GND	EQUIPMENT GROUND	
HVDR	HIGH VOLTAGE DEFROST RELAY	
LPS	LOW PRESSURE SWITCH	
LVD	LOW VOLTAGE DEFROST RELAY	
LVJB	LOW VOLTAGE JUNCTION BOX	
PLF	FEMALE PLUG / CONNECTOR	
RVC	REVERSING VALVE COIL	
RCCF	RUN CAPACITOR FOR COMPRESSOR AND FAN	
TR	TRANSFORMER	

WIRE CODE

BK	BLACK
BL	BLUE
BR	BROWN
GR	GREEN
OR	ORANGE
PU	PURPLE
RD	RED
WH	WHITE
YL	YELLOW

- NOTES:**
1. REPLACEMENT WIRE MUST BE SAME SIZE AND TYPE INSULATION AS ORIGINAL (AT LEAST 105°C) USE COPPER CONDUCTOR ONLY.
 2. TO CHANGE EVAPORATOR MOTOR SPEED REPLACE LEAD ON EBTD "COM" WITH LEAD ON EBTD "M1" OR "M2"
 3. CRANKCASE HEAT NOT SUPPLIED ON ALL UNITS.
 4. FOR 208 VOLT TRANSFORMER OPERATION MOVE PURPLE WIRES FROM TERMINAL 3 TERMINAL 2 ON TRANSFORMER.
 5. USE COPPER CONDUCTORS ONLY
 6. WITH ECONOMIZER OPTION USE PURPLE WIRE FOR Y1 AND YELLOW WIRE FOR Y2. WITHOUT ECONOMIZER OPTION USE YELLOW WIRE FOR Y.
 7. ECONOMIZER PLUG LOCATED IN THE RETURN AIR COMPARTMENT. REMOVE MALE PLUG, ATTACH FEMALE PLUG TO THE ECONOMIZER ACCESSORY.

SEE UNIT RATING PLATE FOR TYPE AND SIZE OF OVER CURRENT PROTECTION
 208-240/3/60 0140G00490 REV. B

Wiring is subject to change. Always refer to the wiring diagram on the unit for the most up-to-date wiring schematic.

WIRING DIAGRAM — GPH1348-60M23A*

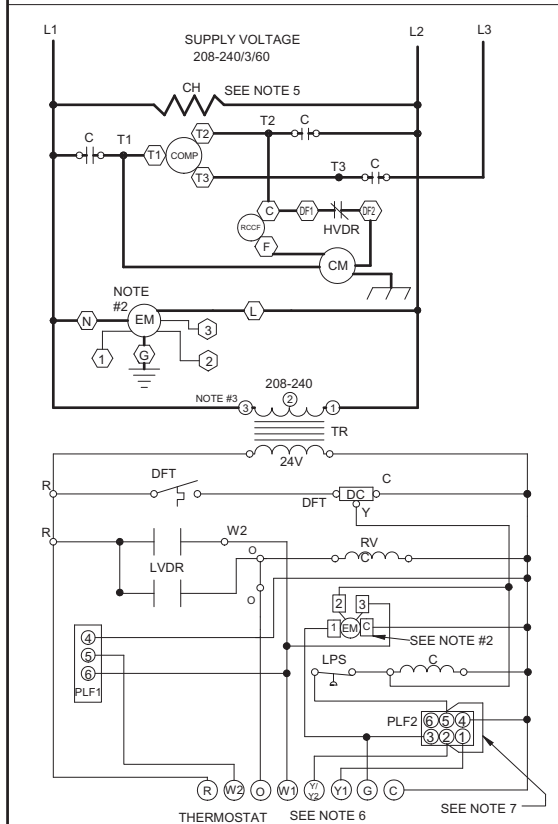
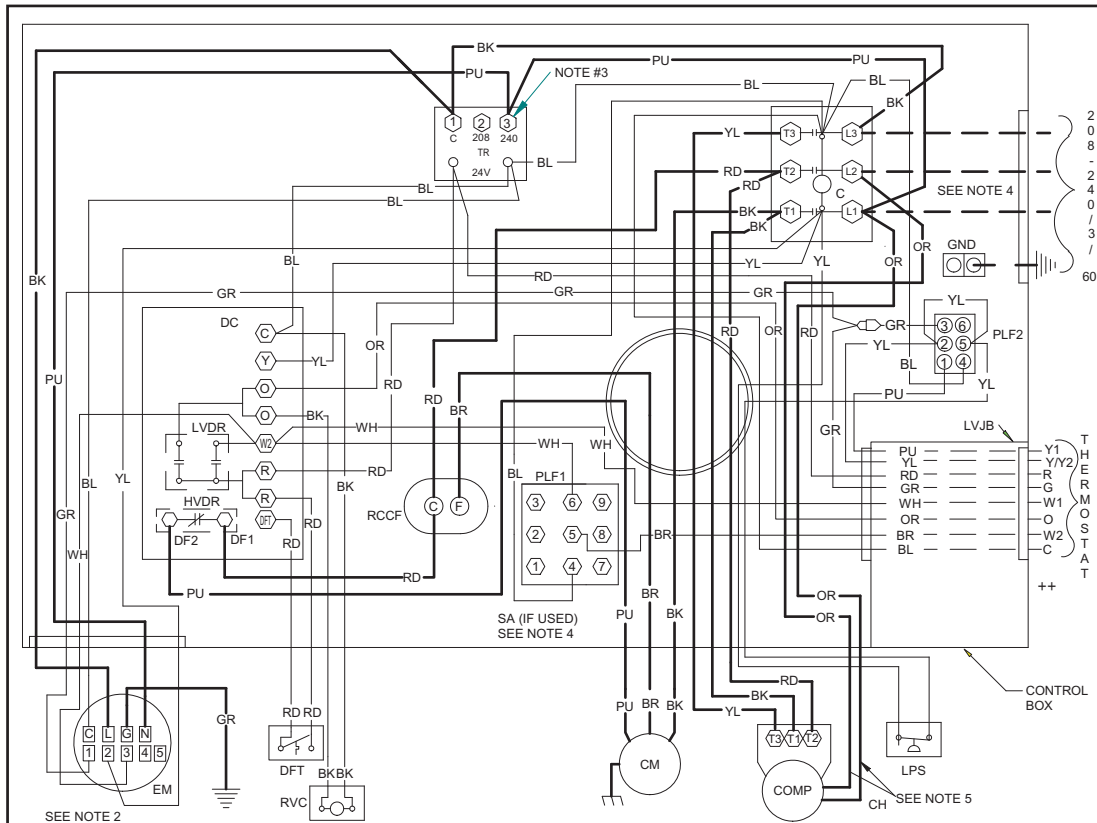

COMPONENT LEGEND

C	CONTACTOR	FACTORY WIRING	— LINE VOLTAGE
CH	CRANKCASE HEATER	— LOW VOLTAGE	— OPTIMAL HIGH VOLTAGE
CM	CONDENSER MOTOR	— FIELD WIRING	— HIGH VOLTAGE
COMP	COMPRESSOR	— LOW VOLTAGE	
DC	DEFROST CONTROL		
DFT	DEFROST THERMOSTAT		
ECON	ECONOMIZER		
EM	EVAPORATOR MOTOR		
GND	EQUIPMENT GROUND		
HVDR	HIGH VOLTAGE DEFROST RELAY		
LPS	LOW PRESSURE SWITCH		
LVDR	LOW VOLTAGE DEFROST RELAY		
LVJB	LOW VOLTAGE DEFROST RELAY		
PLF	FEMALE PLUG / CONNECTOR		
RVC	REVERSING VALVE COIL		
RCCF	RUN CAPACITOR FOR COMPRESSOR AND FAN		
TR	TRANSFORMER		

WIRE CODE

BK	BLACK
BL	BLUE
BR	BROWN
GR	GREEN
OR	ORANGE
PU	PURPLE
RD	RED
WH	WHITE
YL	YELLOW

- NOTES:**
1. REPLACEMENT WIRE MUST BE SAME SIZE AND TYPE INSULATION AS ORIGINAL (AT LEAST 105°C) USE COPPER CONDUCTOR ONLY.
 2. TO CHANGE EVAPORATOR MOTOR SPEED MOVE WHITE AND YELLOW LEADS FROM EM"2" AND "3" TO "4" AND "5". IF BOTH LEADS ARE ENERGIZED, THE HIGHER SPEED SETTING IS USED.
 3. FOR 208 VOLT TRANSFORMER OPERATION MOVE PURPLE WIRES FROM TERMINAL 3 TO TERMINAL 2 ON TRANSFORMER.
 4. USE COPPER CONDUCTORS ONLY
 5. USE N.E.C. CLASS 2 WIRE
 6. CRANKCASE HEAT NOT SUPPLIED ON ALL UNITS.
 7. WITH ECONOMIZER OPTION USE PURPLE WIRE FOR Y1 AND YELLOW WIRE FOR Y2. WITHOUT ECONOMIZER OPTION USE YELLOW WIRE FOR Y.
 8. ECONOMIZER PLUG LOCATED IN THE RETURN AIR COMPARTMENT, REMOVE MALE PLUG, ATTACH FEMALE PLUG TO ECONOMIZER ACCESSORY.

SEE UNIT RATING PLATE FOR TYPE AND SIZE OF OVER CURRENT PROTECTION

208-240/3/60 0140G00491



High Voltage:
Disconnect all power before servicing or installing this unit. Multiple power sources may be present. Failure to do so may cause property damage, personal injury, or death.



WARNING

Wiring is subject to change. Always refer to the wiring diagram on the unit for the most up-to-date wiring schematic.

ACCESSORIES

Item	Description
GPH13MFR102/103*	Internal filter rack for Downflow Applications
OT18-60A	Outdoor Thermostat Kit with Lockout Stat
OT/EHR18-60	Emergency Heat Relay kit
PGC101/102/103*	Roof Curb for GPC13M-/GPH13M- Electric/Electric Packaged Unit
GPH13MED102/103*	Downflow Economizer for GPC13M-/GPH13M- Packaged Units
PCFR101-103	External Horizontal Filter Rack for Goodman/Amana Packaged Units
PGMDD101/102*	Manual Damper for Downflow Application — Medium Chassis
PGMDMD101/102*	Motorized Damper for Downflow Application — Medium Chassis
PGMDD103*	Manual Damper for Downflow Application — Large Chassis
PGMDMD103*	Motorized Damper for Downflow Application — Large Chassis
PGMDH102*	Manual 25% Fresh Air Damper — Horizontal Applications
PGMDH103*	Manual 25% Fresh Air Damper — Horizontal Applications
PGMDMH102*	Motorized 25% Fresh Air Damper — Horizontal Applications
PGMDMH103*	Motorized 25% Fresh Air Damper — Horizontal Applications
SQRPG101/102*	Square-to-Round Adapter with 16" Round — Downflow Applications
SQRPG103*	Square-to-Round Adapter with 18" Round — Downflow Applications
SQRPGH101/102*	Square-to-Round Adapters for GPC/GPH- Packaged Units 16"&14"
SQRPGH103*	Square-to-Round Adapters for GPC/GPH- Packaged Units 18"&14"

* Offered by McDaniel Metals • Main: (281) 987-8400 • Fax: (281) 987-9494

