



Air Conditioning & Heating

## PRODUCT SPECIFICATIONS



7½ TO 10 Ton

10.3 EER

### COOLING CAPACITY

86,000 - 116,000 BTU/H

### HEATING CAPACITY

193,000 - 225,000 BTU/H



## PGC COMMERCIAL

### PACKAGED GAS/ELECTRIC

The Goodman® PGC Commercial Packaged Gas/Electric Unit features high-efficiency cooling and heating performance and low operating costs. This unit allows for ground-level or rooftop-mount and over/under or downflow applications. Its control box and compressors are easily accessible from side access panels. The PGC Commercial unit is housed in a heavy-gauge, galvanized-steel cabinet with a UV-resistant powder-paint finish.

#### Standard Features

- Dual high-efficiency scroll compressors with internal motor protection (two-stage cooling)
- Heavy-gauge aluminized-steel, tubular heat exchanger cells
- Combination redundant gas valve and regulator
- Two independent condenser coils for two-stage operation
- Power-assisted combustion
- Compressor grommets for vibration isolation
- Integrated DSI Ignition Control
- Centrifugal fan for quiet and efficient operation
- Time delay for compressors' sequence
- Copper tube/aluminum fin coil
- Totally enclosed, permanently lubricated outdoor fan motors
- Fully charged R-22 systems
- High- and low-pressure controls on all systems
- Low ambient switch
- Expansion valve evaporator coil
- Reliable two-stage heating
- Belt-driven, variable-pitch sheave permits multi-speed adjustment

#### Cabinet Features

- Heavy-gauge, galvanized-steel cabinet with attractive Architectural Gray powder-paint finish
- Factory wiring conveniently arranged to install accessories
- Vertical discharge with removable grilles provide easy access to fans and motors
- Galvanized-steel, powder-coated drain pan with ¾" NPT condensate connection
- Base rails with fork slots for convenient handling and added rigidity
- Built-in filter rack holds 2" disposable filters (included)

#### Contents

Nomenclature.....	2
Accessories .....	2
Product Specifications.....	3
Dimensions.....	4
Blower Performance Data .....	6
Cooling Capacity Data.....	7
Heating Capacity Data .....	8
Wiring Diagrams.....	9



**NOMENCLATURE**

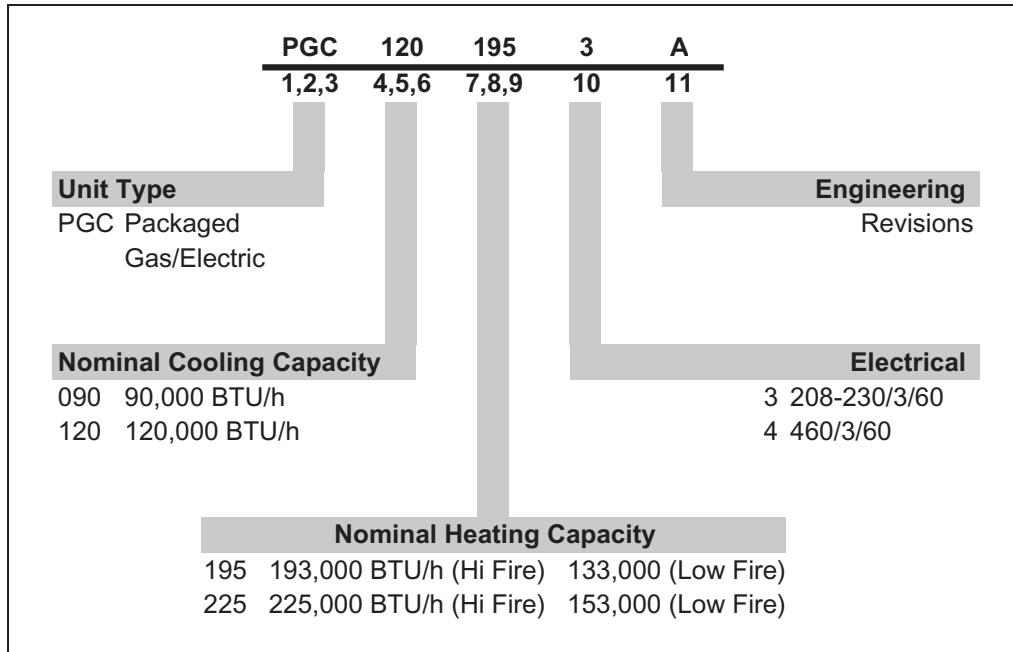

**ACCESSORIES**

Item #	Description
CHT90-120	Two-stage cool/ two-stage heat thermostat
RLK90-120	Rooftop Lift Kit
LA-01	Low Ambient Control
PGC-5	Roof Curb
PGMD-5	Manual Fresh Air Dampers
PGMDM-5	Motorized Fresh Air Dampers
PGED090/102-5A	Enthalpy-controlled economizers
PGED120/180-5A	
PGEH090/102-5	
PGEH120/180-5	
PGHDK090/102-5A	Horizontal Duct Kit
PGHDK120/180-5A	
PLK090/102-5	Panel Louver Kit
PLK120/180-5	
LPW-06	Liquid Propane Kit

**SPECIFICATIONS**

	PGC090195-3	PGC090195-4	PGC120225-3	PGC120225-4
<b>Cooling Capacity</b>				
Total BTU/h	86,000	86,000	116,000	116,000
Sensible BTU/h	63,600	63,600	85,000	85,000
EER <sup>2</sup>	10.3	10.3	10.3	10.3
IPLV <sup>3</sup>	10.7	10.7	10.7	10.7
<b>Heating Capacity</b>				
Max. Input BTU/h	193,000	193,000	225,000	225,000
Min. Input BTU/h	133,000	133,000	153,000	153,000
Output BTU/h	154,400	154,400	180,000	180,000
AFUE	80%	80%	80%	80%
Temperature Rise Range (°F)	35-65	35-65	30-60	30-60
<b>Indoor Blowers (2)</b>				
Type	Belt	Belt	Belt	Belt
Wheel (D x W)	12" x 12"	12" x 12"	12" x 15"	12" x 15"
Indoor Nominal CFM	3,000	3,000	3,800	3,800
Horsepower	1½	1½	3	3
<b>Evaporator Coil (1)</b>				
Face Area (ft²)	11.2	11.2	14	14
Rows Deep/ Fins per Inch	3/ 16	3/ 16	3/ 16	3/ 16
Tube Diameter - Material	¾" - Copper	¾" - Copper	¾" - Copper	¾" - Copper
Filter Size (ft²) / Quantity	25 x 25 x 2 / 3	25 x 25 x 2 / 3	16 x 25 x 2 / 3	16 x 25 x 2 / 3
	—	—	20 x 25 x 2 / 3	20 x 25 x 2 / 3
<b>Condenser Fans (2) / Coil (1)</b>				
Horsepower	½	½	½	½
Fan Diameter	24"	24"	24"	24"
Outdoor Nominal CFM	5,500	5,500	6,400	6,400
Face Area (ft²)	15.6	15.6	23.8	23.8
Rows Deep/ Fins per Inch	2/ 21	2/ 21	2/ 21	2/ 21
Tube Diameter - Material	¾" - Copper	¾" - Copper	¾" - Copper	¾" - Copper
<b>Electrical Data</b>				
Voltage-Phase	208/230-3	460-3	208/230-3	460-3
Compressor RLA/ LRA	12.5/ 88	5.9/ 44	17.4/ 123	6.8/ 49.5
Indoor Blower FLA	4.2	2.1	8.4	4.2
Outdoor Blower FLA	2.6	1.3	2.6	1.3
Min. Circuit Ampacity <sup>4</sup>	38.1	18.2	54.5	22.5
Max. Overcurrent Device <sup>5</sup>	60	30	70	35
<b>Operating Weight (lbs)</b>	1,080	1,080	1,380	1,380
<b>Ship Weight (lbs)</b>	1,100	1,100	1,400	1,400

<sup>1</sup> Sensible capacity is gross, with no deduction for indoor motor heat

<sup>2</sup> BTU/Watt @ 80/ 67° F inside; 95° F outside air

<sup>3</sup> IPLV = Integrated Part Load Valve

<sup>4</sup> Wire size should be determined in accordance with National Electrical Codes. Extensive wire runs will require larger wire sizes.

<sup>5</sup> HACR breakers may be used in place of fuses up to 60 amps

DIMENSIONS

Vertical Discharge  
(Factory Configuration)

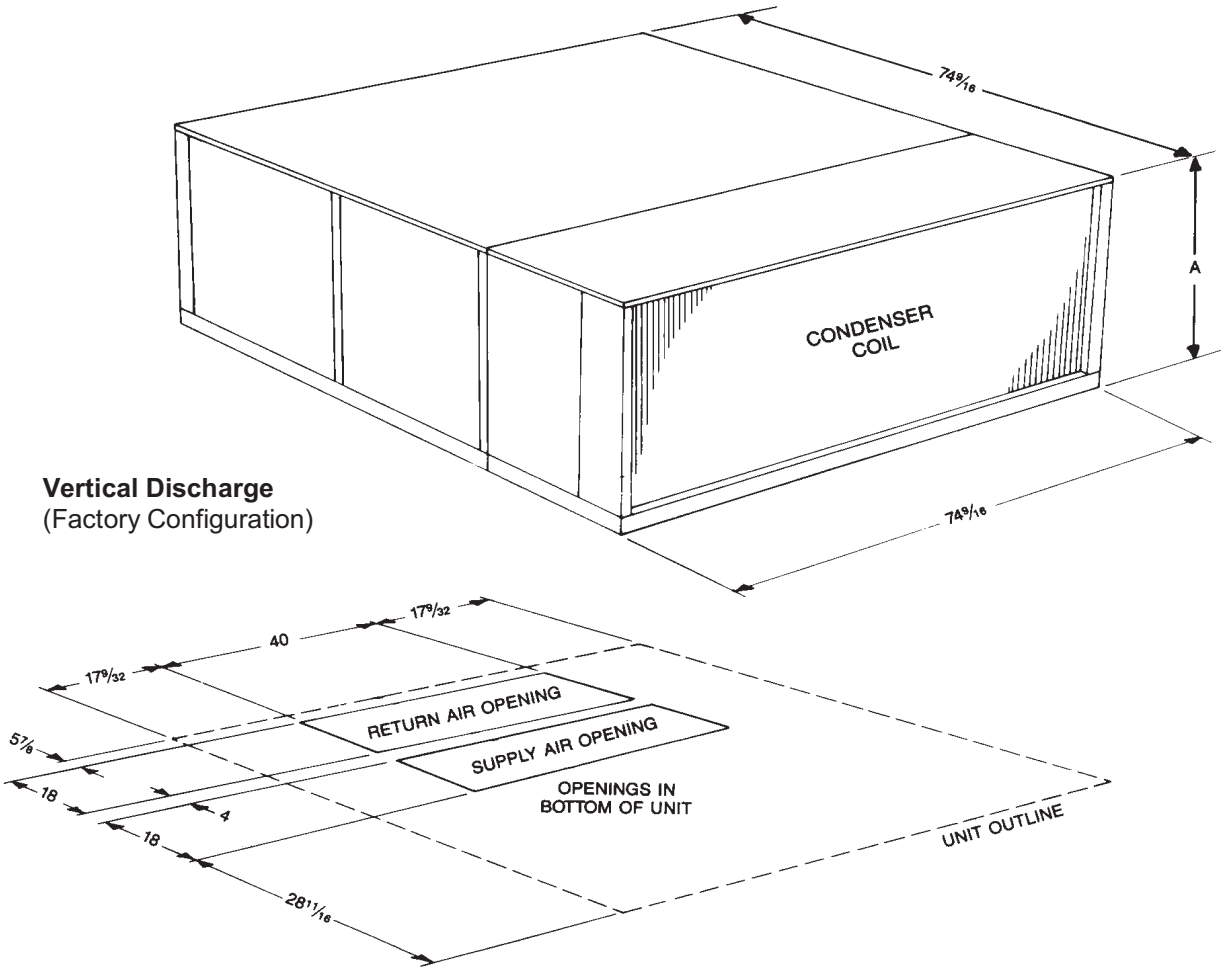

Horizontal Discharge  
(Kit Required)

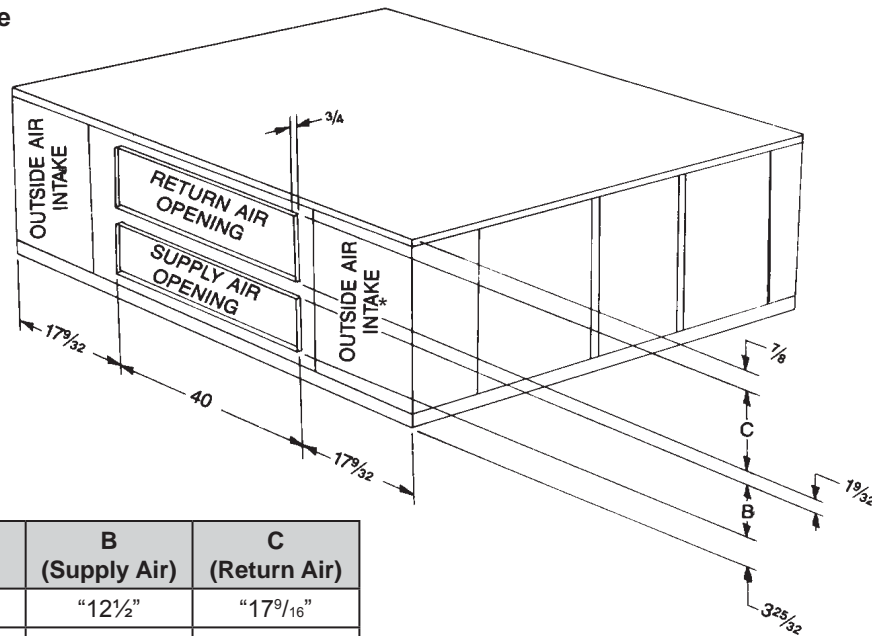

Unit Size	A (Height)	B (Supply Air)	C (Return Air)
PGC090-X	36"	"12 1/2"	"17 9/16"
PGC120-X	52"	"20 1/4"	"25 13/16"

X= Electrical Designation

**DIMENSIONS—ELECTRICAL CONNECTIONS**

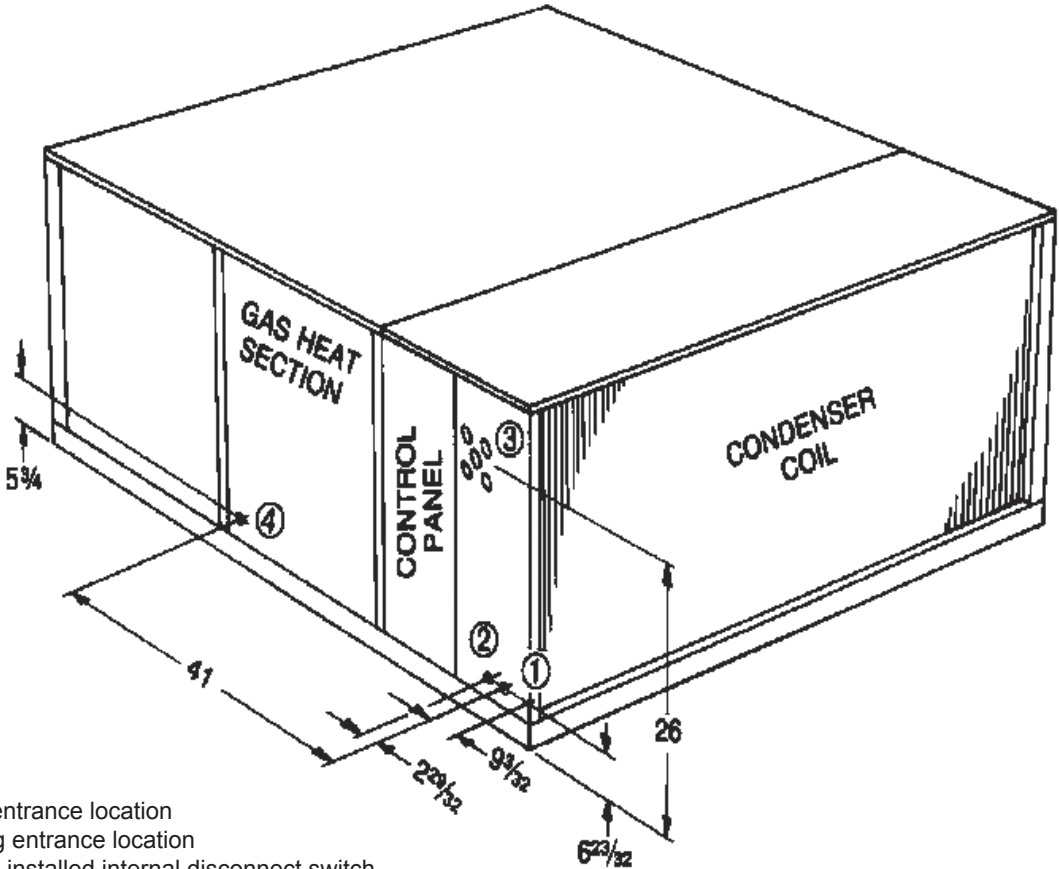

- 1. Main power entrance location
- 2. Control wiring entrance location
- 3. Optional field-installed internal disconnect switch
- 4. Gas piping entrance location

**GAS PIPING CONNECTION SIZE**

Furnace Size	Female NPT
195	3/4"
225	

**COMPONENT PRESSURE DROPS**

Model	CFM	Wet Coil	Gas Furnace Section		Med. Efficiency Filters	Econo. Return Air Damper
			195	225		
PGC090-X	2600	0.06	0.1	-	0.03	0.14
	3000	0.06	0.14	-	0.04	0.14
	3400	0.07	0.17	-	0.05	0.18
PGC120-X	3600	0.05	-	0.13	0.03	0.14
	4000	0.05	-	0.16	0.04	0.14
	4400	0.05	-	0.19	0.04	0.14

**BLOWER PERFORMANCE DATA**

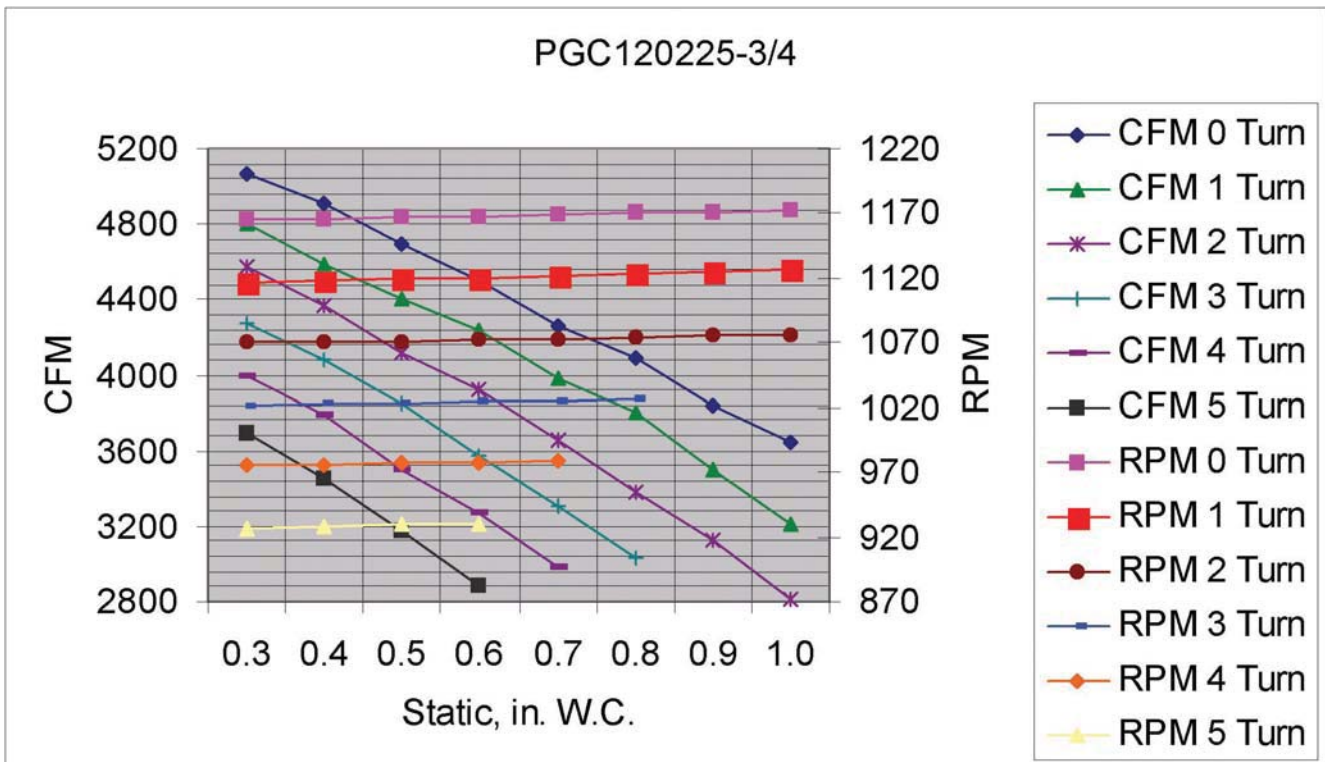
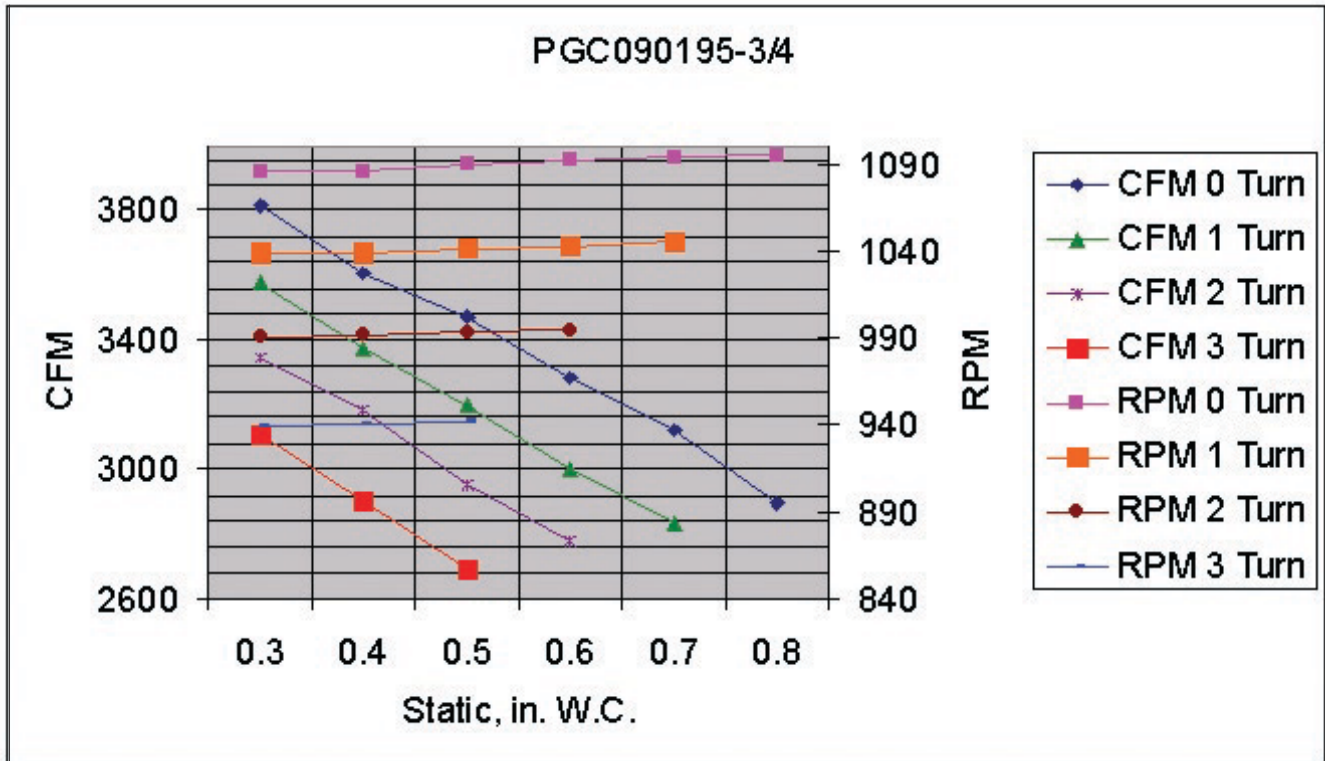

### COOLING CAPACITY DATA — PGC090-X @ 3,000 CFM

AMB. ° F	EVAP. EAT	75° F DB			80° F DB			85° F DB			90° F DB		
		KW	MBHT	MBHS	KW	MBHT	MBHS	KW	MBHT	MBHS	KW	MBHT	MBHS
85	61 WB	7.6	83.8	72.1	7.6	85.7	84.8	7.7	90.6	90.6	7.7	95.5	95.5
	64 WB	7.7	88.7	63.3	7.7	88.7	77.9	7.7	90.6	90.6	7.7	95.5	95.5
	67 WB	7.7	94.5	54.6	7.7	94.5	69.2	7.7	94.5	82.8	7.8	95.5	95.5
	70 WB	7.8	100.3	45.8	7.8	100.3	60.4	7.8	100.3	74.0	7.8	100.3	88.7
	73 WB	7.8	106.2	37.0	7.8	106.2	51.6	7.8	106.2	65.3	7.9	106.2	79.9
90	61 WB	7.8	81.8	71.1	7.9	83.8	83.8	8.0	88.7	88.7	8.0	94.5	94.5
	64 WB	8.0	86.7	62.4	8.0	87.7	77.0	8.0	88.7	88.7	8.0	94.5	94.5
	67 WB	8.1	92.5	53.6	8.1	92.5	68.2	8.1	92.5	82.8	8.1	94.5	94.5
	70 WB	8.1	97.4	44.8	8.1	97.4	59.4	8.1	98.4	74.0	8.2	98.4	87.7
	73 WB	8.2	103.3	36.0	8.2	103.3	50.7	8.2	105.2	64.3	8.4	103.3	78.9
95	61 WB	8.2	80.9	71.1	8.3	82.8	82.8	8.3	87.7	87.7	8.4	93.5	93.5
	64 WB	8.3	85.7	62.4	8.3	85.7	76.0	8.3	87.7	87.7	8.4	93.5	93.5
	67 WB	8.4	90.6	53.6	8.4	90.6	68.2	8.4	90.6	81.8	8.4	93.5	93.5
	70 WB	8.4	96.4	44.8	8.4	96.4	58.5	8.4	96.4	73.1	8.4	96.4	87.7
	73 WB	8.5	101.3	35.1	8.5	101.3	49.7	8.5	101.3	64.3	8.6	101.3	78.9
100	61 WB	8.5	78.9	70.1	8.6	80.9	80.9	8.6	86.7	86.7	8.7	91.6	91.6
	64 WB	8.6	83.8	61.4	8.6	83.8	76.0	8.6	86.7	86.7	8.7	91.6	91.6
	67 WB	8.7	88.7	52.6	8.7	88.7	67.2	8.7	88.7	80.9	8.7	91.6	91.6
	70 WB	8.8	94.5	43.8	8.8	94.5	58.5	8.8	94.5	72.1	8.8	94.5	85.7
	73 WB	8.9	99.4	35.1	9.0	99.4	48.7	9.0	99.4	63.3	9.0	99.4	77.9
105	61 WB	8.9	77.0	69.2	8.9	79.9	79.9	9.0	84.8	84.8	9.1	89.6	89.6
	64 WB	8.9	81.8	60.4	8.9	81.8	75.0	9.0	84.8	84.8	9.1	89.6	89.6
	67 WB	9.1	86.7	51.6	9.1	86.7	66.3	9.1	86.7	79.9	9.1	89.6	89.6
	70 WB	9.1	91.6	42.9	9.1	91.6	57.5	9.2	92.5	71.1	9.2	92.5	85.7
	73 WB	9.4	98.4	34.1	9.4	98.4	48.7	9.4	98.4	62.4	9.4	98.4	77.0

**Notes:**

- Capacities are gross and are based on 230, 460 operation. 208-volt operation must be derated by 0.98. Gross capacities do not include evaporator motor heat
- KW is for entire unit.
- See table for capacity correction factors at other than nominal CFM.

- AMB Ambient Air Temperature
- EAT Entering Air Temperature
- DB Evaporator Dry Bulb EAT
- WB Evaporator Wet Bulb EAT
- KW 1,000 Watts
- MBHT 1,000 BTU/h Total Cooling
- MBHS 1,000 BTU/h Sensible Cooling
- CFM Evaporator Airflow Ft.<sup>3</sup>/min (Table 9a)

SHADED AREA REPRESENTS 100% SENSIBLE COOLING.

### COOLING CAPACITY CORRECTION FACTORS

	CFM						
	-15%	-10%	-5%	STD.	+5%	+10%	+15%
Total MBH	0.971	0.985	0.991	0	1.006	1.012	1.019
Sensible MBH	0.925	0.952	0.974	0	1.024	1.048	1.070
kW	0.985	0.989	0.995	0	1.004	1.006	1.011

## COOLING CAPACITY DATA (CONT.) — PGC120-X @ 4,000 CFM

AMB. °F	EVAP. EAT	75 °F DB			80 °F DB			85 °F DB			90 °F DB		
		KW	MBHT	MBHS	KW	MBHT	MBHS	KW	MBHT	MBHS	KW	MBHT	MBHS
85	61 WB	10.2	115.9	99.7	10.2	118.6	117.2	10.3	125.3	125.3	10.3	132.0	132.0
	64 WB	10.3	122.6	87.6	10.3	122.6	107.8	10.3	125.3	125.3	10.3	132.0	132.0
	67 WB	10.3	130.7	75.4	10.3	130.7	95.6	10.3	130.7	114.5	10.5	132.0	132.0
	70 WB	10.6	138.8	63.3	10.6	138.8	83.5	10.6	138.8	102.4	10.6	138.8	122.6
	73 WB	10.6	146.9	51.2	10.6	146.9	71.4	10.6	146.9	90.3	10.7	146.9	110.5
90	61 WB	10.6	113.2	98.3	10.7	115.9	115.9	10.8	122.6	122.6	10.8	130.7	130.7
	64 WB	10.8	119.9	86.2	10.8	121.3	106.4	10.8	122.6	122.6	10.8	130.7	130.7
	67 WB	10.9	128.0	74.1	10.9	128.0	94.3	10.9	128.0	114.5	10.9	130.7	130.7
	70 WB	10.9	134.7	62.0	10.9	134.7	82.2	10.9	136.1	102.4	11.0	136.1	121.2
	73 WB	11.0	142.8	49.8	11.0	142.8	70.1	11.0	145.5	88.9	11.3	142.8	109.1
95	61 WB	11.0	111.8	98.3	11.1	114.5	114.5	11.1	121.3	121.2	11.3	129.3	129.3
	64 WB	11.1	118.6	86.2	11.1	118.6	105.1	11.1	121.3	121.2	11.3	129.3	129.3
	67 WB	11.3	125.3	74.1	11.3	125.3	94.3	11.3	125.3	113.2	11.4	129.3	129.3
	70 WB	11.3	133.4	62.0	11.4	133.4	80.8	11.4	133.4	101.0	11.4	133.4	121.2
	73 WB	11.5	140.1	48.5	11.5	140.1	68.7	11.5	140.1	88.9	11.6	140.1	109.1
100	61 WB	11.5	109.1	97.0	11.6	111.8	111.8	11.6	119.9	119.9	11.7	126.6	126.6
	64 WB	11.6	115.9	84.9	11.6	115.9	105.1	11.6	119.9	119.9	11.7	126.6	126.6
	67 WB	11.7	122.6	72.7	11.7	122.6	93.0	11.7	122.6	111.8	11.7	126.6	126.6
	70 WB	11.8	130.7	60.6	11.8	130.7	80.8	11.8	130.7	99.7	11.8	130.7	118.5
	73 WB	12.0	137.4	48.5	12.2	137.4	67.4	12.2	137.4	87.6	12.2	137.4	107.8
105	61 WB	12.0	106.4	95.6	12.0	110.5	110.5	12.2	117.2	117.2	12.3	124.0	123.9
	64 WB	12.0	113.2	83.5	12.0	113.2	103.7	12.2	117.2	117.2	12.3	124.0	123.9
	67 WB	12.3	119.9	71.4	12.3	119.9	91.6	12.3	119.9	110.5	12.3	124.0	123.9
	70 WB	12.3	126.6	59.3	12.3	126.6	79.5	12.4	128.0	98.3	12.4	128.0	118.5
	73 WB	12.6	136.1	47.2	12.6	136.1	67.4	12.6	136.1	86.2	12.6	136.1	106.4

See Notes on Page 7.

## HEATING CAPACITY DATA

### GAS HEAT AIR TEMPERATURE RISE

Model	195	225	
Number of Tubes	6	7	
Ventor Motor HP	1/16	1/12	
MBH Input	193	225	
MBH Output	154.4	180.0	
Max. Air Temp. Rise	65	60	
CFM	2,600	55.0	-
	2,800	51.1	-
	3,000	47.7	55.6
	3,200	44.7	52.1
	3,400	42.1	49.1
	3,600	39.7	46.3
	3,800	-	43.9
	4,000	-	41.7
	4,200	-	39.7
	4,400	-	37.9
4,600	-	36.3	

#### Notes

- See Gas Furnace Air Temperature Rise table for furnace availability in various unit sizes.
- Capacities are approved for altitudes to 2,000'. At higher elevations, heating capacity must be reduced 4% (x0.96) for each 1,000' above sea level.
- Air temperature rise is for total heating capacity. Temperature rises at other conditions may be calculated by using the formula  

$$\text{Temperature Rise} = \frac{\text{Output Capacity} - \text{BTU/h}}{1.08 \times \text{ft.}^3/\text{min. Airflow}}$$
- For altitudes over 2,000', air temperature rise must be calculated using the formula:  

$$\text{Temperature Rise} = \frac{\text{Output Capacity} - \text{BTU/h}}{14.4 \times \text{ft.}^3/\text{min. airflow} \times \text{specific weight of air}}$$
- Two-stage control is standard.
- Output capacity based on nominal 1,000 BTU/Ft.<sup>3</sup> natural gas or 2,500 Btu/Ft.<sup>3</sup> propane

### GAS FURNACE AIR TEMPERATURE RISE

Unit Size	Model Number	
	195	225
7½	X	N/A
10	N/A	X

### EVAPORATOR MOTOR HEAT

Horsepower	BTU/h
1.5	4,650
3	9,300

X - Furnace Available  
 N/A - Furnace Not Available

# WIRING DIAGRAM — PGC 24-36

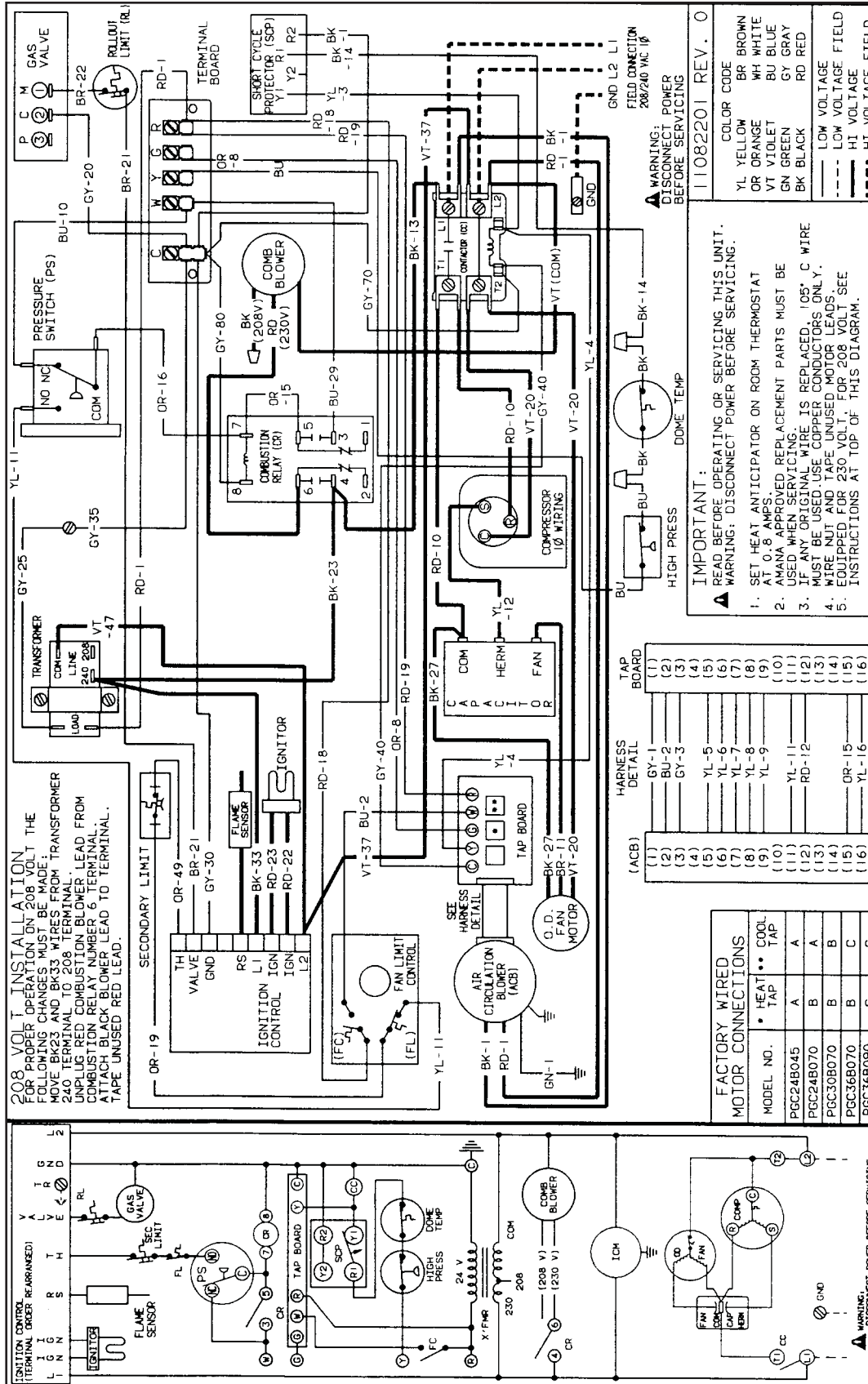

Wiring is subject to change. Always refer to the wiring diagram on the unit for the most up-to-date wiring.

**WARNING**

**High Voltage:**  
 Disconnect all power before servicing or installing this unit. Multiple power sources may be present. Failure to do so may cause property damage, personal injury, or death.

# WIRING DIAGRAM — PGC 42

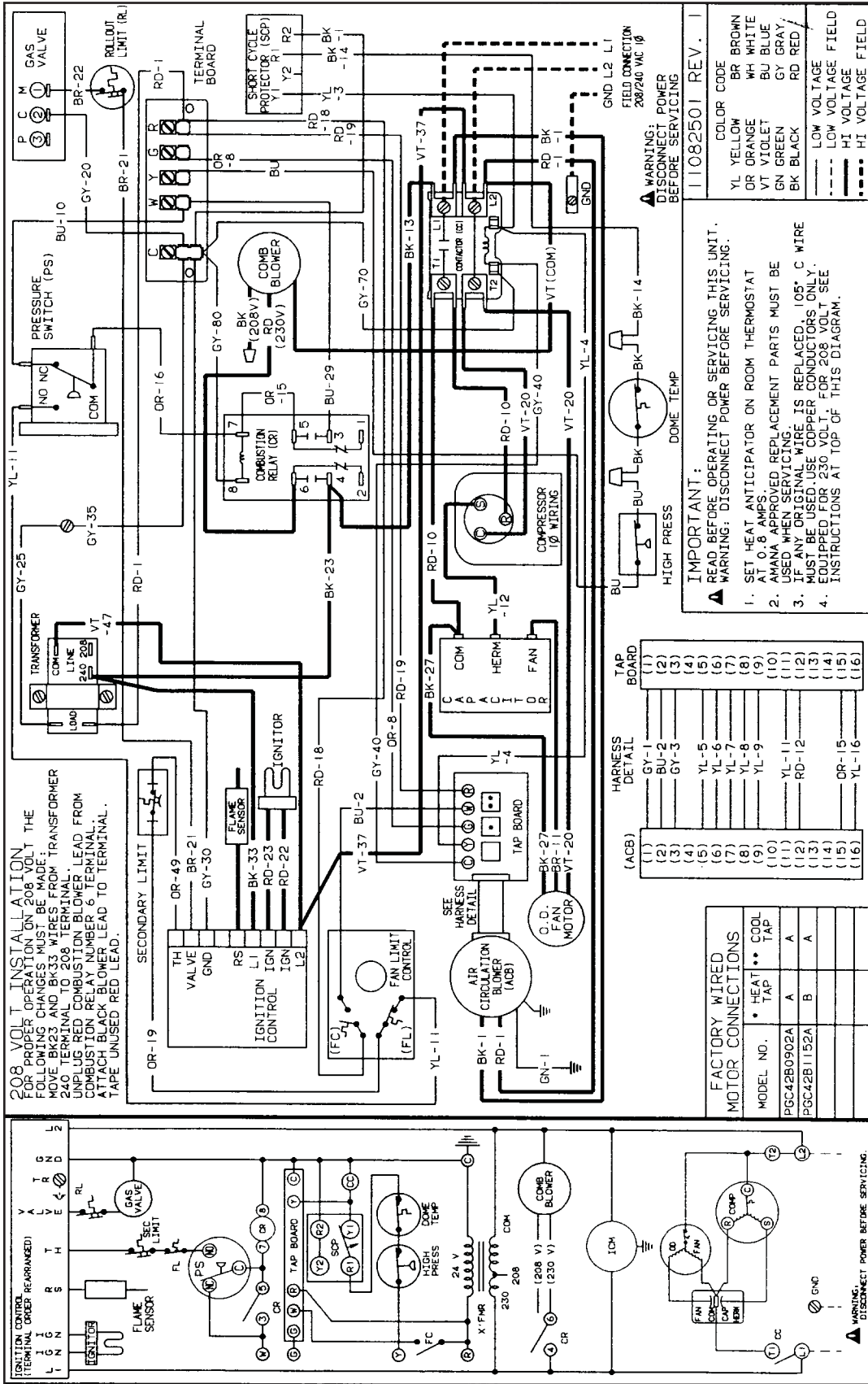

Wiring is subject to change. Always refer to the wiring diagram on the unit for the most up-to-date wiring.

**WARNING**

**High Voltage:**  
 Disconnect all power before servicing or installing this unit. Multiple power sources may be present. Failure to do so may cause property damage, personal injury, or death.

# WIRING DIAGRAM — PGC 48

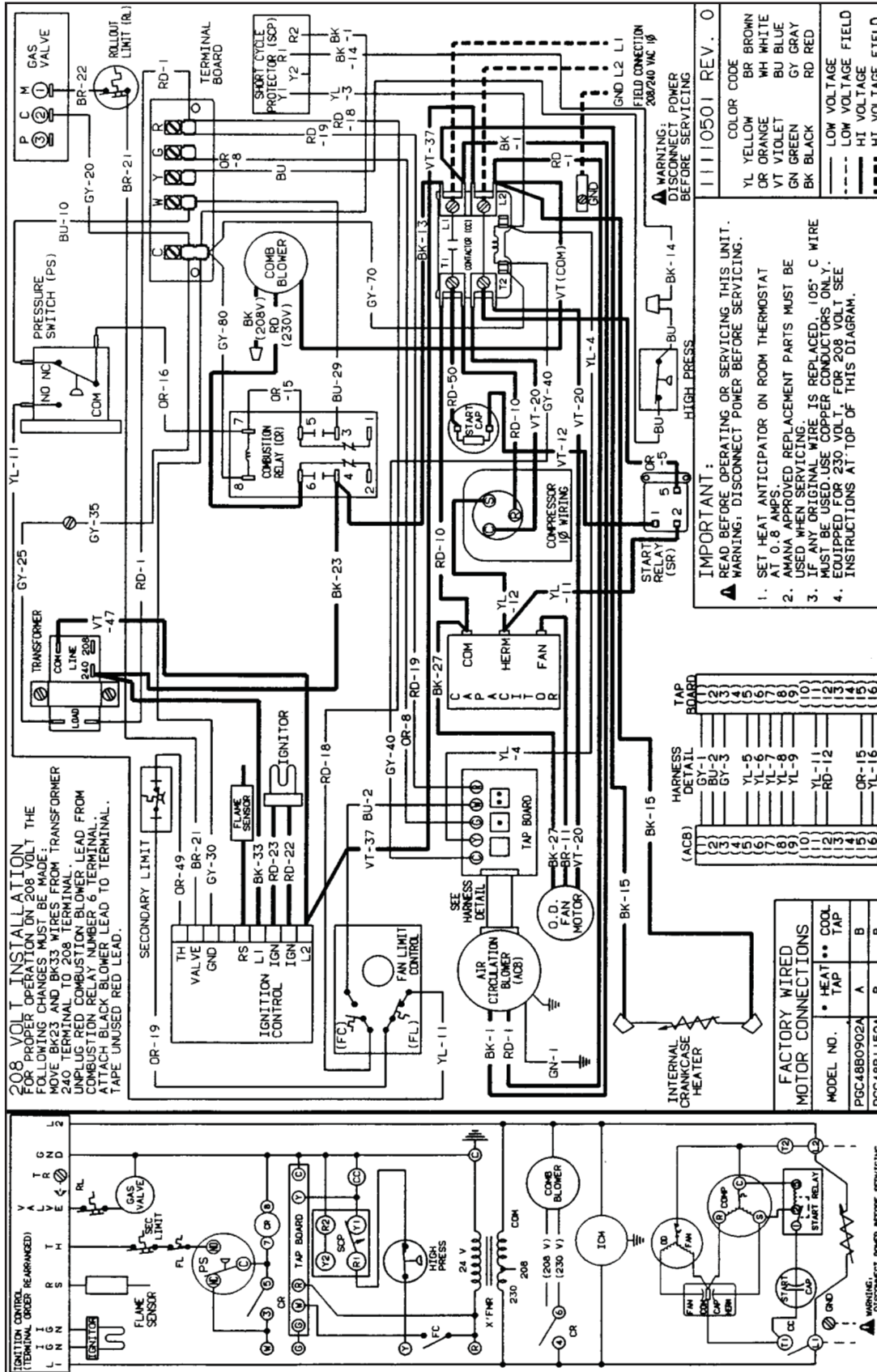

Wiring is subject to change. Always refer to the wiring diagram on the unit for the most up-to-date wiring.



**WARNING**

**High Voltage:**  
 Disconnect all power before servicing or installing this unit. Multiple power sources may be present. Failure to do so may cause property damage, personal injury, or death.



# WIRING DIAGRAM — PGC 60

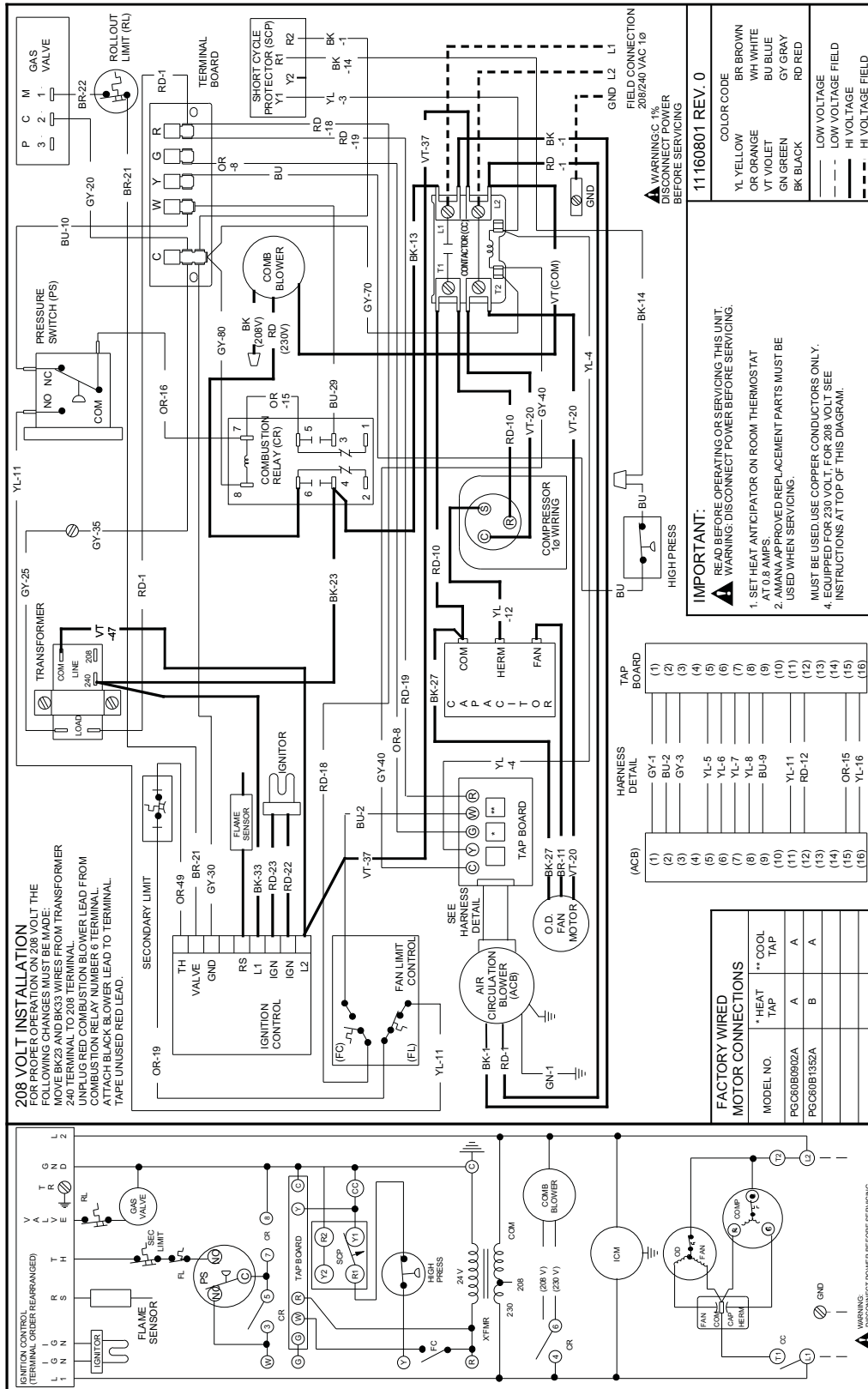

Wiring is subject to change. Always refer to the wiring diagram on the unit for the most up-to-date wiring.



**High Voltage:**  
Disconnect all power before servicing or installing this unit. Multiple power sources may be present. Failure to do so may cause property damage, personal injury, or death.

