



Air Conditioning & Heating

PRODUCT SPECIFICATIONS



13 SEER

3- TO 5-TON

COOLING CAPACITY 35,000 - 56,000 BTU/H

GPC13M COMMERCIAL

PACKAGED AIR CONDITIONER

The Goodman® GPC13M Commercial Packaged Air Conditioner features energy-efficient cooling and heating performance in one self-contained unit. This unit is housed in a heavy-gauge, galvanized-steel cabinet protected by a high-quality, UV-resistant powder-paint finish and allows for a ground-level or rooftop mount.

Standard Features

- Energy-efficient compressor with internal relief valve
- EEM blower motor; PSC blower motor on 3-ton units
- Convertible airflow — horizontal or downflow
- Copper tube/aluminum fin coil
- Totally enclosed, permanently lubricated condenser fan motor
- Fully charged R-22 system
- Electric heat kit available as a field-installed accessory

Cabinet Features

- Heavy-gauge galvanized-steel cabinet with attractive Architectural Gray powder-paint finish
- Fully insulated blower compartment with convenient access panels
- Louvered condenser coil protection
- One footprint; two heights

Contents

Nomenclature.....	2
Product Specifications.....	3
Evaporator Blower Specifications.....	4
Expanded Cooling Data.....	6
Dimensions.....	12
Wiring Diagrams.....	13
Accessories	15



NOMENCLATURE

	<u>G</u> 1	<u>P</u> 2	<u>H</u> 3	<u>13</u> 4,5	<u>36</u> 6,7	<u>M</u> 8	<u>2</u> 9	<u>3</u> 10	<u>A</u> 11	<u>*</u> 12	
Brand G Goodman or Distinctions™										Engineering Minor Revision	
Packaged Unit P										Engineering Major Revision	
Type C Air Conditioner H Heat Pump										Voltage Designator 1 208-230/1/60 3 208-230/3/60 4 460/3/60	
Efficiency 13 13 SEER 14 14 SEER 15 15 SEER 16 16 SEER										Refrigerant 2 R-22 4 R-410A	
Nominal Capacity 36 3 Tons 48 4 Tons 60 5 Tons										Configuration H Horizontal M Multi-position	

SPECIFICATIONS

	GPC1336M23A*	GPC1348M23A*	GPC1360M23A*
Cooling Capacity			
Total BTU/h	35,000	47,000	56,500
Sensible BTU/h	26,200	36,000	42,000
SEER / EER	13/11.1	13/11.1	13/10.8
Decibels	77	78	78
Evaporator Motor			
Type	DD	DD	DD
Nominal Cooling CFM	1,225	1,750	1,900
Wheel (DxW)	10 x 9	10 x 9	10 x 9
No. of Speeds	3	5	5
Horsepower - RPM	1/3	3/4	1.0
Evaporator Coil			
Face Area (ft ²)	4.5	6.2	6.2
Rows Deep/ Fin per Inch	4	4	4
Drain Size (NPT)	3/4"	3/4"	3/4"
Refrigerant Charge (oz.)	110	158	209
Condenser Fan / Coil			
Horsepower - RPM	1/4 - 1,075	1/3 - 1,075	1/3 - 1,075
Fan Diameter / # Fan Blades	22 / 3	22 / 4	22 / 4
Face Area (ft ²)	12.5	15.3	21.2
Rows Deep/ Fins per Inch	2	2	2
Electrical Data			
Voltage-Phase	208/230-3	208/230-3	208/230-3
Compressor RLA/LRA	9 / 65.5	12.2 / 88	15.4 / 128
Indoor Blower FLA / LRA	1.9 / 3.6	6 / -	7.6 / -
Outdoor Fan FLA / LRA	1.4 / 3	2.4 / 5.2	2.4 / 5.2
Total Unit Amps	10.2	16	19.3
Min. Circuit Ampacity ¹	14.5	23.6	29.3
Max. Overcurrent Protection ²	20	30	40
Ship Weight (lbs)	416	459	511

¹ Wire size should be determined in accordance with National Electrical Codes. Extensive wire runs will require larger wire sizes.

² May use fuses or HACR-type circuit breakers of the same size as noted.

EVAPORATOR BLOWER SPECIFICATIONS

Model	Speed	Volts		E.S.P (In. of H ₂ O)							
				0.1	0.2	0.3	0.4	0.5	0.6	0.7	0.8
GPC13 36M23A	Low	230	CFM	1,055	1,015	975	895	840	770	-	-
			Watts	315	310	300	285	270	255	-	-
	M / L	230	CFM	1,285	1,240	1,190	1,120	1,040	950	850	-
			Watts	385	375	365	350	335	315	295	-
	M / H	230	CFM	1,470	1,425	1,345	1,285	1,195	1,085	980	865
			Watts	455	440	425	410	385	370	350	325
	High	230	CFM	1,565	1,510	1,415	1,340	1,260	1,135	1,035	885
			Watts	495	480	460	445	425	405	385	355
GPC13 48M23A	T1 (G)	230	CFM	1,440	1,395	1,360	1,310	1,265	1,235	1,190	1,130
			Watts	275	285	295	315	325	335	345	355
	T2 / T3 (W2)	230	CFM	1,795	1,765	1,715	1,695	1,650	1,600	1,500	1,375
			Watts	475	490	505	520	530	535	510	475
	T4 / T5 (Y)	230	CFM	1,860	1,820	1,785	1,745	1,700	1,625	1,515	1,395
			Watts	515	530	545	565	570	550	535	485
GPC13 60M23A	T1 (G)	230	CFM	1,755	1,720	1,685	1,645	1,615	1,570	1,530	1,465
			Watts	420	435	455	460	475	490	500	500
	T2 / T3 W2	230	CFM	1,850	1,820	1,775	1,735	1,705	1,675	1,610	1,495
			Watts	480	500	515	525	535	555	545	520
	T4 / T5 Y	230	CFM	2,180	2,125	2,050	1,975	1,875	1,800	1,655	1,530
			Watts	770	755	725	700	675	640	575	540

Notes:

- Data shown is dry coil. Wet coil pressure drop is approximately 0.1" H₂O, for two-row indoor coil; 0.2" H₂O, for three-row indoor coil; and 0.3" H₂O, for four-row indoor coil.
- Data shown does not include filter pressure drop, approximately 0.08" H₂O.
- ALL MODELS SHOULD RUN NO LESS THAN 350 CFM/TON. USE HIGHER SPEED TAP OR NEXT SIZE LARGER BLOWER ASM. See Repair Parts list.
- Reduce airflow by 2% for 208-volt operation.

EVAPORATOR BLOWER SPECIFICATIONS (CONT.)

BTU OUTPUT vs TEMPERATURE RISE CHART

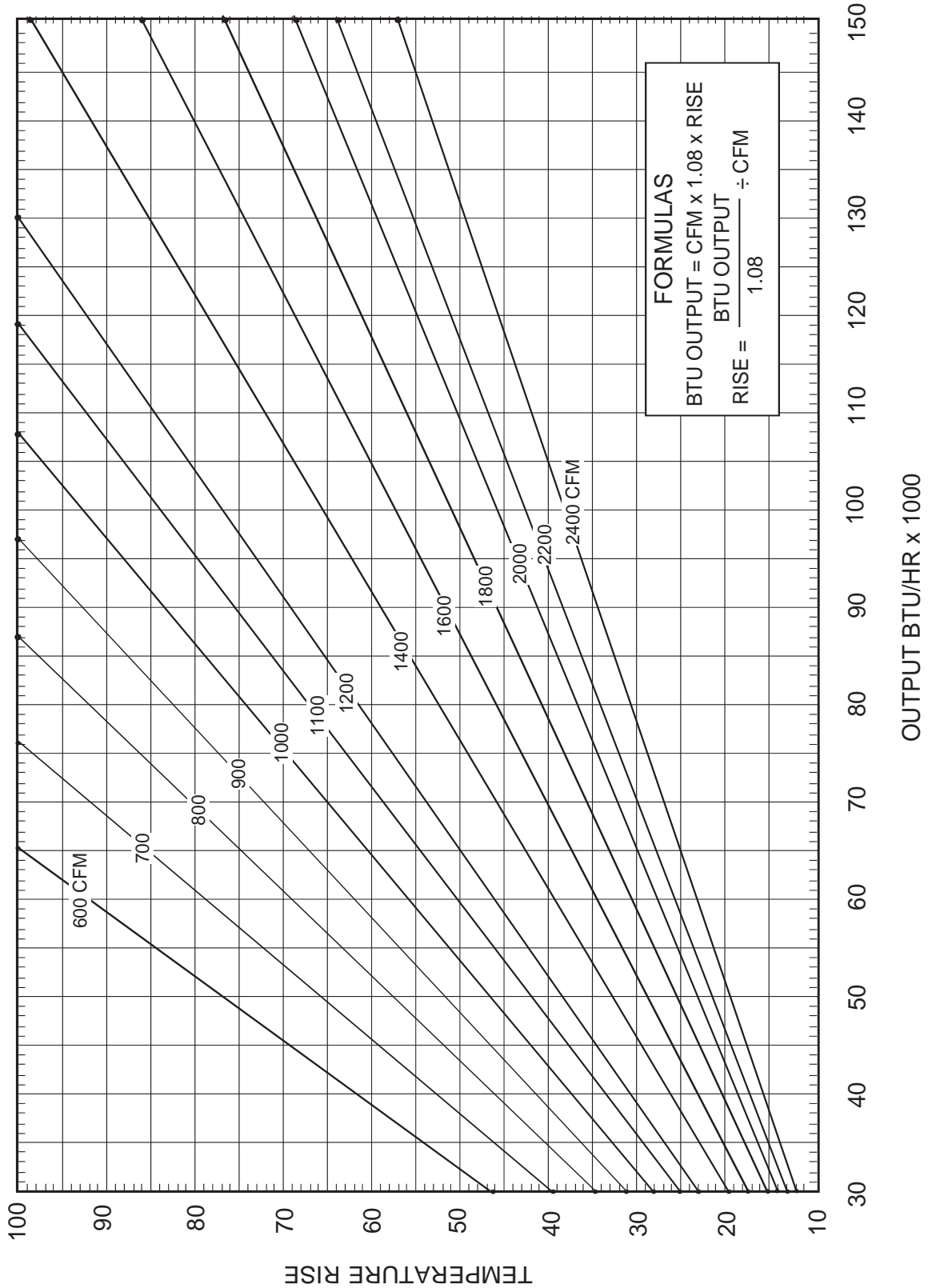

EXPANDED COOLING DATA — GPC1336M23A

IDB	Airflow	Outdoor Ambient Temperature																							
		65°F				75°F				85°F				95°F				105°F				115°F			
		59	63	67	71	59	63	67	71	59	63	67	71	59	63	67	71	59	63	67	71	59	63	67	71
1378	MBh	34.3	35.5	38.9	-	33.5	34.7	38.0	-	32.7	33.9	37.1	-	31.9	33.1	36.2	-	30.3	31.4	34.4	-	28.1	29.1	31.9	-
	S/T	0.75	0.63	0.44	-	0.78	0.65	0.45	-	0.80	0.67	0.46	-	0.83	0.69	0.48	-	0.86	0.72	0.50	-	0.86	0.72	0.50	-
	ΔT	17	15	11	-	17	15	11	-	17	15	11	-	18	15	12	-	17	15	11	-	16	14	11	-
	kW	2.51	2.56	2.63	-	2.69	2.74	2.82	-	2.84	2.90	2.98	-	2.97	3.03	3.13	-	3.09	3.15	3.25	-	3.19	3.25	3.35	-
	Amps	8.2	8.4	8.6	-	8.7	8.8	9.1	-	9.2	9.4	9.6	-	9.7	9.9	10.1	-	10.2	10.4	10.6	-	10.6	10.8	11.1	-
	Hi PR	153	165	174	-	172	185	196	-	196	211	222	-	223	240	253	-	251	270	285	-	277	298	315	-
	Lo PR	65	70	76	-	69	73	80	-	72	76	83	-	75	80	88	-	79	84	92	-	82	87	95	-
	MBh	33.3	34.5	37.8	-	32.5	33.7	36.9	-	31.7	32.9	36.1	-	31.0	32.1	35.2	-	29.4	30.5	33.4	-	27.3	28.3	31.0	-
	S/T	0.72	0.60	0.42	-	0.74	0.62	0.43	-	0.76	0.64	0.44	-	0.79	0.66	0.46	-	0.82	0.68	0.47	-	0.82	0.69	0.48	-
	ΔT	18	16	12	-	18	16	12	-	18	16	12	-	18	16	12	-	18	16	12	-	17	15	11	-
70	kW	2.50	2.54	2.62	-	2.67	2.72	2.80	-	2.82	2.87	2.96	-	2.95	3.01	3.10	-	3.07	3.13	3.22	-	3.16	3.23	3.33	-
	Amps	8.2	8.3	8.5	-	8.6	8.8	9.0	-	9.2	9.3	9.6	-	9.6	9.8	10.1	-	10.1	10.3	10.5	-	10.6	10.8	11.0	-
	Hi PR	152	163	173	-	170	183	194	-	194	209	220	-	221	238	251	-	248	267	282	-	274	295	312	-
	Lo PR	65	69	75	-	68	73	79	-	71	76	83	-	75	79	87	-	78	83	91	-	81	86	94	-
	MBh	30.7	31.9	34.9	-	30.0	31.1	34.1	-	29.3	30.4	33.3	-	28.6	29.6	32.5	-	27.2	28.2	30.8	-	25.2	26.1	28.6	-
	S/T	0.69	0.58	0.40	-	0.72	0.60	0.42	-	0.74	0.61	0.43	-	0.76	0.63	0.44	-	0.79	0.66	0.46	-	0.80	0.66	0.46	-
	ΔT	18	16	12	-	18	16	12	-	19	16	12	-	19	16	12	-	18	16	12	-	17	15	11	-
	kW	2.44	2.49	2.56	-	2.61	2.66	2.74	-	2.76	2.81	2.89	-	2.89	2.94	3.03	-	3.00	3.06	3.15	-	3.09	3.15	3.25	-
	Amps	8.0	8.2	8.3	-	8.5	8.6	8.8	-	9.0	9.1	9.4	-	9.4	9.6	9.8	-	9.9	10.1	10.3	-	10.3	10.5	10.8	-
	Hi PR	147	159	167	-	165	178	188	-	188	202	214	-	214	230	243	-	241	259	274	-	266	286	302	-
Lo PR	63	67	73	-	66	71	77	-	69	73	80	-	72	77	84	-	76	81	88	-	79	84	91	-	

1378	MBh	34.9	35.9	38.9	41.7	34.1	35.1	38.0	40.7	33.3	34.2	37.1	39.8	32.4	33.4	36.2	38.8	30.8	31.7	34.4	36.9	28.6	29.4	31.8	34.2
	S/T	0.86	0.77	0.58	0.37	0.89	0.79	0.60	0.39	0.91	0.81	0.62	0.40	0.94	0.84	0.64	0.41	0.97	0.87	0.66	0.42	0.98	0.88	0.67	0.43
	ΔT	20	18	15	10	20	19	15	11	20	19	15	11	20	19	15	11	20	18	15	10	19	17	14	10
	kW	2.53	2.58	2.65	2.73	2.71	2.76	2.84	2.92	2.86	2.92	3.00	3.10	3.00	3.06	3.15	3.25	3.11	3.18	3.27	3.37	3.21	3.28	3.38	3.49
	Amps	8.3	8.4	8.6	8.8	8.8	8.9	9.1	9.4	9.3	9.5	9.7	10.0	9.8	9.9	10.2	10.5	10.2	10.4	10.7	11.0	10.7	10.9	11.2	11.5
	Hi PR	155	167	176	184	174	187	198	206	198	213	225	234	225	242	256	267	253	273	288	300	280	301	318	332
	Lo PR	66	70	77	82	70	74	81	86	73	77	84	90	76	81	88	94	80	85	93	99	83	88	96	102
	MBh	33.9	34.9	37.7	40.5	33.1	34.1	36.9	39.6	32.3	33.2	36.0	38.6	31.5	32.4	35.1	37.7	29.9	30.8	33.3	35.8	27.7	28.5	30.9	33.2
	S/T	0.82	0.73	0.55	0.36	0.85	0.76	0.57	0.37	0.87	0.78	0.59	0.38	0.90	0.80	0.61	0.39	0.93	0.83	0.63	0.40	0.94	0.84	0.63	0.41
	ΔT	21	19	16	11	21	19	16	11	21	19	16	11	21	20	16	11	21	19	16	11	20	18	15	10
75	kW	2.51	2.56	2.63	2.71	2.69	2.74	2.82	2.90	2.84	2.90	2.98	3.07	2.97	3.03	3.13	3.22	3.09	3.15	3.25	3.35	3.19	3.25	3.35	3.46
	Amps	8.2	8.4	8.6	8.8	8.7	8.8	9.1	9.3	9.2	9.4	9.6	9.9	9.7	9.9	10.1	10.4	10.2	10.4	10.6	10.9	10.6	10.8	11.1	11.4
	Hi PR	153	165	174	182	172	185	196	204	196	211	223	232	223	240	253	264	251	270	285	297	277	298	315	329
	Lo PR	65	70	76	81	69	74	80	85	72	76	83	89	75	80	88	93	79	84	92	98	82	87	95	101
	MBh	31.3	32.2	34.8	37.4	30.5	31.4	34.0	36.5	29.8	30.7	33.2	35.6	29.1	29.9	32.4	34.8	27.6	28.4	30.8	33.0	25.6	26.3	28.5	30.6
	S/T	0.79	0.70	0.53	0.34	0.82	0.73	0.55	0.36	0.84	0.75	0.57	0.36	0.86	0.77	0.58	0.38	0.90	0.80	0.61	0.39	0.90	0.81	0.61	0.39
	ΔT	21	19	16	11	21	20	16	11	21	20	16	11	22	20	16	11	21	20	16	11	20	18	15	10
	kW	2.46	2.51	2.58	2.65	2.63	2.68	2.76	2.84	2.78	2.83	2.91	3.00	2.91	2.97	3.05	3.15	3.02	3.08	3.17	3.27	3.11	3.18	3.27	3.38
	Amps	8.1	8.2	8.4	8.6	8.5	8.7	8.9	9.1	9.0	9.2	9.4	9.7	9.5	9.7	9.9	10.2	10.0	10.1	10.4	10.7	10.4	10.6	10.9	11.2
	Hi PR	149	160	169	176	167	180	190	198	190	204	216	225	216	233	246	256	243	262	277	288	269	289	306	319
Lo PR	63	67	74	78	67	71	78	83	70	74	81	86	73	78	85	91	77	82	89	95	79	84	92	98	

Shaded area reflects ACCA (TVA) conditions IDB: Entering Indoor Dry Bulb Temperature kW = Total system power Amps = outdoor unit amps (comp.+fan)
 High and low pressures are measured at the liquid and suction service valves.

EXPANDED COOLING DATA — GPC1336M23A (CONT.)

IDB		Outdoor Ambient Temperature																											
		65°F				75°F				85°F				95°F				105°F				115°F							
		59	63	67	71	59	63	67	71	59	63	67	71	59	63	67	71	59	63	67	71	59	63	67	71				
		Entering Indoor Wet Bulb Temperature																											
80	Airflow	59	63	67	71	59	63	67	71	59	63	67	71	59	63	67	71	59	63	67	71	59	63	67	71	59	63	67	71
	MBh	35.5	36.3	38.8	41.4	34.7	35.4	37.9	40.5	33.8	34.6	37.0	39.5	33.0	33.7	36.1	38.5	31.4	32.1	34.2	36.6	29.1	29.7	31.7	33.9				
	S/T	0.94	0.88	0.72	0.54	1.00	0.91	0.74	0.56	1.00	0.94	0.76	0.57	1.00	0.97	0.79	0.59	1.00	1.00	0.82	0.61	1.00	1.00	0.82	0.62				
	ΔT	22	21	19	15	23	22	19	15	22	22	19	15	22	22	19	15	21	21	19	15	19	20	17	14				
	kW	2.55	2.60	2.67	2.75	2.73	2.78	2.86	2.95	2.88	2.94	3.03	3.12	3.02	3.08	3.17	3.27	3.14	3.20	3.30	3.40	3.24	3.30	3.41	3.51				
	Amps	8.3	8.5	8.7	8.9	8.8	9.0	9.2	9.4	9.4	9.5	9.8	10.0	9.8	10.0	10.3	10.6	10.3	10.5	10.8	11.1	10.8	11.0	11.3	11.6				
	Hi PR	157	168	178	186	176	189	200	208	200	215	227	237	228	245	259	270	256	275	291	303	283	304	321	335				
	Lo PR	67	71	77	83	70	75	82	87	73	78	85	91	77	82	89	95	81	86	94	100	83	89	97	103				
	MBh	34.5	35.2	37.6	40.2	33.7	34.4	36.8	39.3	32.9	33.6	35.9	38.4	32.1	32.8	35.0	37.4	30.5	31.1	33.3	35.5	28.2	28.8	30.8	32.9				
	S/T	0.90	0.84	0.68	0.51	0.93	0.87	0.71	0.53	0.95	0.89	0.73	0.54	0.98	0.92	0.75	0.56	1.00	0.96	0.78	0.58	1.00	0.96	0.78	0.59				
ΔT	23	22	19	15	23	22	20	16	23	22	20	16	24	23	20	16	23	22	19	16	21	21	18	14					
kW	2.53	2.58	2.65	2.73	2.71	2.76	2.84	2.92	2.86	2.92	3.00	3.10	3.00	3.06	3.15	3.25	3.11	3.18	3.27	3.38	3.21	3.28	3.38	3.49					
Amps	8.3	8.4	8.6	8.8	8.8	8.9	9.1	9.4	9.3	9.5	9.7	10.0	9.8	9.9	10.2	10.5	10.2	10.4	10.7	11.0	10.7	10.9	11.2	11.5					
Hi PR	155	167	176	184	174	187	198	206	198	213	225	234	225	242	256	267	253	273	288	300	280	301	318	332					
Lo PR	66	70	77	82	70	74	81	86	73	77	84	90	76	81	89	94	80	85	93	99	83	88	96	102					
MBh	31.8	32.5	34.7	37.1	31.1	31.7	33.9	36.3	30.3	31.0	33.1	35.4	29.6	30.2	32.3	34.5	28.1	28.7	30.7	32.8	26.0	26.6	28.4	30.4					
S/T	0.86	0.81	0.66	0.49	0.90	0.84	0.68	0.51	0.92	0.86	0.70	0.52	0.95	0.89	0.72	0.54	0.98	0.92	0.75	0.56	0.99	0.93	0.76	0.57					
ΔT	24	23	20	16	24	23	20	16	24	23	20	16	24	23	20	16	24	23	20	16	22	21	18	15					
kW	2.48	2.53	2.60	2.67	2.65	2.70	2.78	2.86	2.80	2.85	2.94	3.02	2.93	2.99	3.08	3.17	3.04	3.10	3.20	3.30	3.14	3.20	3.30	3.40					
Amps	8.1	8.3	8.4	8.7	8.6	8.7	8.9	9.2	9.1	9.3	9.5	9.8	9.6	9.7	10.0	10.3	10.0	10.2	10.5	10.8	10.5	10.7	11.0	11.3					
Hi PR	150	162	171	178	169	182	192	200	192	206	218	227	219	235	248	259	246	265	279	291	272	292	309	322					
Lo PR	64	68	74	79	68	72	79	84	70	75	82	87	74	79	86	91	77	82	90	96	80	85	93	99					

85	MBh	36.1	36.8	38.6	41.1	35.3	36.0	37.7	40.2	34.4	35.1	36.8	39.2	33.6	34.2	35.9	38.3	31.9	32.5	34.1	36.4	29.6	30.1	31.6	33.7
	S/T	0.98	0.95	0.86	0.70	1.00	0.98	0.89	0.72	1.00	1.00	0.91	0.74	1.00	1.00	0.94	0.76	1.00	1.00	0.98	0.79	1.00	1.00	0.98	0.80
	ΔT	24	23	22	19	24	24	22	19	23	23	22	19	22	23	23	19	21	22	22	19	20	20	21	18
	kW	2.57	2.62	2.69	2.77	2.75	2.80	2.88	2.97	2.90	2.96	3.05	3.14	3.04	3.10	3.20	3.30	3.16	3.23	3.32	3.43	3.26	3.33	3.43	3.54
	Amps	8.4	8.5	8.7	9.0	8.9	9.0	9.2	9.5	9.4	9.6	9.8	10.1	9.9	10.1	10.3	10.6	10.4	10.6	10.9	11.2	10.9	11.1	11.4	11.7
	Hi PR	158	170	180	187	177	191	202	210	202	217	229	239	230	247	261	272	259	278	294	306	286	307	325	339
	Lo PR	67	72	78	83	71	76	83	88	74	79	86	92	78	83	90	96	81	87	95	101	84	90	98	104
	MBh	35.1	35.7	37.4	39.9	34.3	34.9	36.6	39.0	33.4	34.1	35.7	38.1	32.6	33.3	34.8	37.2	31.0	31.6	33.1	35.3	28.7	29.3	30.6	32.7
	S/T	0.94	0.91	0.82	0.66	0.97	0.94	0.85	0.69	1.00	0.96	0.87	0.71	1.00	0.99	0.90	0.73	1.00	1.00	0.93	0.76	1.00	1.00	0.94	0.76
	ΔT	25	24	23	20	25	25	23	20	25	25	23	20	24	25	23	20	23	24	23	20	22	22	22	19
kW	2.55	2.60	2.67	2.75	2.73	2.78	2.86	2.95	2.88	2.94	3.03	3.12	3.02	3.08	3.17	3.27	3.14	3.20	3.30	3.40	3.24	3.30	3.41	3.51	
Amps	8.3	8.5	8.7	8.9	8.8	9.0	9.2	9.4	9.4	9.5	9.8	10.0	9.8	10.0	10.3	10.6	10.3	10.5	10.8	11.1	10.8	11.0	11.3	11.6	
Hi PR	157	168	178	186	176	189	200	208	200	215	227	237	228	245	259	270	256	275	291	303	283	304	321	335	
Lo PR	67	71	77	83	70	75	82	87	73	78	85	91	77	82	89	95	81	86	94	100	83	89	97	103	
MBh	32.4	33.0	34.6	36.9	31.6	32.2	33.8	36.0	30.9	31.5	32.9	35.1	30.1	30.7	32.1	34.3	28.6	29.2	30.5	32.6	26.5	27.0	28.3	30.2	
S/T	0.91	0.87	0.79	0.64	0.94	0.91	0.82	0.66	0.96	0.93	0.84	0.68	0.99	0.96	0.86	0.70	1.00	0.99	0.90	0.73	1.00	1.00	0.91	0.73	
ΔT	25	25	23	20	25	25	24	20	25	25	24	20	26	25	24	21	25	25	24	20	23	23	22	19	
kW	2.50	2.54	2.61	2.69	2.67	2.72	2.80	2.88	2.82	2.87	2.96	3.05	2.95	3.01	3.10	3.20	3.06	3.13	3.22	3.32	3.16	3.23	3.33	3.43	
Amps	8.2	8.3	8.5	8.7	8.6	8.8	9.0	9.2	9.2	9.3	9.6	9.8	9.6	9.8	10.1	10.3	10.1	10.3	10.5	10.9	10.6	10.8	11.0	11.4	
Hi PR	152	163	173	180	170	183	194	202	194	209	220	230	221	238	251	262	248	267	282	294	274	295	312	325	
Lo PR	65	69	75	80	68	73	79	85	71	76	83	88	75	79	87	92	78	83	91	97	81	86	94	100	

Shaded area reflects ARI conditions IDB: Entering Indoor Dry Bulb Temperature kW = Total system power Amps = outdoor unit amps (comp.+fan)
 High and low pressures are measured at the liquid and suction service valves.

EXPANDED COOLING DATA — GPC1348M23A

IDB	Airflow	Outdoor Ambient Temperature																							
		65°F				75°F				85°F				95°F				105°F				115°F			
		59	63	67	71	59	63	67	71	59	63	67	71	59	63	67	71	59	63	67	71	59	63	67	71
1969	MBh	46.1	47.7	52.3	-	45.0	46.6	51.1	-	43.9	45.5	49.9	-	42.8	44.4	48.7	-	40.7	42.2	46.2	-	37.7	39.1	42.8	-
	S/T	0.77	0.65	0.45	-	0.80	0.67	0.46	-	0.82	0.69	0.48	-	0.85	0.71	0.49	-	0.88	0.74	0.51	-	0.89	0.74	0.51	-
	ΔT	17	14	11	-	17	15	11	-	17	15	11	-	17	15	11	-	17	14	11	-	16	14	10	-
	kW	3.37	3.43	3.53	-	3.60	3.67	3.78	-	3.81	3.89	4.00	-	3.99	4.07	4.20	-	4.15	4.23	4.36	-	4.28	4.37	4.50	-
	Amps	13.1	13.3	13.6	-	13.8	14.0	14.3	-	14.6	14.8	15.2	-	15.3	15.5	15.9	-	16.0	16.2	16.6	-	16.6	16.9	17.3	-
	Hi PR	154	166	175	-	173	186	196	-	197	212	223	-	224	241	254	-	252	271	286	-	278	299	316	-
	Lo PR	63	67	73	-	66	71	77	-	69	73	80	-	72	77	84	-	76	81	88	-	79	84	91	-
	MBh	44.7	46.3	50.8	-	43.7	45.3	49.6	-	42.6	44.2	48.4	-	41.6	43.1	47.2	-	39.5	41.0	44.9	-	36.6	37.9	41.6	-
	S/T	0.74	0.62	0.43	-	0.76	0.64	0.44	-	0.78	0.65	0.45	-	0.81	0.68	0.47	-	0.84	0.70	0.49	-	0.85	0.71	0.49	-
	ΔT	17	15	11	-	18	15	12	-	18	15	12	-	18	15	12	-	17	15	11	-	16	14	11	-
70	kW	3.34	3.41	3.51	-	3.58	3.65	3.75	-	3.78	3.86	3.97	-	3.96	4.04	4.16	-	4.12	4.20	4.33	-	4.25	4.34	4.47	-
	Amps	13.1	13.3	13.5	-	13.7	13.9	14.2	-	14.5	14.7	15.1	-	15.2	15.4	15.8	-	15.9	16.1	16.5	-	16.5	16.8	17.2	-
	Hi PR	152	164	173	-	171	184	194	-	195	209	221	-	222	239	252	-	249	268	283	-	275	296	313	-
	Lo PR	62	66	72	-	66	70	76	-	68	73	79	-	72	76	83	-	75	80	87	-	78	83	90	-
	MBh	41.3	42.8	46.9	-	40.3	41.8	45.8	-	39.4	40.8	44.7	-	38.4	39.8	43.6	-	36.5	37.8	41.4	-	33.8	35.0	38.4	-
	S/T	0.71	0.59	0.41	-	0.74	0.62	0.43	-	0.76	0.63	0.44	-	0.78	0.65	0.45	-	0.81	0.68	0.47	-	0.82	0.68	0.47	-
	ΔT	18	15	12	-	18	15	12	-	18	15	12	-	18	16	12	-	18	15	12	-	17	14	11	-
	kW	3.27	3.33	3.43	-	3.50	3.57	3.67	-	3.70	3.77	3.88	-	3.87	3.95	4.07	-	4.02	4.10	4.23	-	4.15	4.23	4.36	-
	Amps	12.8	13.0	13.3	-	13.5	13.7	14.0	-	14.2	14.5	14.8	-	14.9	15.1	15.5	-	15.5	15.8	16.2	-	16.2	16.5	16.9	-
	Hi PR	148	159	168	-	166	179	189	-	189	203	214	-	215	231	244	-	242	260	275	-	267	288	304	-
Lo PR	60	64	70	-	64	68	74	-	66	70	77	-	70	74	81	-	73	78	85	-	75	80	88	-	

1969	MBh	46.8	48.2	52.2	56.0	45.7	47.1	51.0	54.7	44.7	46.0	49.8	53.4	43.6	44.9	48.6	52.1	41.4	42.6	46.1	49.5	38.3	39.5	42.7	45.9
	S/T	0.88	0.79	0.60	0.38	0.91	0.81	0.62	0.40	0.93	0.84	0.63	0.41	0.96	0.86	0.65	0.42	1.00	0.90	0.68	0.44	1.00	0.90	0.68	0.44
	ΔT	19	18	15	10	19	18	15	10	19	18	15	10	20	18	15	10	19	18	15	10	18	17	14	9
	kW	3.39	3.46	3.56	3.66	3.63	3.70	3.81	3.92	3.84	3.92	4.03	4.16	4.02	4.11	4.23	4.36	4.18	4.27	4.40	4.53	4.31	4.40	4.54	4.68
	Amps	13.2	13.4	13.7	14.0	13.9	14.1	14.4	14.8	14.7	14.9	15.3	15.7	15.4	15.6	16.0	16.4	16.1	16.3	16.7	17.2	16.7	17.0	17.4	17.9
	Hi PR	156	167	177	184	175	188	198	207	199	214	226	235	226	243	257	268	254	274	289	302	281	302	319	333
	Lo PR	63	67	74	78	67	71	78	83	70	74	81	86	73	78	85	91	77	82	89	95	79	84	92	98
	MBh	45.5	46.8	50.7	54.4	44.4	45.7	49.5	53.1	43.4	44.6	48.3	51.9	42.3	43.6	47.1	50.6	40.2	41.4	44.8	48.1	37.2	38.3	41.5	44.5
	S/T	0.84	0.75	0.57	0.37	0.87	0.78	0.59	0.38	0.89	0.80	0.60	0.39	0.92	0.82	0.62	0.40	0.95	0.85	0.65	0.42	0.96	0.86	0.65	0.42
	ΔT	20	18	15	10	20	19	15	11	20	19	15	11	20	19	15	11	20	19	15	10	19	17	14	10
75	kW	3.37	3.43	3.53	3.63	3.60	3.67	3.78	3.89	3.81	3.89	4.00	4.12	3.99	4.07	4.20	4.33	4.15	4.23	4.36	4.50	4.28	4.37	4.51	4.65
	Amps	13.1	13.3	13.6	13.9	13.8	14.0	14.3	14.7	14.6	14.8	15.2	15.6	15.3	15.5	15.9	16.3	16.0	16.2	16.6	17.1	16.6	16.9	17.3	17.8
	Hi PR	154	166	175	183	173	186	196	205	197	212	223	233	224	241	254	265	252	271	286	299	278	299	316	330
	Lo PR	63	67	73	78	66	71	77	82	69	73	80	85	72	77	84	90	76	81	88	94	79	84	91	97
	MBh	42.0	43.2	46.8	50.2	41.0	42.2	45.7	49.0	40.0	41.2	44.6	47.9	39.0	40.2	43.5	46.7	37.1	38.2	41.3	44.4	34.4	35.4	38.3	41.1
	S/T	0.81	0.72	0.55	0.35	0.84	0.75	0.57	0.36	0.86	0.77	0.58	0.37	0.89	0.79	0.60	0.39	0.92	0.82	0.62	0.40	0.93	0.83	0.63	0.40
	ΔT	20	19	15	11	21	19	16	11	21	19	16	11	21	19	16	11	20	19	15	11	19	18	14	10
	kW	3.30	3.36	3.45	3.55	3.52	3.59	3.70	3.81	3.72	3.80	3.91	4.03	3.90	3.98	4.10	4.23	4.05	4.13	4.26	4.39	4.18	4.27	4.40	4.54
	Amps	12.9	13.1	13.4	13.7	13.6	13.8	14.1	14.4	14.3	14.6	14.9	15.3	15.0	15.2	15.6	16.0	15.6	15.9	16.3	16.7	16.3	16.6	17.0	17.4
	Hi PR	149	161	170	177	168	180	191	199	191	205	217	226	217	234	247	257	244	263	278	290	270	291	307	320
Lo PR	61	65	71	75	64	68	75	80	67	71	78	83	70	75	82	87	74	78	86	91	76	81	88	94	

Shaded area reflects ACCA (TVA) conditions IDB: Entering Indoor Dry Bulb Temperature kW = Total system power Amps = outdoor unit amps (comp. +fan)
 High and low pressures are measured at the liquid and suction service valves.

EXPANDED COOLING DATA — GPC1348M23A (CONT.)

IDB	Airflow	Outdoor Ambient Temperature												115°F											
		65°F				75°F				85°F					95°F				105°F						
		59	63	67	71	59	63	67	71	59	63	67	71		59	63	67	71	59	63	67	71			
1969	MBh	47.7	48.7	52.0	55.6	46.6	47.6	50.8	54.3	45.5	46.4	49.6	53.0	44.3	45.3	48.4	51.8	42.1	43.0	46.0	49.2	39.0	39.9	42.6	45.5
	S/T	0.96	0.90	0.74	0.55	1.00	0.94	0.76	0.57	1.00	0.96	0.78	0.58	1.00	1.00	0.81	0.60	1.00	1.00	0.84	0.63	1.00	1.00	0.84	0.63
	ΔT	21	21	18	14	22	21	18	14	21	21	18	14	21	21	18	15	20	20	18	14	18	19	17	13
	kW	3.42	3.48	3.58	3.69	3.66	3.73	3.84	3.95	3.87	3.95	4.06	4.19	4.05	4.14	4.26	4.40	4.21	4.30	4.43	4.57	4.35	4.44	4.58	4.72
	Amps	13.3	13.5	13.8	14.1	14.0	14.2	14.5	14.9	14.8	15.0	15.4	15.8	15.5	15.7	16.1	16.5	16.2	16.4	16.8	17.3	16.8	17.1	17.6	18.1
	Hi PR	157	169	179	186	176	190	200	209	201	216	228	238	228	246	260	271	257	277	292	305	284	306	323	337
	Lo PR	64	68	74	79	68	72	79	84	70	75	82	87	74	79	86	91	77	82	90	96	80	85	93	99
	MBh	46.3	47.3	50.5	54.0	45.2	46.2	49.4	52.8	44.1	45.1	48.2	51.5	43.1	44.0	47.0	50.2	40.9	41.8	44.7	47.7	37.9	38.7	41.4	44.2
	S/T	0.92	0.86	0.70	0.52	0.95	0.89	0.73	0.54	0.98	0.92	0.75	0.56	1.00	0.95	0.77	0.58	1.00	0.98	0.80	0.60	1.00	0.99	0.81	0.60
	ΔT	22	21	19	15	23	22	19	15	23	22	19	15	23	22	19	15	21	22	19	15	20	20	18	14
kW	3.39	3.46	3.56	3.66	3.63	3.70	3.81	3.92	3.84	3.92	4.03	4.16	4.02	4.11	4.23	4.36	4.18	4.27	4.40	4.54	4.32	4.41	4.54	4.69	
Amps	13.2	13.4	13.7	14.0	13.9	14.1	14.4	14.8	14.7	14.9	15.3	15.7	15.4	15.6	16.0	16.4	16.1	16.3	16.7	17.2	16.7	17.0	17.4	17.9	
Hi PR	156	167	177	184	175	188	198	207	199	214	226	235	226	243	257	268	254	274	289	302	281	303	319	333	
Lo PR	63	68	74	78	67	71	78	83	70	74	81	86	73	78	85	91	77	82	89	95	79	84	92	98	
MBh	42.7	43.6	46.6	49.9	41.7	42.6	45.6	48.7	40.7	41.6	44.5	47.5	39.7	40.6	43.4	46.4	37.8	38.6	41.2	44.1	35.0	35.7	38.2	40.8	
S/T	0.89	0.83	0.68	0.51	0.92	0.86	0.70	0.52	0.94	0.88	0.72	0.54	0.97	0.91	0.74	0.55	1.01	0.95	0.77	0.58	1.02	0.95	0.78	0.58	
ΔT	23	22	19	15	23	22	19	15	23	22	19	15	23	22	19	15	23	22	19	15	21	20	18	14	
kW	3.32	3.38	3.48	3.58	3.55	3.62	3.72	3.84	3.75	3.83	3.94	4.06	3.93	4.01	4.13	4.26	4.08	4.17	4.29	4.43	4.21	4.30	4.43	4.57	
Amps	13.0	13.2	13.5	13.8	13.6	13.9	14.2	14.5	14.4	14.6	15.0	15.4	15.1	15.3	15.7	16.1	15.7	16.0	16.4	16.8	16.4	16.7	17.1	17.6	
Hi PR	151	162	172	179	169	182	192	201	193	207	219	228	219	236	249	260	247	266	280	293	273	293	310	323	
Lo PR	62	65	71	76	65	69	76	80	68	72	78	84	71	76	82	88	74	79	86	92	77	82	89	95	
MBh	48.5	49.4	51.8	55.2	47.4	48.3	50.6	54.0	46.2	47.1	49.4	52.7	45.1	46.0	48.2	51.4	42.9	43.7	45.8	48.8	39.7	40.5	42.4	45.2	
S/T	1.00	0.98	0.88	0.71	1.00	1.00	0.91	0.74	1.00	1.00	0.94	0.76	1.00	1.00	0.97	0.78	1.00	1.00	0.81	0.81	1.00	1.00	0.81	0.82	
ΔT	23	23	21	18	22	23	22	19	22	22	22	19	21	21	22	19	20	20	21	19	19	19	20	17	
kW	3.44	3.51	3.61	3.72	3.68	3.76	3.87	3.98	3.90	3.98	4.10	4.22	4.09	4.17	4.30	4.43	4.25	4.33	4.47	4.61	4.38	4.47	4.61	4.76	
Amps	13.4	13.6	13.9	14.2	14.1	14.3	14.6	15.0	14.9	15.1	15.5	15.9	15.6	15.8	16.2	16.6	16.3	16.6	17.0	17.4	17.0	17.3	17.7	18.2	
Hi PR	159	171	180	188	178	192	202	211	203	218	230	240	231	248	262	273	260	279	295	308	287	309	326	340	
Lo PR	65	69	75	80	68	73	79	85	71	76	83	88	75	79	87	92	78	83	91	97	81	86	94	100	
MBh	47.1	48.0	50.3	53.6	46.0	46.9	49.1	52.4	44.9	45.8	47.9	51.1	43.8	44.7	46.8	49.9	41.6	42.4	44.4	47.4	38.5	39.3	41.2	43.9	
S/T	0.96	0.93	0.84	0.68	1.00	0.96	0.87	0.71	1.00	0.99	0.89	0.72	1.00	1.00	0.92	0.75	1.00	1.00	0.96	0.78	1.00	1.00	0.96	0.78	
ΔT	24	23	22	19	24	24	22	19	24	24	22	19	23	23	23	20	22	22	22	19	20	21	21	18	
kW	3.42	3.48	3.58	3.69	3.66	3.73	3.84	3.95	3.87	3.95	4.06	4.19	4.05	4.14	4.26	4.40	4.21	4.30	4.43	4.57	4.35	4.44	4.58	4.72	
Amps	13.3	13.5	13.8	14.1	14.0	14.2	14.5	14.9	14.8	15.0	15.4	15.8	15.5	15.7	16.1	16.5	16.2	16.4	16.8	17.3	16.8	17.1	17.6	18.1	
Hi PR	157	169	179	186	176	190	200	209	201	216	228	238	228	246	260	271	257	277	292	305	284	306	323	337	
Lo PR	64	68	74	79	68	72	79	84	70	75	82	87	74	79	86	91	77	82	90	96	80	85	93	99	
MBh	43.5	44.3	46.4	49.5	42.5	43.3	45.3	48.4	41.4	42.2	44.2	47.2	40.4	41.2	43.2	46.0	38.4	39.2	41.0	43.7	35.6	36.3	38.0	40.5	
S/T	0.93	0.90	0.81	0.66	0.96	0.93	0.84	0.68	0.99	0.95	0.86	0.70	1.00	0.98	0.89	0.72	1.00	1.00	0.92	0.75	1.00	1.00	0.93	0.75	
ΔT	24	24	23	20	25	24	23	20	25	24	23	20	24	24	23	20	23	24	23	20	21	22	21	18	
kW	3.34	3.41	3.50	3.61	3.58	3.65	3.75	3.86	3.78	3.86	3.97	4.09	3.96	4.04	4.16	4.29	4.11	4.20	4.33	4.46	4.25	4.33	4.47	4.61	
Amps	13.1	13.3	13.5	13.9	13.7	13.9	14.2	14.6	14.5	14.7	15.1	15.5	15.2	15.4	15.8	16.2	15.8	16.1	16.5	17.0	16.5	16.8	17.2	17.7	
Hi PR	152	164	173	181	171	184	194	203	195	209	221	231	222	238	252	263	249	268	283	295	275	296	313	326	
Lo PR	62	66	72	77	66	70	76	81	68	73	79	84	72	76	83	89	75	80	87	93	78	83	90	96	

Shaded area reflects ARI conditions IDB: Entering Indoor Dry Bulb Temperature kW = Total system power Amps = outdoor unit amps (comp.+fan)
 High and low pressures are measured at the liquid and suction service valves.

EXPANDED COOLING DATA — GPC1360M23A

IDB	Airflow	Outdoor Ambient Temperature																							
		65°F				75°F				85°F				95°F				105°F				115°F			
		59	63	67	71	59	63	67	71	59	63	67	71	59	63	67	71	59	63	67	71	59	63	67	71
2138	MBh	55.4	57.4	62.9	-	54.1	56.1	61.4	-	52.8	54.7	59.9	-	51.5	53.4	58.5	-	48.9	50.7	55.6	-	45.3	47.0	51.5	-
	S/T	0.74	0.62	0.43	-	0.77	0.64	0.45	-	0.79	0.66	0.46	-	0.82	0.68	0.47	-	0.85	0.71	0.49	-	0.85	0.71	0.49	-
	ΔT	18	15	12	-	18	16	12	-	18	16	12	-	18	16	12	-	18	15	12	-	17	14	11	-
	kW	4.06	4.14	4.28	-	4.38	4.47	4.62	-	4.66	4.76	4.92	-	4.91	5.02	5.19	-	5.12	5.23	5.41	-	5.30	5.42	5.61	-
	Amps	15.8	16.0	16.4	-	16.6	16.9	17.3	-	17.6	17.9	18.3	-	18.4	18.7	19.2	-	19.2	19.6	20.1	-	20.1	20.4	20.9	-
	Hi PR	166	179	189	-	186	200	212	-	212	228	241	-	241	260	274	-	271	292	308	-	300	323	341	-
	Lo PR	62	66	73	-	66	70	77	-	69	73	80	-	72	77	84	-	75	80	88	-	78	83	91	-
	MBh	53.8	55.7	61.0	-	52.5	54.4	59.6	-	51.3	53.1	58.2	-	50.0	51.8	56.8	-	47.5	49.2	53.9	-	44.0	45.6	50.0	-
	S/T	0.71	0.59	0.41	-	0.73	0.61	0.43	-	0.75	0.63	0.44	-	0.78	0.65	0.45	-	0.81	0.67	0.47	-	0.81	0.68	0.47	-
	ΔT	18	16	12	-	19	16	12	-	19	16	12	-	19	16	12	-	19	16	12	-	17	15	11	-
70	kW	4.02	4.11	4.24	-	4.34	4.44	4.58	-	4.62	4.72	4.88	-	4.87	4.98	5.14	-	5.07	5.19	5.37	-	5.26	5.38	5.56	-
	Amps	15.7	15.9	16.3	-	16.5	16.8	17.2	-	17.5	17.8	18.2	-	18.3	18.6	19.0	-	19.1	19.5	19.9	-	19.9	20.3	20.8	-
	Hi PR	164	177	187	-	184	198	210	-	210	226	238	-	239	257	271	-	269	289	305	-	297	320	337	-
	Lo PR	62	66	72	-	65	69	76	-	68	72	79	-	71	76	83	-	75	79	87	-	77	82	90	-
	MBh	49.6	51.4	56.3	-	48.5	50.2	55.0	-	47.3	49.0	53.7	-	46.2	47.8	52.4	-	43.8	45.4	49.8	-	40.6	42.1	46.1	-
	S/T	0.68	0.57	0.40	-	0.71	0.59	0.41	-	0.73	0.61	0.42	-	0.75	0.63	0.43	-	0.78	0.65	0.45	-	0.78	0.66	0.45	-
	ΔT	19	16	12	-	19	16	12	-	19	16	12	-	19	17	13	-	19	16	12	-	18	15	12	-
	kW	3.93	4.01	4.14	-	4.23	4.33	4.47	-	4.50	4.60	4.76	-	4.74	4.85	5.01	-	4.95	5.06	5.23	-	5.12	5.24	5.41	-
	Amps	15.4	15.7	16.0	-	16.2	16.5	16.8	-	17.1	17.4	17.8	-	17.9	18.2	18.7	-	18.7	19.1	19.5	-	19.5	19.9	20.4	-
	Hi PR	159	172	181	-	179	193	203	-	203	219	231	-	232	249	263	-	261	281	296	-	288	310	327	-
Lo PR	60	64	70	-	63	67	74	-	66	70	76	-	69	74	80	-	72	77	84	-	75	80	87	-	

2138	MBh	56.3	58.0	62.7	67.3	55.0	56.6	61.3	65.8	53.7	55.3	59.8	64.2	52.4	53.9	58.4	62.6	49.8	51.2	55.5	59.5	46.1	47.5	51.4	55.1
	S/T	0.84	0.76	0.57	0.37	0.88	0.78	0.59	0.38	0.90	0.80	0.61	0.39	0.93	0.83	0.63	0.40	0.96	0.86	0.65	0.42	0.97	0.87	0.66	0.42
	ΔT	20	19	15	11	21	19	16	11	21	19	16	11	21	19	16	11	21	19	16	11	19	18	15	10
	kW	4.09	4.18	4.31	4.46	4.41	4.51	4.66	4.81	4.70	4.80	4.96	5.13	4.95	5.06	5.23	5.41	5.16	5.28	5.46	5.65	5.35	5.47	5.66	5.85
	Amps	15.9	16.1	16.5	16.9	16.7	17.0	17.4	17.8	17.7	18.0	18.4	18.9	18.5	18.9	19.3	19.8	19.4	19.7	20.2	20.8	20.2	20.6	21.1	21.7
	Hi PR	168	180	191	199	188	202	214	223	214	230	243	254	244	262	277	289	274	295	312	325	303	326	344	359
	Lo PR	63	67	73	78	67	71	77	82	69	74	80	86	73	77	84	90	76	81	89	94	79	84	92	98
	MBh	54.7	56.3	60.9	65.4	53.4	55.0	59.5	63.9	52.1	53.7	58.1	62.3	50.9	52.4	56.7	60.8	48.3	49.7	53.8	57.8	44.7	46.1	49.9	53.5
	S/T	0.81	0.72	0.55	0.35	0.84	0.75	0.57	0.36	0.86	0.77	0.58	0.37	0.88	0.79	0.60	0.38	0.92	0.82	0.62	0.40	0.93	0.83	0.63	0.40
	ΔT	21	20	16	11	22	20	16	11	22	20	16	11	22	20	16	11	21	20	16	11	20	18	15	10
75	kW	4.06	4.15	4.28	4.42	4.38	4.47	4.62	4.77	4.66	4.76	4.92	5.09	4.91	5.02	5.19	5.36	5.12	5.24	5.41	5.60	5.30	5.42	5.61	5.80
	Amps	15.8	16.0	16.4	16.8	16.6	16.9	17.3	17.7	17.6	17.9	18.3	18.8	18.4	18.7	19.2	19.7	19.2	19.6	20.1	20.6	20.1	20.4	20.9	21.5
	Hi PR	166	179	189	197	186	200	212	221	212	228	241	251	241	260	274	286	271	292	309	322	300	323	341	356
	Lo PR	62	66	73	77	66	70	77	82	69	73	80	85	72	77	84	89	75	80	88	93	78	83	91	97
	MBh	50.5	51.9	56.2	60.3	49.3	50.7	54.9	58.9	48.1	49.5	53.6	57.5	46.9	48.3	52.3	56.1	44.6	45.9	49.7	53.3	41.3	42.5	46.0	49.4
	S/T	0.78	0.69	0.53	0.34	0.81	0.72	0.55	0.35	0.83	0.74	0.56	0.36	0.85	0.76	0.58	0.37	0.88	0.79	0.60	0.39	0.89	0.80	0.60	0.39
	ΔT	22	20	16	11	22	20	17	11	22	20	17	11	22	20	17	12	22	20	16	11	20	19	15	11
	kW	3.96	4.04	4.17	4.31	4.27	4.36	4.50	4.65	4.54	4.64	4.80	4.96	4.78	4.89	5.05	5.23	4.99	5.10	5.27	5.45	5.17	5.28	5.46	5.65
	Amps	15.5	15.8	16.1	16.5	16.3	16.6	16.9	17.4	17.3	17.5	17.9	18.4	18.1	18.4	18.8	19.3	18.9	19.2	19.7	20.2	19.7	20.0	20.5	21.1
	Hi PR	161	173	183	191	181	194	205	214	206	221	234	244	234	252	266	277	263	283	299	312	291	313	331	345
Lo PR	61	64	70	75	64	68	74	79	67	71	77	82	70	74	81	86	73	78	85	91	76	81	88	94	

Shaded area reflects ACCA (TVA) conditions IDB: Entering Indoor Dry Bulb Temperature kW = Total system power Amps = outdoor unit amps (comp.+fan)
 High and low pressures are measured at the liquid and suction service valves.

EXPANDED COOLING DATA — GPC1360M23A (CONT.)

IDB	Airflow	Outdoor Ambient Temperature																								
		65°F				75°F				85°F				95°F				105°F				115°F				
		59	63	67	71	59	63	67	71	59	63	67	71	59	63	67	71	59	63	67	71	59	63	67	71	
80	2138	MBh	57.3	58.6	62.6	66.9	56.0	57.2	61.1	65.3	54.6	55.8	59.6	63.8	53.3	54.5	58.2	62.2	50.6	51.7	55.3	59.1	46.9	47.9	51.2	54.7
		S/T	0.93	0.87	0.71	0.53	0.96	0.90	0.73	0.55	1.00	0.92	0.75	0.56	1.00	0.95	0.78	0.58	1.00	1.00	0.81	0.60	1.00	1.00	0.81	0.61
	ΔT	23	22	19	15	24	22	19	15	24	22	19	15	23	22	19	16	22	22	19	15	20	21	18	14	
	kW	4.12	4.21	4.35	4.49	4.45	4.55	4.70	4.86	4.74	4.84	5.00	5.17	4.99	5.10	5.28	5.46	5.21	5.33	5.51	5.70	5.39	5.52	5.70	5.90	
	Amps	16.0	16.2	16.6	17.0	16.8	17.1	17.5	17.9	17.8	18.1	18.5	19.0	18.7	19.0	19.4	20.0	19.5	19.8	20.3	20.9	20.3	20.7	21.2	21.8	
	Hi PR	169	182	192	201	190	205	216	225	216	233	246	256	246	265	280	292	277	298	315	328	306	329	348	363	
	Lo PR	64	68	74	79	67	72	78	83	70	74	81	87	73	78	85	91	77	82	89	95	80	85	93	99	
	MBh	55.6	56.9	60.7	64.9	54.3	55.5	59.3	63.4	53.0	54.2	57.9	61.9	51.8	52.9	56.5	60.4	49.2	50.2	53.7	57.4	45.5	46.5	49.7	53.2	
	S/T	0.88	0.83	0.67	0.50	0.92	0.86	0.70	0.52	0.94	0.88	0.72	0.54	0.97	0.91	0.74	0.55	1.00	0.94	0.77	0.57	1.00	0.95	0.77	0.58	
	ΔT	24	23	20	16	24	23	20	16	24	23	20	16	24	23	20	16	24	23	20	16	22	21	19	15	
kW	4.09	4.18	4.31	4.46	4.41	4.51	4.66	4.81	4.70	4.80	4.96	5.13	4.95	5.06	5.23	5.41	5.16	5.28	5.46	5.65	5.35	5.47	5.66	5.85		
Amps	15.9	16.1	16.5	16.9	16.7	17.0	17.4	17.8	17.7	18.0	18.4	18.9	18.5	18.9	19.3	19.8	19.4	19.7	20.2	20.8	20.2	20.6	21.1	21.7		
Hi PR	168	180	191	199	188	203	214	223	214	230	243	254	244	262	277	289	274	295	312	325	303	326	344	359		
Lo PR	63	67	73	78	67	71	77	82	69	74	80	86	73	77	85	90	76	81	89	94	79	84	92	98		
MBh	51.4	52.5	56.1	59.9	50.2	51.3	54.8	58.5	49.0	50.0	53.5	57.1	47.8	48.8	52.1	55.7	45.4	46.4	49.5	53.0	42.0	43.0	45.9	49.1		
S/T	0.85	0.80	0.65	0.49	0.88	0.83	0.67	0.50	0.91	0.85	0.69	0.52	0.93	0.88	0.71	0.53	0.97	0.91	0.74	0.55	0.98	0.92	0.75	0.56		
ΔT	24	23	20	16	24	23	20	16	24	23	20	16	25	24	21	16	24	23	20	16	23	22	19	15		
kW	3.99	4.08	4.21	4.35	4.30	4.40	4.54	4.69	4.58	4.68	4.84	5.00	4.82	4.93	5.10	5.27	5.03	5.14	5.32	5.50	5.21	5.33	5.51	5.70		
Amps	15.6	15.8	16.2	16.6	16.4	16.7	17.0	17.5	17.4	17.6	18.1	18.5	18.2	18.5	18.9	19.4	19.0	19.3	19.8	20.3	19.8	20.1	20.6	21.2		
Hi PR	163	175	185	193	183	196	207	216	208	223	236	246	236	254	269	280	266	286	302	315	294	316	334	348		
Lo PR	61	65	71	76	65	69	75	80	67	71	78	83	71	75	82	87	74	79	86	91	76	81	89	95		

85	2138	MBh	58.3	59.4	62.2	66.4	56.9	58.1	60.8	64.9	55.6	56.7	59.4	63.3	54.2	55.3	57.9	61.8	51.5	52.5	55.0	58.7	47.7	48.7	51.0	54.4
		S/T	0.97	0.94	0.85	0.69	1.00	0.97	0.88	0.71	1.00	1.00	0.90	0.73	1.00	1.00	0.93	0.75	1.00	1.00	0.96	0.78	1.00	1.00	0.97	0.79
	ΔT	24	24	23	20	24	24	23	20	24	24	23	20	23	24	23	20	22	23	23	20	21	21	21	18	
	kW	4.16	4.25	4.39	4.53	4.49	4.59	4.74	4.90	4.78	4.88	5.05	5.22	5.03	5.15	5.32	5.50	5.25	5.37	5.55	5.75	5.44	5.56	5.75	5.95	
	Amps	16.1	16.3	16.7	17.1	16.9	17.2	17.6	18.0	17.9	18.2	18.6	19.1	18.8	19.1	19.6	20.1	19.6	20.0	20.5	21.0	20.5	20.8	21.4	22.0	
	Hi PR	171	184	194	203	192	207	218	228	218	235	248	259	249	268	283	295	280	301	318	332	309	333	351	366	
	Lo PR	64	68	75	80	68	72	79	84	71	75	82	87	74	79	86	92	78	83	90	96	80	86	93	100	
	MBh	56.6	57.7	60.4	64.5	55.3	56.4	59.0	63.0	54.0	55.0	57.6	61.5	52.7	53.7	56.2	60.0	50.0	51.0	53.4	57.0	46.3	47.2	49.5	52.8	
	S/T	0.93	0.89	0.81	0.65	0.96	0.93	0.84	0.68	0.98	0.95	0.86	0.70	1.00	0.98	0.89	0.72	1.00	1.00	0.92	0.75	1.00	1.00	0.93	0.75	
	ΔT	25	25	24	20	26	25	24	21	26	25	24	21	25	25	24	21	24	25	24	21	22	23	22	19	
kW	4.12	4.21	4.35	4.49	4.45	4.55	4.70	4.86	4.74	4.84	5.00	5.17	4.99	5.10	5.28	5.46	5.21	5.33	5.51	5.70	5.39	5.52	5.70	5.90		
Amps	16.0	16.2	16.6	17.0	16.8	17.1	17.5	17.9	17.8	18.1	18.5	19.0	18.7	19.0	19.4	20.0	19.5	19.8	20.3	20.9	20.3	20.7	21.2	21.8		
Hi PR	169	182	192	201	190	205	216	225	216	233	246	256	246	265	280	292	277	298	315	328	306	329	348	363		
Lo PR	64	68	74	79	67	72	78	83	70	74	81	87	73	78	85	91	77	82	89	95	80	85	93	99		
MBh	52.2	53.3	55.8	59.5	51.0	52.0	54.5	58.1	49.8	50.8	53.2	56.7	48.6	49.5	51.9	55.4	46.2	47.1	49.3	52.6	42.8	43.6	45.7	48.7		
S/T	0.89	0.86	0.78	0.63	0.93	0.89	0.81	0.65	0.95	0.92	0.83	0.67	0.98	0.95	0.85	0.69	1.00	0.98	0.89	0.72	1.00	0.99	0.89	0.72		
ΔT	26	25	24	21	26	26	24	21	26	26	24	21	26	26	24	21	26	26	24	21	26	24	23	20		
kW	4.02	4.11	4.24	4.38	4.34	4.43	4.58	4.73	4.62	4.72	4.88	5.04	4.86	4.97	5.14	5.32	5.07	5.19	5.36	5.55	5.25	5.37	5.56	5.75		
Amps	15.7	15.9	16.3	16.7	16.5	16.8	17.2	17.6	17.5	17.8	18.2	18.6	18.3	18.6	19.0	19.6	19.1	19.4	19.9	20.5	19.9	20.3	20.8	21.4		
Hi PR	164	177	187	195	184	198	210	219	210	226	238	249	239	257	271	283	269	289	305	318	297	319	337	352		
Lo PR	62	66	72	76	65	69	76	81	68	72	79	84	71	76	83	88	75	79	87	92	77	82	90	96		

Shaded area reflects ARI conditions IDB: Entering Indoor Dry Bulb Temperature kW = Total system power Amps = outdoor unit amps (comp. +fan)
 High and low pressures are measured at the liquid and suction service valves.

WIRING DIAGRAM — GPC1336M23*

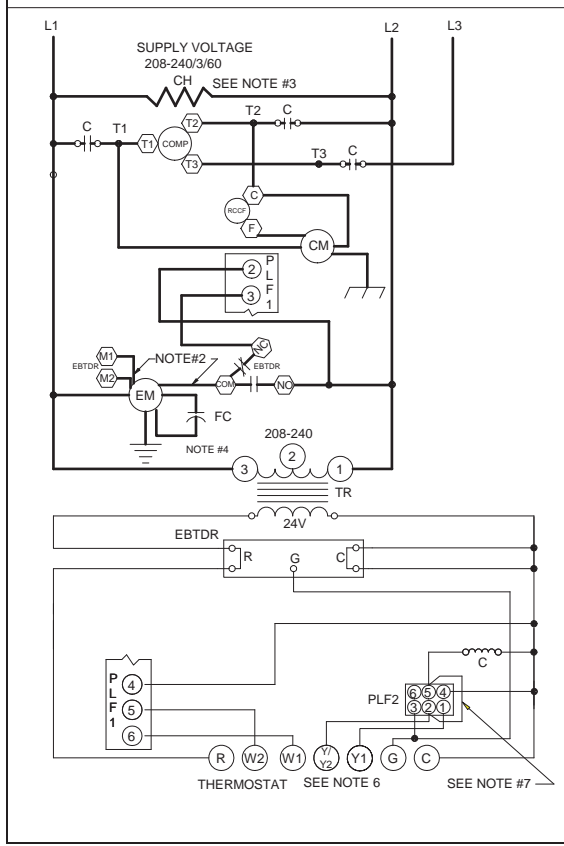
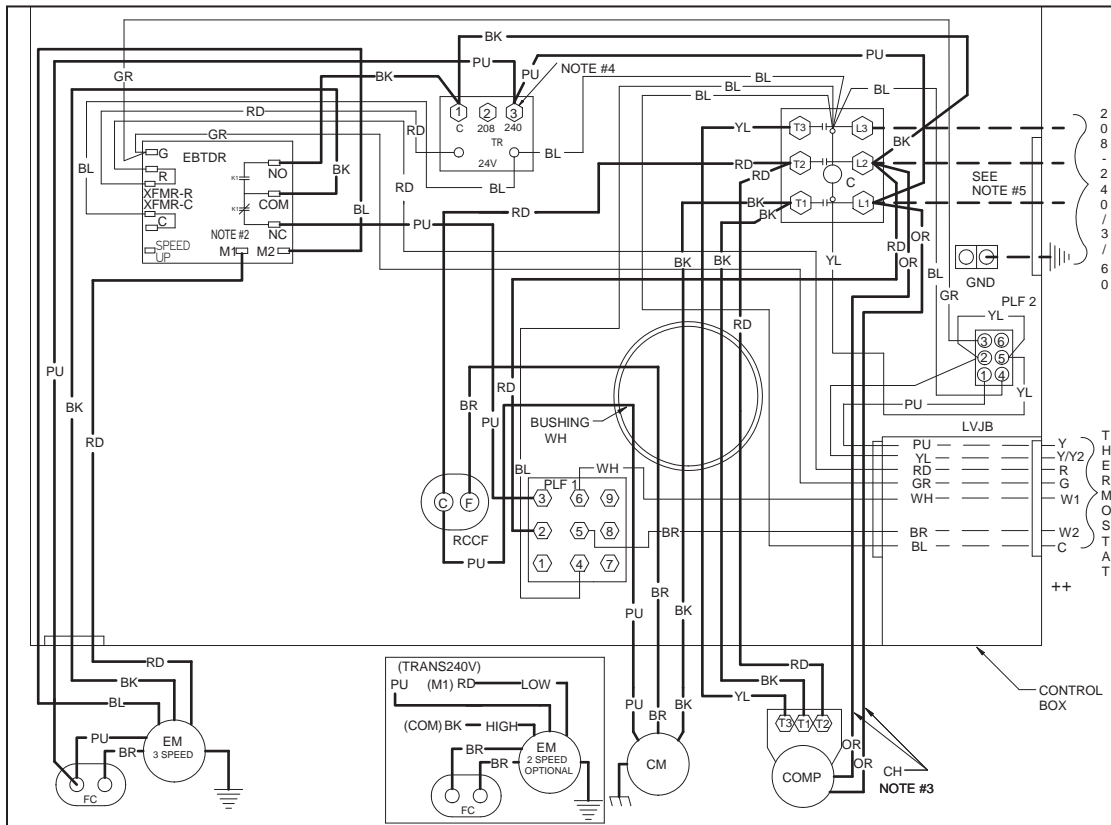

COMPONENT LEGEND

C	CONTACTOR	CH	CRANKCASE HEATER
CM	CONDENSER MOTOR	COMP	COMPRESSOR
ECON	ECONOMIZER	EBTD	ELECTRONIC BLOWER TIME DELAY
R	RELAY	EM	EVAPORATOR MOTOR
FC	FAN CAPACITOR	GND	EQUIPMENT GROUND
LVJB	LOW VOLTAGE JUNCTION BOX	PLF	FEMALE PLUG / CONNECTOR
RCCF	RUN CAPACITOR FOR COMPRESSOR AND FAN	TR	TRANSFORMER

FACTORY WIRING

- LINE VOLTAGE
- - - LOW VOLTAGE
- OPTIMAL HIGH VOLTAGE
- - - VOLTAGE

FIELD WIRING

- HIGH VOLTAGE
- - - LOW VOLTAGE

WIRE CODE

- BK BLACK
- BL BLUE
- BR BROWN
- GR GREEN
- OR ORANGE
- PU PURPLE
- RD RED
- WH WHITE
- YL YELLOW

NOTES:

- REPLACEMENT WIRE MUST BE SAME SIZE AND TYPE INSULATION AS ORIGINAL (AT LEAST 105°C) USE COPPER CONDUCTOR ONLY.
- TO CHANGE EVAPORATOR MOTOR SPEED REPLACE LEAD ON EBTD "COM" WITH LEAD ON EBTD "M1" OR "M2"
- CRANKCASE HEAT NOT SUPPLIED ON ALL UNITS.
- FOR 208 VOLT TRANSFORMER OPERATION MOVE PURPLE WIRES FROM TERMINAL 3 TERMINAL 2 ON TRANSFORMER.
- USE COPPER CONDUCTORS ONLY
- USE N.E.C. CLASS 2 WIRE
- WITH ECONOMIZER OPTION USE PURPLE WIRE FOR Y1 AND YELLOW WIRE FOR Y2. WITHOUT ECONOMIZER OPTION USE YELLOW WIRE FOR Y.
- ECONOMIZER PLUG LOCATED IN THE RETURN AIR COMPARTMENT, REMOVE MALE PLUG, ATTACH FEMALE PLUG TO THE ECONOMIZER ACCESSORY.

SEE UNIT RATING PLATE FOR TYPE AND SIZE OF OVER CURRENT PROTECTION

208-240/3/60 0140G00513 REV. B

High Voltage: Disconnect all power before servicing or installing this unit. Multiple power sources may be present. Failure to do so may cause property damage, personal injury, or death.

WARNING

Wiring is subject to change. Always refer to the wiring diagram on the unit for the most up-to-date schematic.

WIRING DIAGRAM — GPC1348-60M23*

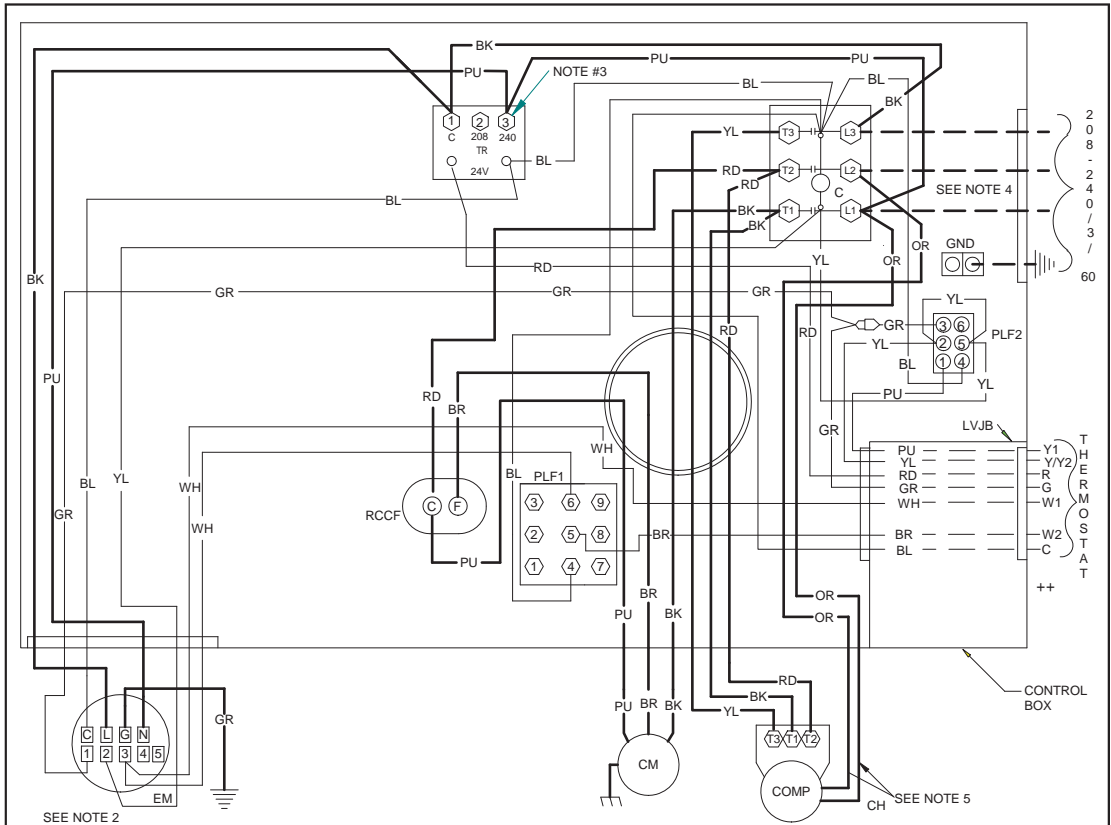

High Voltage: Disconnect all power before servicing or installing this unit. Multiple power sources may be present. Failure to do so may cause property damage, personal injury, or death.

WARNING

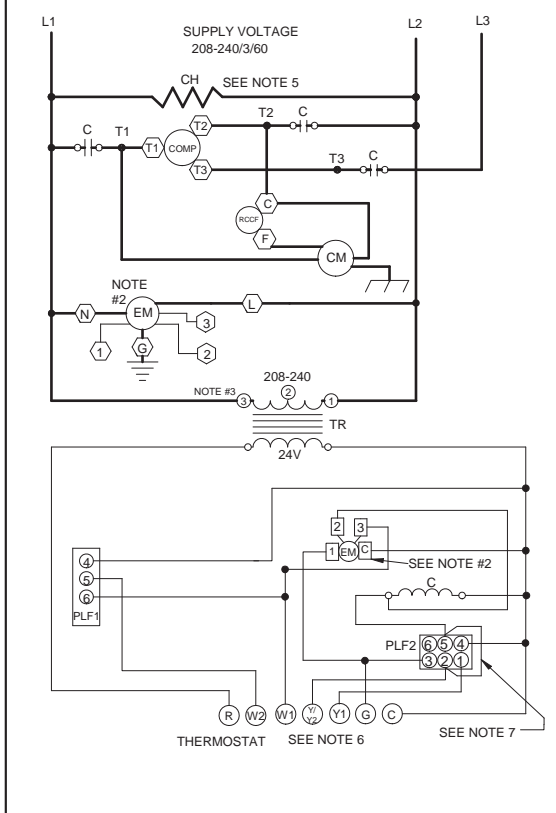

COMPONENT LEGEND

C	CONTACTOR	FACTORY WIRING	— LINE VOLTAGE
CH	CRANKCASE HEATER	— LOW VOLTAGE	— OPTIMAL HIGH VOLTAGE
CM	CONDENSER MOTOR	— VOLTAGE	
COMP	COMPRESSOR		
ECON	ECONOMIZER	FIELD WIRING	— HIGH VOLTAGE
EM	EVAPORATOR MOTOR	— LOW VOLTAGE	
GND	EQUIPMENT GROUND		
LVJB	LOW VOLTAGE JUNCTION BOX		
PLF	FEMALE PLUG / CONNECTOR		
RCCF	RUN CAPACITOR FOR COMPRESSOR AND FAN		
TR	TRANSFORMER		

WIRE CODE

BK	BLACK
BL	BLUE
BR	BROWN
GR	GREEN
OR	ORANGE
PU	PURPLE
RD	RED
WH	WHITE
YL	YELLOW

NOTES:

- REPLACEMENT WIRE MUST BE SAME SIZE AND TYPE INSULATION AS ORIGINAL (AT LEAST 105°C) USE COPPER CONDUCTOR ONLY.
- TO CHANGE EVAPORATOR MOTOR SPEED MOVE WHITE AND YELLOW LEADS FROM EM"2" AND "3" TO "4" AND "5". IF BOTH LEADS ARE ENERGIZED, THE HIGHER SPEED SETTING IS USED.
- FOR 208 VOLT TRANSFORMER OPERATION MOVE PURPLE WIRES FROM TERMINAL 3 TO TERMINAL 2 ON TRANSFORMER.
- USE COPPER CONDUCTORS ONLY
- ++ USE N.E.C. CLASS 2 WIRE
- CRANKCASE HEAT NOT SUPPLIED ON ALL UNITS.
- WITH ECONOMIZER OPTION USE PURPLE WIRE FOR Y1 AND YELLOW WIRE FOR Y2. WITHOUT ECONOMIZER OPTION USE YELLOW WIRE FOR Y.
- ECONOMIZER PLUG LOCATED IN THE RETURN AIR COMPARTMENT, REMOVE MALE PLUG, ATTACH FEMALE PLUG TO ECONOMIZER ACCESSORY.

SEE UNIT RATING PLATE FOR TYPE AND SIZE OF OVER CURRENT PROTECTION

208-240/3/60 0140G00514 REV A

Wiring is subject to change. Always refer to the wiring diagram on the unit for the most up-to-date schematic.

ACCESSORIES

Item	Description
GPH13MED102/103*	Downflow Economizer for GPC13M/ GPH13M Packaged Units
GPH13MFR102/103*	Internal filter rack for Downflow Applications
OT18-60A	Outdoor Thermostat Kit with Lockout Stat
OT/EHR18-60	Emergency Heat Relay kit
PGC101/102/103*	Roof Curb for GPC13M-/GPH13M- Electric/ Electric Packaged Unit
PGMDD101/102*	Manual Damper for Downflow Application — Medium Chassis
PGMDMD101/102*	Motorized Damper for Downflow Application — Medium Chassis
PGMDD103*	Manual Damper for Downflow Application — Large Chassis
PGMDMD103*	Motorized Damper for Downflow Application — Large Chassis
PGMDH102*	Manual 25% Fresh Air Damper — Horizontal Applications
PGMDH103*	Manual 25% Fresh Air Damper — Horizontal Applications
PGMDMH102*	Motorized 25% Fresh Air Damper — Horizontal Applications
PGMDMH103*	Motorized 25% Fresh Air Damper — Horizontal Applications
PCFR101-103	External Horizontal Filter Rack
SQRPG101/102*	Square-to-Round Adapter with 16" Round — Downflow Applications
SQRPG103*	Square-to-Round Adapter with 18" Round — Downflow Applications
SQRPGH101/102*	Square-to-Round Adapters for GPC/ GPH Packaged Units 16"&14"
SQRPGH103*	Square-to-Round Adapters for GPC/ GPH Packaged Units 18"&14"

* Offered by McDaniel Metals • Main: (281) 987-8400 • Fax: (281) 987-9494

HEAT KIT SELECTION

HKR3-15B	Heat Kit for 3-, 4-, and 5-ton units*
HKR3-20B	Heat Kit for 4-, and 5-ton units*

* Revision level that may or may not be designated

Note: See SS-GHKR (HKR Spec Sheet) for further information about Heat Kits

PRODUCT SPECIFICATIONS

NOTES

